

Makita

CATÁLOGO ACCESORIOS 2018



2018-1

MAKITA LA EXTENSIÓN DE TUS MANOS

INDICE

Brocas metal- madera	22
Brocas concreto	47
Puntas	66
Set de brocas y puntas	91
Baterías, lámparas y cargadores	99
Hojas de sierra	107
Seguetas	115
Cardas	128
Discos abrasivos	134
Productos de lija y fibra	146
Multiherramientas	164
Discos de diamante	176
Fresas para router	189
Equipo para exterior	204
Bridas, tuercas y guías	212
Guardas, puños y recolectores de polvo	217
Mezcladores y boquillas	222
Guantes, lentes de seguridad y accesorios para aspiradoras	227
Juegos de servicio y carbones	232

ÍNDICE

0042010	31	953603040	208	6258060001	206	122402-1	162
6004	214	957250100	188	6258061001	206	122428-3	218
7165	229	957415030	188	6348001000	206	122446-1	214
7167	229	957415040	188	6348001001	206	1224473-8	193
7685	229	957415060	188	6348007001	206	122450-0	83
8003	213	957696056	188	6348008001	206	122470-4	215
139121	106	957696064	188	6357500000	208	122472-0	216
139129	106	980008102	210	6417014150	207	122473-8	193
1229314	206	980008103	210	6418027000	207	122474-6	162
1584766	208	980008104	210	6418500701	207	122512-4	230
1684085	208	980008112	210	6419038001	207	122520-5	230
1684506	208	980008118	210	6659501100	207	122536-0	215
1951490	206	980008121	210	6659504000	207	122540-9	215
1952496	207	980008123	210	6908031000	211	122548-3	162
1952527	207	980008124	210	6909035001	207	122555-6	214
1952828	207	980008211	209	6909039000	207	122556-4	214
1955656	211	980008213	209	6909093000	127	122562-9	162
7920873	111	980008217	209	6909500100	211	122567-9	215
170043110	206	980008265	210	6909511500	207	122571-8	215
2097055108	233	980008270	210	6919500000	211	122591-2	162
415038751	188	980008302	209	6919500500	207	122625-1	215
415045751	188	980008606	210	6939025000	211	122700-3	190
442035661	208	980008607	210	6939028000	211	122707-9	214
442040661	208	980008608	210	6949001000	211	122729-9	214
443035661	208	980008610	210	6958011000	211	122730-4	214
443045651	208	980008611	210	6958018000	211	122735-4	214
443053651	208	980008618	210	6958025000	211	122740-1	214
443053661	208	980308620	210	007430-0	149	122814-8	207
445045455	208	980508620	210	007431-0	149	122822-9	105
445050455	208	988000707	228	007432-0	149	122852-0	162
445050655	208	988000708	228	060000015N	127	122853-8	162
445060455	208	988000709	228	060000026N	127	122854-6	215
445060655	208	988000710	228	060040000N	127	122859-6	230
445070455	208	988000711	228	110702-A	225	122882-1	206
445074452	208	988000807	228	110706-A	225	122886-3	218
465043755	188	988000808	228	110720-A	225	122890-2	218
523093664	208	988000809	228	110730-A	225	122892-8	218
523093672	208	988000810	228	110731-A	226	122906-3	207
528092652	208	988000811	228	110742-A	226	122930-6	215
528099664	208	988000909	228	110746-A	225	122938-0	218
528099668	208	988000910	228	110751-A	225	122939-8	218
528099672	208	988000911	228	122193-4	162	123004-6	126
528099684	208	988002256	209	122212-6	83	123009-6	126
528099694	208	988002265	209	122213-4	83	123010-1	126
528099696	208	988002656	210	122230-4	162	123022-4	191
531492656	208	988002658	210	122256-6	190	123029-0	191
0717059990	127	988050211	209	122291-4	230	123030-5	125
0722104800	211	988070101	209	122296-4	162	123053-3	126
0722105000	207	988070819	209	122297-2	162	123055-9	126
940827000	127	988070824	209	122321-1	162	123058-3	192
941713001	207	5609004000	207	122329-5	162	123060-6	126
953003060	208	5929002000	207	122330-0	162	123062-2	126
953003070	208	6248002000	206	122339-2	162	123138-5	218
953003090	208	6249000000	127	122343-1	191	123200-6	214
953003100	208	6255008000	207	122351-2	162	123203-0	162
953004010	208	6258028002	206	122376-6	221	123241-2	207
953100090	208	6258053001	206	122387-1	188	125112-9	125

ÍNDICE

125267-0	218	164470-8	191	192978-2	221	194310-6	88
125354-5	125	164775-6	191	192987-1	192	194311-4	88
125802-4	207	164776-4	191	193012-0	192	194312-2	88
126187-1	207	164818-4	214	193073-1	191	194367-7	191
132025-7	230	164834-6	191	193103-8	193	194368-5	191
132276-260	124	164879-4	218	193104-6	193	194385-5	191
134152-6	188	165053-7	218	193143-6	192	194483-5	218
134182-7	230	165055-3	218	193155-9	193	194514-0	218
134887-9	219	165362-4	218	193214-9	192	194543-3	218
134890-0	219	165556-7	231	193215-7	192	194547-5	233
134909-5	219	166027-1	162	193235-1	191	194566-1	231
135107-4	218	166047-5	162	193243-2	233	194579-2	191
135108-2	218	166078-4	162	193244-0	233	194649-7	105
135197-7	218	166079-2	162	193261-0	191	194731-2	105
135209-6	218	166084-9	162	193262-8	191	194935-6	192
135245-2	218	166095-4	105	193263-6	191	194943-7	216
135269-8	219	168313-6	216	193264-4	191	194961-5	233
135332-7	219	168467-9	105	193265-2	191	194963-1	233
135398-7	206	181490-7	221	193266-0	191	194968-1	233
135629-4	218	181503-4	233	193281-4	233	194970-4	233
140115-2	162	182229-1	105	193283-0	233	194971-2	233
140440-1	160	185200-6	233	193326-8	231	194972-0	233
140583-9	105	191383-0	125	193366-6	191	194974-6	233
142603-5	208	191395-3	218	193379-7	193	194975-5	233
150662-5	214	191454-3	126	193390-9	233	194976-2	233
150796-4	214	191455-1	126	193391-7	233	194977-0	233
151449-8	231	191496-7	231	193392-5	233	194982-7	233
151517-7	162	191657-9	230	193393-3	233	194984-3	233
152456-4	162	191724-0	230	193396-7	233	194985-1	233
152483-1	83	191750-9	230	193402-8	233	194986-9	233
152491-2	218	191897-9	114	193448-4	192	194987-7	233
152492-0	218	191954-3	233	193472-7	105	194991-6	233
152521-9	219	192016-0	88	193520-2	89	194992-4	233
152539-0	218	192035-6	193	193606-2	233	194993-2	233
153489-2	218	192077-0	89	193681-8	105	194996-6	233
153503-4	219	192118-2	214	193689-2	105	194997-4	233
153504-2	218	192236-6	230	193691-5	88	195001-2	233
153898-5	214	192501-3	214	193822-6	89	195004-6	233
153909-6	88	192541-1	89	193903-6	221	195005-4	233
154427-7	231	192547-9	125	193956-5	221	195007-0	233
154676-6	218	192562-3	231	194033-6	88	195008-8	233
154767-3	218	192563-1	231	194034-4	88	195012-7	233
154768-1	218	192613-2	160	194041-7	89	195017-7	233
158024-1	105	192622-1	215	194043-3	216	195018-5	233
158045-3	208	192628-9	215	194053-0	216	195020-8	233
158057-6	219	192629-7	221	194079-2	89	195021-6	233
158131-0	219	192664-5	89	194080-7	89	195022-4	233
158969-3	214	192669-5	215	194086-5	214	195023-2	233
158970-8	214	192671-8	214	194087-3	214	195024-0	233
161509-8	207	192672-6	215	194088-1	105	195025-8	233
161510-3	207	192673-4	214	194090-4	105	195048-6	220
163424-2	218	192692-0	88	194092-0	88	195057-5	233
164021-7	214	192732-4	125	194093-8	215	195081-8	89
164095-8	214	192733-2	124	194175-6	216	195087-6	89
164113-2	125	192797-6	214	194241-9	214	195103-4	233
164379-4	191	192798-4	214	194285-9	233	195113-1	233
164393-0	191	192891-4	88	194289-1	221	195114-9	233

ÍNDICE

195191-1	233	196616-8	207	224223-8	213	321492-3	190
195192-9	233	196749-9	205	224241-6	213	321812-1	190
195195-3	233	196751-2	205	224256-3	213	322119-8	83
195198-7	233	196846-1	218	224257-1	213	322120-3	83
195199-5	233	196858-4	220	224264-4	213	322124-5	83
195201-4	233	196865-7	233	224268-6	213	322125-3	83
195204-8	233	196918-2	233	224274-1	214	322126-1	83
195205-6	233	197030-1	205	224275-9	214	322279-6	83
195206-4	233	197148-8	220	224276-7	213	322312-4	214
195231-5	105	197163-2	207	224280-6	213	322932-4	214
195236-5	218	197168-2	220	224298-7	213	323015-A	221
195253-5	215	197188-6	205	224299-5	214	323018-7	191
195263-2	233	197189-4	205	224303-0	213	323726-0	214
195298-3	205	197195-9	106	224308-0	213	325673-1	214
195299-1	205	197210-9	91	224309-8	213	332059-2	207
195300-2	205	197211-7	91	224310-3	213	342332-2	160
195386-6	218	197212-5	91	224317-9	213	342428-9	191
195433-3	231	197213-3	91	224333-1	214	342526-9	160
195436-7	231	197472-9	206	224347-0	213	342554-4	218
195438-3	231	197473-7	206	224355-1	214	343355-3	160
195441-4	231	197474-5	206	224360-8	213	343577-5	192
195446-4	221	197475-3	206	224366-6	213	344364-5	191
195521-6	205	197738-7	206	224377-1	213	344443-9	125
195532-1	210	197804-0	205	224385-2	213	346666-5	207
195544-4	231	197806-6	205	224394-1	213	351011-000	125
195545-2	231	197808-2	205	224395-9	213	375009-000	233
195546-0	231	197912-7	160	224396-7	213	369224600	206
195547-8	231	197914-3	160	224399-1	213	369224601	206
195548-6	231	197916-9	160	224403-6	213	369224602	206
195551-7	230	197918-5	160	224409-4	213	369224604	206
195552-5	231	197920-8	160	224411-7	213	369224606	206
195553-3	231	198306-9	92	224428-0	213	369224607	206
195554-1	231	198307-7	92	224429-8	213	369224608	206
195555-9	231	198384-9	205	224431-1	213	369224609	206
195598-3	205	198730-6	231	224432-9	213	369224611	206
195611-5	231	198746-1	231	224458-1	213	369224612	206
195612-3	231	198748-7	231	224467-0	213	369224613	206
195624-6	205	198752-6	231	224501-6	213	369224614	206
195645-8	207	198759-2	205	224505-8	213	369224615	206
195686-4	205	199090-9	192	224512-1	213	369224616	206
195706-4	205	224019-7	213	224517-1	213	410306-2	230
195720-0	205	224047-2	213	224526-0	213	410602-8	160
195729-2	205	224080-4	213	224568-4	213	411292-0	83
195798-3	105	224081-2	213	224573-1	213	412010-9	188
195845-0	233	224083-8	213	224577-3	213	412028-0	188
195871-9	56	224089-6	213	252627-4	190	412088-2	188
195921-0	205	224090-1	213	256241-8	231	413068-1	125
195927-8	105	224111-9	213	256812-1	214	415252-4	160
196074-8	220	224118-5	213	257022-3	114	415253-2	193
196094-2	193	224119-3	213	257060-5	114	415887-1	124
196092-6	193	224137-1	213	273472-4	219	415946-1	231
196093-4	193	224141-0	213	281220-7	105	415962-3	231
196129-9	207	224151-7	213	302040600N	127	415964-9	230
196142-7	207	224160-6	213	313249-6	173	415965-7	230
196352-6	106	224184-2	213	315113-7	223	416041-0	230
196454-8	233	224201-8	213	321308-2	191	416256-9	218
196499-6	207	224207-6	213	321472-9	191	416299-1	218

ÍNDICE

416311-7	105	711207-A	57	711440-A	57	742526-A	150
416368-8	216	711208-A	57	711441-A	57	742526-A50	150
416477-3	124	711209-A	57	711442-A	57	742527-A	150
417322-5	221	711210-A	57	711443-A	57	742527-A50	150
417383-5	105	711211-A	57	711444-A	57	743015-1	221
417476-8	105	711212-A	57	711445-A	57	743022-A	160
417605-3	105	711213-A	57	711446-A	57	743025-8	221
417615-0	105	711214-A	57	711447-A	57	743027-4	221
417616-8	105	711215-A	57	711448-A	57	743032-1	160
418066-0	105	711216-A	57	711449-A	57	743033-9	221
418558-9	188	711217-A	57	711450-A	57	743036-3	221
419360-3	216	711218-A	57	711451-A	57	743052-5	221
421342-3	105	711219-A	57	711452-A	57	743056-7	160
423154-0	220	711220-A	57	711453-A	57	743081-8	160
423319-4	193	711221-A	57	711454-A	57	743327-2	231
443060-3	231	711222-A	57	711499-A	54	743328-0	230
443122-7	219	711223-A	57	711502-A	54	743403-A	221
450688-0	106	711224-A	57	711503-A	54	751101-A	64
451208-3	231	711226-A	53	711504-A	54	751102-A	64
451271-6	160	711227-A	53	711505-A	54	751103-A	63
451622-3	160	711228-A	53	711506-A	54	751106-A	64
451623-1	160	711229-A	53	711507-A	54	751220-A	63
452123-4	230	711230-A	53	711509-A	54	751221-A	64
453506-1	207	711231-A	53	711510-A	54	751222-A	63
453507-9	207	711232-A	53	711511-A	54	751224-A	62
453699-4	207	711234-A	53	711512-A	54	751225-A	62
453700-5	207	711235-A	53	711513-A	54	751226-A	63
456336-9	105	711236-A	53	711514-A	54	751227-A	63
6005L	144	711237-A	53	711515-A	54	751420-A	63
6005R	144	711238-A	53	711517-A	54	751421-A	62
6105L	144	711239-A	53	711518-A	54	751422-A	62
6105R	144	711240-A	53	711519-A	54	751621-A	64
638651-5	214	711241-A	53	711520-A	54	751622-A	64
711173-A	53	711242-A	53	711521-A	54	751623-A	63
711174-A	53	711243-A	53	721005A	112	751624-A	63
711175-A	53	711244-A	53	723051-A5	122	751625-A	65
711176-A	53	711245-A	53	723059-A5	120	751703-A	64
711177-A	53	711248-A	53	723060-A5	120	751710-A	63
711178-A	53	711249-A	53	723061-A5	120	751711-A	63
711179-A	53	711250-A	53	723062-A5	120	751712-A	63
711180-A	53	711251-A	53	723064-A5	120	751713-A	63
711191-A	57	711252-A	53	724115-A	143	751715-A	65
711192-A	57	711253-A	53	725092-5	125	751716-A	63
711193-A	57	711255-A	53	725093-3	125	751717-A	64
711194-A	57	711256-A	53	725094-1	125	752103-A	57
711195-A	57	711257-A	53	725129-8	125	752104-A	57
711196-A	57	711258-A	53	725130-3	125	752106-A	57
711197-A	57	711430-A	57	725184-0	207	752107-A	57
711198-A	57	711431-A	57	733229-0	190	752108-A	57
711199-A	57	711432-A	57	733232-1	190	752113-A	57
711200-A	57	711433-A	57	741015-5	145	752117-A	57
711201-A	57	711434-A	57	741016-3	145	752124-A	57
711202-A	57	711435-A	57	741402-B	140	752136-A	57
711203-A	57	711436-A	57	741616-9	145	752140-A	57
711204-A	57	711437-A	57	741617-7	145	752141-A	57
711205-A	57	711438-A	57	742137-A	150	752142-A	57
711206-A	57	711439-A	57	742137-A50	150	752143-A	57

ÍNDICE

752173-A	57	764381-3	88	784820-A	85	794609-5	151
762007-1	126	764382-1	88	785501-AA	85	798029-5	63
762013-6	126	764383-9	88	785508-A	85	798139-8	63
763011-3	89	764416-0	88	785509-A	85	798140-3	63
763062-6	89	764418-6	88	785510-A	85	798146-1	63
763078-1	89	764419-4	88	785511-A	85	798147-9	63
763103-8	88	764420-9	88	791024-4	57	824772-1	215
763110-1	88	766005-7	88	791134-7	57	8005L	144
763161-4	89	766007-3	88	791135-5	57	8005R	144
763170-3	89	766008-1	88	791172-9	208	831271-6	229
763172-9	89	766015-4	90	792003-5	120	831278-2	229
763173-7	89	766023-5	90	792010-8	112	831279-0	229
763174-5	89	781003-0	127	792147-1	121	831342-9	207
763178-7	89	781006-4	127	792265-5	125	A-01323	180
763180-0	88	781008-0	127	792287-5	125	A-07179	180
763181-8	88	781011-1	127	792289-1(EN)	179	A-07369(EN)	179
763185-0	88	781019-5	127	792292-2	125	A-07397	126
763191-5	88	781027-6	127	792299-8	112	A-07406	126
763193-1	88	781028-4	127	792533-6	125	A-11645	187
763198-1	89	781030-7	127	792534-4	125	A-11667	187
763415-9	89	781031-5	127	792536-0	125	A-11673	187
763427-2	89	781041-2	127	792537-8	125	A-11689	187
763429-8	89	781206-6	127	792559-8	124	A-11704	187
763432-9	89	781213-9	127	792728-1	125	A-11710	187
763434-5	89	782016-4	127	792742-7	125	A-11726	187
763441-8	89	782021-1	127	792743-5	125	A-11732	187
763442-6	89	782203-5	127	792744-3	125	A-11748	187
763443-4	89	782209-3	127	793008-8	126	A-11760	187
763606-2	192	782210-8	127	793011-9	126	A-11807	187
763608-8	192	782212-4	127	793013-5	126	A-15051	125
763609-6	192	782401-1	127	793015-1	126	A-15992	207
763610-1	192	782407-9	127	793186-4	126	A-24642	145
763619-3	192	782412-6	127	793346-8	126	A-25214	62
763620-8	192	782420-7	127	794060-9	126	A-31485	65
763622-4	192	782424-9	127	794063-3	145	A-33065	223
763623-2	192	783201-2	127	794217-2	145	A-33071	224
763625-8	192	783202-0	127	794379-6	133	A-34447	157
763626-6	192	783203-8	127	794380-1	133	A-34453	157
763629-0	192	783204-6	127	794382-7	133	A-34469	157
763637-1	192	783207-0	127	794383-5	133	A-34475	157
763642-8	192	783210-1	127	794384-3	133	A-34481	157
763643-6	192	783223-2	127	794518-8	150	A-34534	156
763645-2	192	784211A250	83	794518-8-50	150	A-34540	156
763661-4	192	784217-A	72	794519-6	150	A-34556	156
763663-0	192	784312A250	83	794519-6-50	150	A-34562	156
763664-8	192	784607-A	72	794520-1	150	A-34578	156
763668-0	192	784610-A	72	794520-1-50	150	A-34584	156
763674-5	192	784611-A	72	794521-9	150	A-34590	156
763803-0	192	784612-A	72	794521-9-50	150	A-34609	156
763805-6	192	784801-1	85	794522-7	150	A-36712	29
764352-0	88	784802-9	85	794522-7-50	150	A-37471	230
764353-8	88	784803-7	85	794523-A	150	A-43670	223
764361-9	88	784804-5	85	794523-A50	150	A-43686	223
764362-7	88	784805-3	85	794544-7	150	A-43692	223
764363-5	88	784807-9	85	794558-6	160	A-43701	223
764364-3	88	784811-8	85	794559-4	160	A-43717	223
764380-5	88	784819-A	85	794560-9	160	A-43723	223

A-43739	223	A-85765	118	A-91908-10	158	A-92857-5	156
A-43745	224	A-85771	118	A-91914-10	158	A-92863-5	156
A-43751	224	A-85787	118	A-91920-10	158	A-92879-5	156
A-43773	224	A-85793	117	A-91936-10	158	A-92885-5	156
A-43795	224	A-86290	117	A-91942-10	158	A-92891-5	156
A-49105	211	A-86321(EN)	179	A-91958-10	158	A-92900-5	156
A-49127	211	A-86561	118	A-91964-10	158	A-92916-5	156
A-49563	72	A-86577	117	A-91970-10	159	A-92922-5	156
A-49585	72	A-86583	117	A-91986-10	159	A-92938-5	156
A-49600	72	A-86745	143	A-91992-10	159	A-93887	112
A-49884	106	A-86860	177	A-92003-10	159	A-93893	112
A-50120	72	A-87694-25	143	A-92019-10	159	A-93902	113
A-50924	72	A-87812	160	A-92025-10	159	A-93918	113
A-51225	105	A-88490	140	A-920315	149	A-94530	111
A-56932	205	A-89121	206	A-920475	149	A-94720	181
A-80400	117	A-89143	206	A-920535	149	A-94736	181
A-80597	64	A-89523	206	A-92075-5	151	A-94982	193
A-80787	61	A-89872-25	143	A-92081-5	151	A-95118	112
A-80793	61	A-90093	112	A-92097-5	151	A-95934	110
A-80802	62	A-90451	114	A-92106-5	151	A-96132	113
A-80818	62	A-90532	113	A-92112-5	151	A-96235	87
A-80824	62	A-91039	113	A-92128-5	151	A-96241	87
A-80830	62	A-91447	143	A-92184-5	151	A-96257	87
A-81359	112	A-91453	143	A-92271-5	151	A-96263	87
A-81496	111	A-91481-10	157	A-92293-5	151	A-96279	87
A-81505	111	A-91497-10	157	A-92302-5	151	A-96285	87
A-81658	206	A-91506-10	157	A-92318-5	151	A-96291	87
A-83951	125	A-91512-10	157	A-92558-5	156	A-96300	87
A-84056	186	A-91528-10	158	A-92564-5	156	A-96316	87
A-84109	181	A-91534-10	158	A-92570-5	156	A-96322	87
A-84115	181	A-91540-10	158	A-92586-5	156	A-96338	87
A-84121	181	A-91556-10	159	A-92592-5	156	A-96344	87
A-84137	181	A-915562	159	A-92601-5	156	A-96350	87
A-84143	186	A-91562-10	159	A-92617-5	156	A-96366	87
A-84159	186	A-91578-10	159	A-92623-5	155	A-96372	87
A-84165	186	A-91584-10	159	A-92639-5	156	A-96394	87
A-84171	186	A-91590-10	159	A-92645-5	156	A-96453	75
A-85232	117	A-91609-10	159	A-92651-5	156	A-96469	75
A-85248	177	A-91621-10	159	A-92667-5	156	A-96475	75
A-85254	143	A-91637-10	159	A-92673-5	156	A-96481	75
A-85276	143	A-91643-10	159	A-92689-5	156	A-96497	75
A-85282	143	A-91659-10	159	A-92695-5	156	A-96506	78
A-85400	126	A-91665-10	157	A-92704-5	156	A-96512	78
A-85628	117	A-91671-10	157	A-92710-5	156	A-96528	78
A-85634	117	A-91687-10	158	A-92726-5	156	A-96534	78
A-85640	117	A-91693-10	158	A-92732-5	156	A-96540	77
A-85656	117	A-91702-10	158	A-92748-5	156	A-96556	77
A-85662	117	A-91724-10	159	A-92754-5	156	A-96562	77
A-85678	117	A-91746-10	159	A-92760-5	156	A-96578	77
A-85684	117	A-91768-10	159	A-92776-5	156	A-96584	77
A-85690	117	A-91780-10	159	A-92782-5	156	A-96590	77
A-85709	117	A-91796-10	159	A-92798-5	155	A-96609	77
A-85715	118	A-91805-10	159	A-92807-5	155	A-96615	78
A-85721	119	A-91861-10	158	A-92813-5	155	A-96621	77
A-85737	118	A-91877-10	158	A-92829-5	155	A-96637	77
A-85743	118	A-91880-10	158	A-92835-5	155	A-96643	76
A-85759	118	A-91899-10	158	A-92841-5	156	A-96659	76

ÍNDICE

A-96665	76	A-97237	81	A-99188	77	B-04743	54
A-96671-10	76	A-97243	81	A-99194	79	B-04765	54
A-96687	76	A-97259	81	A-99203	79	B-05038	122
A-96693	78	A-97265	81	A-99219	79	B-05038-25	122
A-96702	79	A-97302-10	75	A-99225	77	B-05044	122
A-96718	78	A-97324	75	A-99231	77	B-05044-25	122
A-96724	78	A-97330-10	78	A-99247	77	B-05153	122
A-96730	78	A-97368	76	A-99253	79	B-05153-25	122
A-96746	78	A-97380	80	A-99269	79	B-05169	121
A-96752	78	A-97396	80	A-99275	79	B-05169-25	121
A-96768	78	A-97405-10	78	A-99281	80	B-05175	121
A-96774	78	A-97639	81	A-99297	80	B-06292	118
A-96780	78	A-97645	81	A-99306	80	B-06345	153
A-96796	77	A-97651	81	A-99312	80	B-06351	153
A-96805	77	A-97667	81	A-99328	80	B-06367	153
A-96811	76	A-97673	81	A-99334	80	B-06373	153
A-96827	76	A-97689	81	A-99340	80	B-06395	153
A-96833	76	A-97695	81	A-99356	80	B-06404	153
A-96849	79	A-98326	81	A-99362	80	B-06410	153
A-96855	79	A-98332	81	A-99378	80	B-06426	153
A-96861	79	A-98348	81	A-99384	80	B-06460	117
A-96877	77	A-98778	111	A-99390	81	B-06476	117
A-96883	77	A-98821	75	A-99409	81	B-06482	117
A-96899	77	A-98837	75	A-99415	81	B-06890	119
A-96908	79	A-98843-10	75	A-99421	81	B-06909	119
A-96914	77	A-98859	75	A-99437	81	B-06921	62
A-96920	79	A-98865	76	A-99443	81	B-07250	123
A-96936	80	A-98887	78	A-99459	81	B-07353	110
A-96942	79	A-98893	78	A-99465	81	B-07375	206
A-96958	79	A-98902	77	A-99471	81	B-07406	54
A-96964	79	A-98918	77	A-99487	81	B-07428	54
A-96970	80	A-98924	77	A-99493	81	B-10300	65
A-96986	80	A-98930	77	A-99502	81	B-10372	63
A-96992	80	A-98946	77	A-99661	40	B-10394	123
A-97003	80	A-98952	77	A-99677	40	B-10403	123
A-97019	80	A-98968	77	A-99683	40	B-10609	123
A-97025	80	A-98974	76	A-99699	40	B-10621	61
A-97031	80	A-98980	76	A-99708	40	B-10637	123
A-97047	80	A-98996	76	A-99714	40	B-11265	43
A-97053	81	A-99007	79	A-99720	40	B-11271	43
A-97069	81	A-99013	79	A-99736	40	B-11287	43
A-97075	80	A-99029	79	A-99742	40	B-11293	43
A-97081	80	A-99035	78	ADAPTER	207	B-11302	43
A-97097	81	A-99041	78	ADP05	105	B-11318	43
A-97106	81	A-99057	78	B-00804	120	B-11324	43
A-97112	81	A-99063	78	B-00810	120	B-11330	43
A-97128	81	A-99079	78	B-00832	120	B-11346	43
A-97134	81	A-99085	78	B-01959	206	B-11352	43
A-97140	81	A-99091	78	B-01971	206	B-11368	43
A-97156	81	A-99100	76	B-02864	126	B-11374	43
A-97162	81	A-99116	76	B-02870	126	B-11380	43
A-97178	81	A-99122	76	B-02945	206	B-11396	43
A-97184	81	A-99138	79	B-02951	206	B-11405	43
A-97190	81	A-99144	79	B-03551	111	B-11411	43
A-97209	81	A-99150	79	B-03676	111	B-11427	43
A-97215	81	A-99166	77	B-04684	54	B-11433	43
A-97221	81	A-99172	77	B-04737	54	B-11449	43

B-11455	43	B-17778	54	B-19495	111	B-21353	167
B-11461	43	B-17784	54	B-19504	111	B-21369	167
B-11477	43	B-17809	54	B-19510	111	B-21381	167
B-11483	43	B-17815	54	B-19526	111	B-21406	167
B-11499	43	B-17821	54	B-19532	111	B-21412	167
B-11508	43	B-17837	54	B-19548	111	B-21428	168
B-11514	43	B-17843	54	B-19554	111	B-21434	168
B-11520	43	B-17859	54	B-19722	112	B-21440	169
B-11536	43	B-17865	54	B-19766	112	B-21456	169
B-11542	43	B-17887	54	B-19772	112	B-21462	170
B-11966	46	B-17893	54	B-19794	113	B-21478	170
B-11972	46	B-17902	54	B-19803	113	B-21484	170
B-11988	46	B-17918	54	B-20395	120	B-21490	171
B-12217-12	145	B-17924	54	B-20404	120	B-21509	171
B-12289	180	B-17946	54	B-20410	120	B-21515	171
B-12289 (EN)	179	B-17952	54	B-20426	120	B-21521	171
B-12295	178	B-17968	54	B-20432	120	B-21525	172
B-12295 (EN)	179	B-17974	54	B-20448	120	B-21537	172
B-12326	72	B-17980	54	B-20454	120	B-21559	175
B-12441	143	B-18035	56	B-20482	140	B-21565	175
B-12441-10	144	B-18041	56	B-20498	140	B-21571	175
B-12457	143	B-18057	56	B-20719	72	B-21587	175
B-12457-10	143	B-18063	56	B-20725	72	B-21593	175
B-12479	143	B-18079	56	B-20731	72	B-21602	175
B-12479-10	144	B-18188	46	B-20884	72	B-21618	175
B-12500	143	B-18194	43	B-20890	72	B-21624	175
B-12516	143	B-18275	140	B-20909	72	B-21630	175
B-12790	72	B-18297	140	B-20915	72	B-21646	175
B-13459	181	B-18306	140	B-20921	72	B-21652	175
B-13465	181	B-18356	140	B-20937	72	B-21674	175
B-13471	181	B-18502	140	B-20943	72	B-21680	175
B-13817	143	B-18524	140	B-20959	72	B-21696	175
B-14124	205	B-18530	140	B-20965	72	B-21705	175
B-14130	205	B-18580	140	B-20987	114	B-21711	175
B-14146	205	B-18605	140	B-20993	114	B-21727	175
B-14526	152	B-19118	111	B-21004	114	B-21733	175
B-14532	152	B-19124	111	B-21010	114	B-21749	175
B-14548	152	B-19130	111	B-21026	114	B-21755	175
B-14554	152	B-19146	110	B-21032	114	B-21761	175
B-14598-25	143	B-19152	110	B-21048	114	B-21777	175
B-14613	56	B-19168	110	B-21054	114	B-21783	175
B-14629	178	B-19174	110	B-21060	114	B-21799	175
B-15039	56	B-19233	111	B-21076	114	B-21808	175
B-15045	56	B-19249	111	B-21157	140	B-21814	175
B-16271	45	B-19255	111	B-21163	140	B-21820	175
B-16667	124	B-19261	111	B-21179	140	B-21836	72
B-16673	124	B-19364	111	B-21185	140	B-21842	72
B-16689	124	B-19392	111	B-21191	140	B-21858	72
B-16695	124	B-19401	111	B-21238	140	B-21864	72
B-16748	184	B-19417	111	B-21272	166	B-21870	72
B-16754	43	B-19423	111	B-21288	166	B-21886	72
B-16760	43	B-19439	111	B-21294	166	B-21892	72
B-16782	122	B-19445	111	B-21303	166	B-21901	72
B-16782-25	122	B-19451	111	B-21319	166	B-21917	72
B-16835	122	B-19467	111	B-21325	166	B-21923	72
B-17756	54	B-19473	111	B-21331	166	B-21939	72
B-17762	54	B-19489	111	B-21347	167	B-21945	72

ÍNDICE

B-22668	175	B-26179	82	B-28547	70	B-30106	35
B-22925	183	B-26185	82	B-28553	70	B-30112	35
B-22931	175	B-26191	82	B-28569	70	B-30514-25	143
B-22947	175	B-26238	83	B-28575	70	B-30564	123
B-22953	175	B-26244	83	B-28597	70	B-30570	123
B-22969	175	B-26250	83	B-28709	118	B-30586	172
B-23145	113	B-26266	82	B-28715	118	B-30592	172
B-23248	123	B-26272	82	B-28721	118	B-30601	172
B-23254	123	B-26288	82	B-28896	84	B-30617	172
B-23341	113	B-26294	82	B-28911	84	B-30623	172
B-23385	113	B-26303	82	B-28933	69	B-30639	172
B-23519	82	B-26319	82	B-28949	69	B-30754	70
B-23531	82	B-26325	82	B-28955	69	B-31011	33
B-23547	82	B-26490	83	B-29511	182	B-31027	33
B-23569	82	B-26515	83	B-29670	44	B-31033	33
B-24181	82	B-26571	83	B-29686	44	B-31049	33
B-24197	82	B-26593	83	B-29692	44	B-31055	33
B-24228	82	B-26674	26	B-29701	44	B-31061	33
B-24511	82	B-26680	26	B-29717	44	B-31077	33
B-24527	82	B-26733	26	B-29723	44	B-31083	33
B-24533	82	B-26749	26	B-29739	44	B-31099	33
B-24577	83	B-26777	26	B-29745	44	B-31108	33
B-24583	83	B-26783	26	B-29751	44	B-31114	33
B-24599	83	B-26820	26	B-29767	44	B-31120	33
B-24608	82	B-26836	26	B-29773	44	B-31136	33
B-24614	82	B-26842	26	B-29789	44	B-31681	113
B-24620	82	B-26858	26	B-29795	44	B-31706	43
B-24636	82	B-28167	69	B-29804	44	B-31712	43
B-24642	82	B-28173	69	B-29810	44	B-31728	43
B-24658	82	B-28189	69	B-29826	44	B-31734	43
B-24664	82	B-28195	69	B-29832	44	B-31740	43
B-24876	82	B-28204	69	B-29848	44	B-31756	43
B-24898	82	B-28210	69	B-29854	44	B-31762	43
B-24957	83	B-28226	69	B-29860	44	B-31778	43
B-24979	83	B-28232	69	B-29876	44	B-31843	121
B-25214	71	B-28248	69	B-29882	44	B-31859	121
B-25220	71	B-28254	69	B-29898	44	B-31865	121
B-25236	71	B-28260	69	B-29907	26	B-31871	123
B-25286	82	B-28276	69	B-29913	26	B-33912	113
B-25301	82	B-28282	69	B-29929	26	B-33928	113
B-25317	82	B-28298	69	B-29935	26	B-33934	113
B-25339	82	B-28307	69	B-29941	26	B-33940	113
B-25513	71	B-28313	69	B-29957	26	B-33956	113
B-25529	71	B-28329	69	B-29963	26	B-33962	113
B-25535	71	B-28357	69	B-29979	26	B-33978	113
B-25781	71	B-28379	69	B-29985	26	B-34160	153
B-25797	71	B-28391	69	B-29991	26	B-34176	153
B-25806	71	B-28416	69	B-30003	35	B-34182	153
B-25812	71	B-28422	69	B-30019	35	B-34198	153
B-25828	71	B-28438	69	B-30025	35	B-34241	153
B-25834	71	B-28444	69	B-30031	35	B-34257	153
B-25840	71	B-28472	69	B-30047	35	B-34263	153
B-25856	71	B-28494	69	B-30053	35	B-34279	153
B-25862	71	B-28519	69	B-30069	35	B-34285	154
B-25878	82	B-28525	69	B-30075	35	B-34291	154
B-25884	82	B-28531	70	B-30081	35	B-34300	154
B-25915	82	B-28531-24	70	B-30097	35	B-34316	154

B-34366	154	B-39182	69	B-42438	71	B-45082	85
B-34372	154	B-39213	168	B-42444	71	B-45098	85
B-34388	154	B-39229	168	B-42472	73	B-45107	85
B-34394	154	B-39235	168	B-42488	73	B-45375	97
B-34643	172	B-39241	168	B-42494	73	B-45478	167
B-34659	172	B-39257	168	B-42503	73	B-45484	167
B-34665	172	B-39263	112	B-42519	73	B-45490	167
B-34671	172	B-39279	112	B-42525	73	B-45509	167
B-34805	171	B-39285	112	B-42575	71	B-45515	168
B-34811	171	B-39291	112	B-42606	112	B-45521	168
B-34827	170	B-39300	152	B-42612	112	B-45537	168
B-35433	143	B-39316	152	B-42628	112	B-45543	168
B-35994	44	B-39322	152	B-42634	112	B-45995	45
B-36005	44	B-39344	152	B-42874	72	B-46006	45
B-36011	44	B-39431	56	B-42961	89	B-46012	45
B-36027	44	B-39447	56	B-42977	89	B-46028	45
B-36033	44	B-39453	56	B-42983	89	B-46034	45
B-36049	44	B-39469	56	B-42999	89	B-46040	45
B-36055	44	B-39512	72	B-43000	84	B-46056	45
B-36061	44	B-39534	72	B-43169	121	B-46062	45
B-36077	44	B-39540	72	B-43197	121	B-46078	45
B-36083	44	B-39556	72	B-43240	121	B-46084	45
B-36099	44	B-39562	72	B-43262	121	B-46090	45
B-36108	44	B-40266	70	B-43290	89	B-46109	45
B-36114	44	B-40272	70	B-43309	89	B-46115	45
B-36120	44	B-40353	70	B-43315	89	B-46121	45
B-36136	44	B-40369	70	B-43321	89	B-46137	45
B-36142	44	B-40397	169	B-43337	89	B-46327	186
B-36619	153	B-40406	170	B-43343	89	B-46333	186
B-36631	153	B-40543	124	B-43359	89	B-46816	169
B-36653	153	B-40559	124	B-43365	89	B-46822	169
B-36675	153	B-40565	124	B-43371	89	B-46838	168
B-38071	163	B-41713	155	B-43387	89	B-46844	169
B-38087	163	B-41729	155	B-44052	140	B-46850	167
B-38093	163	B-41735	155	B-44074	143	B-46866	170
B-38124	163	B-41741	155	B-44096	140	B-47195	113
B-38130	163	B-41757	155	B-44105	140	B-47204	113
B-38174	163	B-41763	155	B-44111	140	B-47210	113
B-38180	163	B-41779	155	B-44127	143	B-47226	113
B-38196	163	B-41785	155	B-44155	140	B-48533	179
B-38227	163	B-41791	155	B-44161	140	B-48549	179
B-38233	163	B-41800	155	B-44183	140	B-48555	179
B-38249	163	B-41816	155	B-44199	140	B-48561	179
B-38277	163	B-41822	155	B-44208	143	B-48577	179
B-38320	163	B-41872	155	B-44220	140	B-48583	179
B-38336	163	B-41888	155	B-44236	140	B-48599	179
B-38370	163	B-41894	155	B-44242	143	B-48608	179
B-38386	163	B-41903	155	B-44264	140	B-48614	179
B-38392	163	B-41919	155	B-44270	141	B-48620	180
B-38794	85	B-41925	155	B-44286	140	B-48636	179
B-38803	85	B-41931	155	B-44292	141	B-48642	179
B-38819	85	B-41947	155	B-44301	140	B-48658	179
B-38825	85	B-41953	155	B-44410	119	B-48664	180
B-38831	85	B-41969	155	B-44426	119	B-48670	143
B-38847	87	B-41975	155	B-44432	122	B-48686	140
B-38853	87	B-41981	155	B-44448	122	B-48692	143
B-39160	69	B-42422	73	B-45076	85	B-48795	87

ÍNDICE

B-48804	87	B-51471	152	B-53718	185	B-57869	71
B-48810	87	B-51487	152	B-54081	86	B-57875	71
B-48826	87	B-51493	152	B-54293-25	143	B-57881	71
B-48832	112	B-51502	152	B-54302	39	B-59106	26
B-48848	143	B-51518	152	B-54318	39	B-59112	26
B-48860	112	B-51524	152	B-54324	39	B-59128	26
B-49373	96	B-51530	152	B-54330	39	B-59134	26
B-49389	94	B-51546	152	B-54411	85	B-59140	26
B-49432	94	B-51552	152	B-54461	114	B-59156	26
B-49507	143	B-51568	152	B-54477	114	B-59162	26
B-49513	143	B-51574	152	B-54645	86	B-59178	26
B-49529	141	B-51580	152	B-54651	86	B-59184	26
B-49535	141	B-51611	89	B-54667	86	B-59190	39
B-49541	141	B-51627	89	B-54673	86	B-59209	39
B-49703	123	B-51661	95	B-55304	188	B-59215	39
B-49719	123	B-51823	187	B-55326	188	B-59221	39
B-49725	97	B-51839	187	B-55348	188	B-59237	39
B-49834-10	123	B-51845	187	B-55603	154	B-59243	27
B-49840-10	123	B-51873	83	B-55619	154	B-59259	86
B-49856-10	123	B-51904	145	B-55625	154	B-59265	87
B-49878	143	B-51910	145	B-55631	154	B-59330	55
B-49884	97	B-51932	145	B-55647	154	B-59346	55
B-49890	85	B-51948	145	B-55653	154	B-59352	55
B-49909	85	B-51954	145	B-55669	154	B-59368	55
B-49915	73	B-51976	145	B-55675	154	B-59374	55
B-49921	73	B-52043	123	B-55697	87	B-59380	55
B-50005	179	B-52071	139	B-55734	86	B-59396	55
B-50273	95	B-52118	122	B-55740	86	B-59405	55
B-50289	70	B-52124	122	B-55756	86	B-59411	55
B-50304	141	B-52130	122	B-55815	121	B-59427	55
B-50310	141	B-52451	83	B-55821	121	B-59433	55
B-50326	141	B-52473	83	B-55837	121	B-59449	55
B-50332	141	B-52691	45	B-56524	110	B-59455	55
B-50348	141	B-52700	45	B-56574	110	B-59461	55
B-50354	141	B-52912	73	B-56580	123	B-59477	55
B-50360	140	B-52940	85	B-56596	123	B-59483	55
B-50706	169	B-52962	145	B-56948	72	B-59499	55
B-50712	169	B-52978	145	B-56954	72	B-59508	55
B-50784	89	B-52984	145	B-57118-25	143	B-59514	55
B-50790	89	B-52990	145	B-57370	110	B-59520	55
B-50809	89	B-53001	145	B-57386	123	B-59536	55
B-50815	89	B-53017	145	B-57392	123	B-59542	55
B-50821	89	B-53023	145	B-57716	182	B-59558	55
B-50837	89	B-53039	145	B-57722	182	B-59564	55
B-50843	89	B-53045	145	B-57738	86	B-59570	55
B-50859	89	B-53051	145	B-57744	86	B-59586	55
B-50865	89	B-53067	145	B-57750	83	B-59592	55
B-50871	89	B-53073	145	B-57776	83	B-59601	55
B-51281	113	B-53089	145	B-57772	71	B-59617	55
B-51297	113	B-53095	145	B-57788	71	B-59623	55
B-51312	123	B-53104	145	B-57794	71	B-59639	55
B-51415	152	B-53160	180	B-57803	71	B-59645	55
B-51421	152	B-53176	180	B-57819	71	B-59651	55
B-51437	152	B-53235	110	B-57825	71	B-59667	55
B-51443	152	B-53241	110	B-57831	71	B-59673	55
B-51459	152	B-53687	185	B-57847	71	B-59689	55
B-51465	152	B-53702	185	B-57853	71	B-59695	55

B-59704	55	B-61933	52	D-01018	50	D-02076	194
B-59710	55	B-62016	123	D-01018-25	51	D-02107	194
B-59726	55	B-62038	114	D-01024	50	D-02129	195
B-59732	55	B-62072	85	D-01024-25	51	D-02141	195
B-59748	55	B-62290	141	D-01030	50	D-02163	195
B-59754	55	B-62309	141	D-01030-25	51	D-02185	195
B-59760	55	B-62315	141	D-01046	50	D-02191	195
B-59776	55	B-62321	141	D-01046-25	51	D-02216	195
B-59829	55	B-80210	207	D-01052	50	D-02244	195
B-59835	86	B-80226	207	D-01052-25	51	D-02250	195
B-59841	86	BASE 4100NH2R	187	D-01068	50	D-02266	195
B-59879	71	BASE 4100NH2V	187	D-01068-25	51	D-02319	195
B-59885	71	BML184	106	D-01074	50	D-02325	195
B-59891	71	BML803	106	D-01074-25	51	D-02347	195
B-59900	71	Chuc 05	35	D-01270	194	D-02397	195
B-59916	71	D-00804	50	D-01286	194	D-02406	195
B-59922	71	D-00804-25	50	D-01292	194	D-02428	195
B-59938	71	D-00810	50	D-01301	194	D-02478	195
B-59944	71	D-00810-25	50	D-01317	194	D-02484	195
B-59950	71	D-00826	50	D-01323	194	D-02509	195
B-59966	71	D-00826-25	50	D-01345	194	D-02537	195
B-59972	71	D-00832	50	D-01367	194	D-02571	195
B-59988	71	D-00832-25	50	D-01373	194	D-02593	195
B-59994	71	D-00848	50	D-01389	194	D-02618	195
B-60006	71	D-00848-25	50	D-01395	194	D-02652	196
B-60109	206	D-00854	50	D-01404	194	D-02668	196
B-60121	206	D-00854-25	50	D-01410	194	D-02680	196
B-60143	206	D-00860	50	D-01426	194	D-02711	196
B-60470	141	D-00860-25	50	D-01432	194	D-02749	196
B-60486	141	D-00876	50	D-01448	194	D-02967	195
B-61662	52	D-00876-25	50	D-01507	194	D-03056	196
B-61678	52	D-00882	50	D-01513	194	D-03062	196
B-61684	52	D-00882-25	50	D-01529	194	D-03078	196
B-61690	52	D-00898	50	D-01622	194	D-03084	196
B-61709	52	D-00898-25	50	D-01638	194	D-03090	196
B-61715	52	D-00907	50	D-01644	193	D-03109	196
B-61721	52	D-00907-25	50	D-01650	193	D-03115	196
B-61737	52	D-00913	50	D-01672	194	D-03137	196
B-61743	52	D-00913-25	51	D-01688	194	D-03143	197
B-61759	52	D-00929	50	D-01719	194	D-03171	196
B-61765	52	D-00929-25	51	D-01725	194	D-03187	197
B-61771	52	D-00935	50	D-01731	194	D-03193	197
B-61787	52	D-00935-25	51	D-01747	194	D-03230	197
B-61793	52	D-00941	50	D-01753	194	D-03246	197
B-61802	52	D-00941-25	51	D-01775	194	D-03252	197
B-61818	52	D-00957	50	D-01781	194	D-03377	110
B-61824	52	D-00957-25	51	D-01828	194	D-03436	110
B-61830	52	D-00963	50	D-01840	194	D-03464	112
B-61846	52	D-00963-25	51	D-01878	193	D-03486	113
B-61852	52	D-00979	50	D-01884	193	D-03925	110
B-61868	52	D-00979-25	51	D-01909	193	D-05197-10	180
B-61874	52	D-00985	50	D-01915	193	D-05212	182
B-61880	52	D-00985-25	51	D-01937	193	D-07945	126
B-61896	52	D-00991	50	D-01943	193	D-07951	126
B-61905	52	D-00991-25	51	D-01965	193	D-07967	126
B-61911	52	D-01002	50	D-01987	194	D-07973	51
B-61927	52	D-01002-25	51	D-02054	194	D-08034	61

ÍNDICE

D-08676	62	D-21353-5	63	D-22333	25	D-22919	28
D-08713	61	D-21369-5	63	D-22349	25	D-22925	28
D-08729	61	D-21521	110	D-22355	25	D-22931	28
D-08735	61	D-21618	43	D-22361	25	D-22947	28
D-14093	89	D-21624	43	D-22377	25	D-22953	28
D-15279	64	D-21630	43	D-22383	25	D-22969	28
D-15285	64	D-21646	43	D-22399	25	D-22975	28
D-15291	64	D-21652	43	D-22408	25	D-22981	28
D-15300	64	D-21668	43	D-22414	25	D-22997	28
D-15584	187	D-21674	43	D-22420	25	D-23008	28
D-15590	187	D-21680	43	D-22436	25	D-23014	28
D-15609	187	D-21696	43	D-22442	25	D-23020	28
D-15615	187	D-21705	43	D-22458	25	D-23036	28
D-15621	187	D-21711	43	D-22464	25	D-23042	28
D-15637	187	D-21727	43	D-22470	25	D-23058	28
D-15643	187	D-21733	43	D-22486	25	D-23064	28
D-15659	187	D-21749	43	D-22492	25	D-23070	28
D-16346	126	D-21755	43	D-22501	25	D-23086	28
D-16449	29	D-21761	43	D-22517	25	D-23092	28
D-16461	199	D-21777	43	D-22523	28	D-23189	38
D-17647	63	D-21783	43	D-22539	28	D-23195	38
D-17675	63	D-21799	43	D-22545	28	D-23204	38
D-17681	63	D-21808	43	D-22551	28	D-23210	38
D-18188	144	D-21814	43	D-22567	28	D-23226	38
D-18194	144	D-21820	43	D-22589	28	D-23232	38
D-18203	144	D-21836	43	D-22595	28	D-23248	38
D-18219	144	D-21842	43	D-22604	28	D-23254	38
D-18225	144	D-21864	43	D-22610	28	D-23260	38
D-18231	144	D-21870	45	D-22626	28	D-23276	38
D-18247	144	D-21886	45	D-22632	28	D-23282	38
D-18253	144	D-21945	25	D-22648	28	D-23298	38
D-18275	144	D-21951	25	D-22654	28	D-23307	38
D-18281	144	D-21967	25	D-22660	28	D-23313	39
D-18297	144	D-21973	25	D-22676	28	D-23329	39
D-18306	144	D-21989	25	D-22682	28	D-23335	39
D-18312	144	D-21995	25	D-22698	28	D-23341	39
D-18328	144	D-22006	25	D-22707	28	D-23357	39
D-18334	144	D-22012	25	D-22713	28	D-23363	39
D-18340	144	D-22028	25	D-22729	28	D-23379	39
D-18356	144	D-22034	25	D-22735	28	D-23385	39
D-18362	144	D-22040	25	D-22741	28	D-23391	39
D-18378	144	D-22056	25	D-22757	28	D-23400	39
D-18384	144	D-22062	25	D-22763	28	D-23416	39
D-18390	144	D-22078	25	D-22779	28	D-23422	39
D-18409	144	D-22084	25	D-22785	28	D-23438	39
D-18415	144	D-22096	25	D-22791	28	D-23444	39
D-18421	144	D-22109	25	D-22800	28	D-23450	39
D-18437	144	D-22230	25	D-22816	28	D-23466	39
D-19015	61	D-22246	25	D-22822	28	D-23472	39
D-19021	61	D-22252	25	D-22838	28	D-23488	39
D-19059	112	D-22268	25	D-22844	28	D-23494	39
D-19065	112	D-22274	25	D-22850	28	D-23503	39
D-19788	112	D-22280	25	D-22866	28	D-23519	39
D-20688	110	D-22296	25	D-22872	28	D-23525	39
D-20725	64	D-22305	25	D-22888	28	D-23531	39
D-20769	26	D-22311	25	D-22894	28	D-23547	39
D-21347-5	64	D-22327	25	D-22903	28	D-23553	39

ÍNDICE

D-23569	39	D-24599	38	D-31946	155	D-35972	39
D-23575	39	D-24608	38	D-31952	155	D-35988	39
D-23581	38	D-24614	38	D-31968	155	D-36027	49
D-23597	41	D-24636	38	D-31974	155	D-36033	49
D-23606	41	D-24658	38	D-31980	155	D-36332	187
D-23612	39	D-24670	38	D-31996	155	D-36348	187
D-23765	38	D-24907	43	D-32007	155	D-36463	61
D-23868	65	D-24913	43	D-32013	155	D-36479	61
D-23874	27	D-24935	43	D-32029	155	D-36485	62
D-23880	27	D-24941	43	D-32035	155	D-36491	62
D-23896	27	D-24957	43	D-32041	155	D-36516	62
D-23905	27	D-25183	49	D-32057	155	D-36522	62
D-23911	27	D-25199	49	D-32063	155	D-36538	54
D-23927	27	D-25208	49	D-32079	155	D-36544	54
D-23933	27	D-25214	49	D-32085	155	D-36550	54
D-23949	27	D-25220	49	D-32091	155	D-36566	54
D-23955	38	D-25236	49	D-32100	155	D-36572	54
D-23961	38	D-26490	38	D-32493	155	D-36588	54
D-23977	38	D-26509	38	D-34350	45	D-36594	54
D-23983	38	D-26515	132	D-34366	84	D-36603	54
D-23999	38	D-26521	132	D-34811	64	D-36619	54
D-24000	38	D-26537	133	D-34849	84	D-36625	54
D-24016	38	D-26543	133	D-34877	119	D-36631	54
D-24022	38	D-26559	133	D-34883	119	D-36647	54
D-24038	49	D-26602	62	D-34899	119	D-36653	54
D-24044	49	D-26751	62	D-34908	119	D-36669	54
D-24050	49	D-29228	64	D-35318	27	D-36675	54
D-24309	49	D-29907	25	D-35673	39	D-36681	54
D-24315	49	D-29935	38	D-35689	39	D-36697	54
D-24321	49	D-29957	38	D-35695	39	D-36706	54
D-24337	49	D-29963	38	D-35704	39	D-36837	185
D-24343	49	D-29979	38	D-35710	39	D-36859	49
D-24359	49	D-29985	38	D-35726	39	D-36865	49
D-24365	49	D-29991	38	D-35732	39	D-36871	49
D-24365-20	49	D-30003	38	D-35748	39	D-36887	49
D-24371	49	D-30019	38	D-35754	39	D-36893	49
D-24387	49	D-30025	38	D-35760	39	D-36902	49
D-24393	49	D-30031	38	D-35776	39	D-36918	49
D-24402	49	D-30047	38	D-35782	39	D-36924	49
D-24402-20	49	D-30112	27	D-35798	39	D-36930	49
D-24418	49	D-30601	25	D-35807	39	D-36946	49
D-24424	49	D-30623	184	D-35813	39	D-36952	49
D-24430	49	D-30639	184	D-35829	39	D-36968	182
D-24430-20	49	D-30667	84	D-35835	39	D-36980	94
D-24446	49	D-30667-12	84	D-35841	39	D-37029	50
D-24452	49	D-31083	84	D-35857	39	D-37100	50
D-24468	49	D-31083-12	84	D-35863	39	D-37219	25
D-24480	49	D-31619	84	D-35879	39	D-37552	180
D-24496	49	D-31619-12	84	D-35885	39	D-37568	180
D-24505	38	D-31647	83	D-35891	39	D-37574	180
D-24511	38	D-31669	83	D-35900	39	D-37574-10	180
D-24527	38	D-31697	132	D-35916	39	D-37580	180
D-24533	38	D-31706	133	D-35922	39	D-37596	186
D-24549	38	D-31712	133	D-35938	39	D-37605	186
D-24561	38	D-31728	110	D-35944	39	D-37611	186
D-24577	38	D-31734	51	D-35950	39	D-37627	186
D-24583	38	D-31762	84	D-35966	39	D-37758	187

ÍNDICE

D-37764	187	D-40082	32	D-45004	184	D-49270	198
D-38261	184	D-40098	32	D-45456	143	D-49286	198
D-38277	183	D-40107	32	D-45484	143	D-49292	198
D-38504	25	D-40113	32	D-45509	130	D-49301	198
D-38510	25	D-40129	32	D-45515	130	D-49317	198
D-38526	25	D-40135	32	D-45521	130	D-49323	198
D-38532	25	D-40141	32	D-45537	130	D-49404	200
D-38548	25	D-40157	32	D-45543	130	D-49410	200
D-38554	25	D-40163	32	D-45559	130	D-49426	200
D-38560	25	D-40179	33	D-45565	130	D-49432	200
D-38576	25	D-40185	33	D-45571	130	D-49448	198
D-38582	25	D-40191	33	D-45587	130	D-49460	198
D-38598	25	D-40705	183	D-45593	130	D-49476	198
D-38607	25	D-41414	182	D-45602	130	D-49482	198
D-38613	25	D-41436	183	D-45618	130	D-49498	200
D-38629	25	D-41442	183	D-45624	130	D-49507	200
D-38635	25	D-41458	178	D-45630	130	D-49513	200
D-38641	25	D-41464	178	D-45646	130	D-49529	198
D-38657	25	D-41838	106	D-45652	130	D-49535	198
D-38663	25	D-41872	33	D-45668	130	D-49541	198
D-38679	25	D-42014	95	D-45674	130	D-49563	198
D-38685	25	D-42531	182	D-45680	130	D-49579	200
D-38691	25	D-42553	183	D-45696	130	D-49694	201
D-38700	25	D-42581	184	D-45705	130	D-49703	201
D-38716	25	D-42678	44	D-45711	130	D-49769	198
D-38722	25	D-42684	44	D-45727	130	D-49775	198
D-38738	25	D-42690	44	D-45733	130	D-49781	198
D-38744	25	D-42709	44	D-45749	130	D-49797	198
D-38934	114	D-42721	44	D-45755	130	D-49806	198
D-38940	114	D-42743	44	D-45761	131	D-49812	198
D-38956	114	D-42793	44	D-45777	131	D-49828	198
D-39752	133	D-42824	44	D-45820	51	D-49840	199
D-39774	133	D-42846	44	D-45836	94	D-49856	199
D-39796	133	D-42874	44	D-47145	96	D-49862	199
D-39811	133	D-44214	119	D-47204	94	D-49878	199
D-39833	133	D-44258	182	D-47248	96	D-49884	199
D-39855	133	D-44264	186	D-49002	197	D-49890	201
D-39877	133	D-44270	180	D-49030	197	D-49943	199
D-39899	133	D-44270-10	180	D-49052	197	D-49965	199
D-39908	130	D-44286	180	D-49068	197	D-49971	199
D-39914	130	D-44286-10	180	D-49074	197	D-50049	201
D-39920	130	D-44292	180	D-49080	197	D-50055	201
D-39936	130	D-44292-10	180	D-49105	197	D-50061	199
D-39942	130	D-44301	185	D-49111	197	D-50077	199
D-39958	130	D-44317	185	D-49127	197	D-50083	199
D-39964	130	D-44323	185	D-49133	197	D-50099	199
D-39970	130	D-44389	181	D-49155	197	D-50158	201
D-39986	130	D-44395	181	D-49177	197	D-50164	201
D-39992	130	D-44404	181	D-49183	200	D-50186	201
D-40004	130	D-44410	181	D-49199	197	D-50217	199
D-40010	130	D-44666	46	D-49208	197	D-50239	202
D-40026	130	D-44672	46	D-49214	197	D-50245	199
D-40032	130	D-44694	46	D-49220	197	D-50251	199
D-40048	32	D-44719	46	D-49236	197	D-50267	199
D-40054	32	D-44731	46	D-49242	197	D-50273	199
D-40060	32	D-44769	110	D-49258	197	D-50289	199
D-40076	32	D-44775	110	D-49264	198	D-50295	199

D-50332	44	D-51633-25	122	D-54449	151	D-56699	148
D-50354	44	D-51649	121	D-54455	151	D-56708	148
D-50360	44	D-51661	121	D-54477	151	D-56714	148
D-50376	44	D-51677	121	D-54483	151	D-56720	148
D-50382	44	D-51683	148	D-54972	65	D-56736	148
D-50398	44	D-51699	148	D-55099	131	D-56742	148
D-50413	44	D-51708	148	D-55108	131	D-56758	148
D-50429	44	D-51714	148	D-55114	131	D-56851	148
D-50435	44	D-51720	148	D-55120	132	D-56873	148
D-50441	44	D-51736	148	D-55136	132	D-56889	148
D-50457	27	D-51742	148	D-55164	131	D-56982	181
D-50479	29	D-51758	148	D-55170	131	D-56998	181
D-50588	40	D-52532	62	D-55186	132	D-57009	181
D-50594	40	D-53051	122	D-55192	132	D-57071	221
D-50603	40	D-53089	122	D-55217	131	D-57087	221
D-50619	40	D-53431	144	D-55223	131	D-57093	40
D-50625	40	D-53447	143	D-55239	132	D-57102	40
D-50631	40	D-53578	203	D-55245	131	D-57118	40
D-50647	40	D-53584	203	D-55251	131	D-57152	160
D-50653	40	D-53637	51	D-55267	131	D-57168	28
D-50669	40	D-53861	154	D-55273	131	D-57174	29
D-50675	40	D-53877	154	D-55289	131	D-57180	29
D-50681	40	D-53883	154	D-55295	132	D-57196	27
D-50697	40	D-53899	154	D-55304	132	D-57205	27
D-50706	40	D-53908	154	D-55310	132	D-57211	38
D-50712	40	D-53914	154	D-55326	132	D-57227	38
D-50728	40	D-53920	154	D-55332	132	D-58497	199
D-50734	40	D-53936	154	D-55348	131	D-58506	199
D-50871	187	D-53942	154	D-55354	131	D-58512	197
D-50887	187	D-53958	154	D-55360	131	D-58528	198
D-50893	186	D-53964	154	D-55376	131	D-58534	198
D-50902	186	D-53970	154	D-55382	131	D-58540	198
D-51085	185	D-53986	154	D-55398	131	D-58556	198
D-51091	185	D-53992	154	D-55407	131	D-58562	198
D-51100	185	D-54003	154	D-55413	131	D-58849	71
D-51188	45	D-54134	150	D-55429	132	D-58861	97
D-51194	45	D-54140	150	D-55435	132	D-58877	95
D-51203	45	D-54156	150	D-55441	132	D-58883	185
D-51219	45	D-54162	150	D-55457	132	D-58899	185
D-51225	45	D-54178	150	D-55463	132	D-58908	185
D-51231	45	D-54184	150	D-55479	132	D-58936	148
D-51247	45	D-54190	150	D-55485	132	D-58942	148
D-51253	45	D-54209	150	D-55491	132	D-58958	148
D-51269	45	D-54215	150	D-56471	140	D-58964	148
D-51281	46	D-54221	151	D-56487	140	D-58970	148
D-51297	46	D-54237	151	D-56493	140	D-58986	148
D-51306	110	D-54243	151	D-56518	38	D-58992	148
D-51312	110	D-54259	151	D-56524	38	D-59003	148
D-51328	110	D-54265	151	D-56530	148	D-59019	148
D-51334	110	D-54271	151	D-56546	148	D-59025	148
D-51340	110	D-54287	151	D-56552	148	D-59031	148
D-51356	110	D-54293	151	D-56568	148	D-59047	148
D-51362	110	D-54302	151	D-56574	148	D-59053	148
D-51378	110	D-54405	151	D-56580	148	D-59069	148
D-51384	110	D-54411	151	D-56596	148	D-59075	148
D-51627-25	122	D-54427	151	D-56677	148	D-59097	110
D-51633	121	D-54433	151	D-56683	148	D-59106	110

ÍNDICE

D-59178	29	D-60698	148	D-62452	110	D-63074	201
D-59184	158	D-60707	148	D-62468	110	D-63080	201
D-59190	158	D-60713	148	D-62474	110	D-63096	201
D-59209	158	D-60729	148	D-62480	110	D-63105	201
D-59215	158	D-60735	148	D-62496	110	D-63111	201
D-59221	158	D-60741	148	D-62505	161	D-63127	201
D-59237	158	D-60757	148	D-62511	161	D-63133	202
D-59243	158	D-60763	148	D-62527	161	D-63149	202
D-59259	158	D-60779	148	D-62533	161	D-63155	202
D-59265	158	D-60785	148	D-62549	161	D-63161	202
D-59271	158	D-60791	148	D-62555	161	D-63177	202
D-59287	158	D-60800	148	D-62561	161	D-63183	202
D-59293	158	D-60816	148	D-62577	161	D-63199	202
D-59302	158	D-60822	148	D-62583	161	D-63208	202
D-59318	158	D-61014	61	D-62599	161	D-63214	202
D-59324	158	D-61210	45	D-62608	161	D-63220	202
D-59330	158	D-61226	45	D-62614	161	D-63236	202
D-59346	160	D-61232	45	D-62620	161	D-63242	202
D-59352	160	D-61248	45	D-62636	161	D-63258	202
D-59368	160	D-61254	45	D-62642	161	D-63432	155
D-59374	160	D-61260	45	D-62658	161	D-63448	155
D-59380	160	D-61276	45	D-62664	161	D-63454	155
D-59396	160	D-61282	45	D-62670	161	D-63460	155
D-59405	160	D-61298	45	D-62739	200	D-63476	155
D-59411	160	D-61307	45	D-62745	200	D-63482	155
D-59427	114	D-61313	45	D-62751	200	D-63498	155
D-60202	26	D-61329	45	D-62767	200	D-63507	155
D-60218	26	D-61335	45	D-62773	200	D-63513	155
D-60224	26	D-61341	45	D-62789	200	D-63529	155
D-60230	26	D-61357	45	D-62795	200	D-63535	155
D-60246	26	D-61363	45	D-62804	200	D-63541	155
D-60252	26	D-61379	45	D-62810	200	D-63666	126
D-60268	26	D-61385	45	D-62826	200	D-63747	154
D-60274	26	D-61391	45	D-62832	200	D-63753	154
D-60280	26	D-61400	45	D-62848	200	D-63769	154
D-60296	26	D-61416	45	D-62854	200	D-63775	154
D-60305	26	D-61422	45	D-62860	200	D-63781	154
D-60311	26	D-61438	45	D-62876	200	D-63797	154
D-60327	26	D-61444	45	D-62882	200	D-63806	154
D-60333	26	D-61450	45	D-62898	200	D-63812	154
D-60349	26	D-61466	112	D-62907	200	D-63828	154
D-60355	26	D-61569	63	D-62913	200	D-63834	154
D-60361	26	D-61575	63	D-62929	200	D-63840	154
D-60377	26	D-61581	64	D-62935	200	D-63856	154
D-60383	26	D-61709	87	D-62941	200	D-63862	97
D-60399	26	D-61868	199	D-62957	200	DA00000169	205
D-60408	26	D-61896	112	D-62963	200	DA00000181	205
D-60414	26	D-61905	112	D-62979	200	DML184	106
D-60420	26	D-62125	110	D-62985	200	DML800	106
D-60436	26	D-62290	178	D-62991	200	DML805	106
D-60442	26	D-62315	178	D-63002	200	DML806	106
D-60458	26	D-62321	178	D-63018	201	DT2010	211
D-60464	26	D-62343	178	D-63024	201	DT4000	211
D-60470	26	D-62359	178	D-63030	201	EB400MP	208
D-60486	26	D-62424	60	D-63046	201	EIB106C	233
D-60676	178	D-62430	60	D-63052	201	GM00001714	106
D-60682	178	D-62446	60	D-63068	201	JM23000065	213

JM23000182	215	P-08850	193	P-33152	149	P-37188	159
JM23300083	233	P-21901	56	P-33168	149	P-37194	159
JM27000500	215	P-21917	56	P-33255	175	P-37203	159
JM274000300	215	P-21923	56	P-33261	175	P-37219	159
JPA122201	192	P-21939	56	P-33277	175	P-37225	159
K000113837	211	P-21945	56	P-33283	175	P-37231	159
K000115180	211	P-21951	56	P-33299	175	P-37247	159
K000117864	211	P-21967	56	P-33308	175	P-37253	159
K000118193	211	P-21973	56	P-33314	175	P-37269	159
K000340781	211	P-31837	149	P-33320	175	P-37275	159
K940019032	211	P-31843	149	P-33336	175	P-37281	159
KIT0001	211	P-31859	149	P-33679	225	P-37297	159
LXLM01	106	P-31865	149	P-33691	225	P-37306	159
LXLM04	106	P-31871	149	P-35807	149	P-37312	159
LXRM01	106	P-31887	149	P-35813	149	P-37328	159
ML100	106	P-31893	149	P-35829	149	P-37334	159
ML102	106	P-31902	149	P-35835	149	P-37340	159
ML103	106	P-31918	152	P-35841	149	P-37356	159
ML104	106	P-31924	152	P-35857	149	P-37362	159
ML120	106	P-31930	152	P-35863	149	P-37378	159
ML140	106	P-31946	152	P-35879	149	P-37471	152
ML143	106	P-31952	152	P-35885	149	P-37487	152
ML187	106	P-31968	152	P-36005	149	P-37493	152
P-00088	157	P-31974	152	P-36011	149	P-37502	152
P-00094	157	P-31980	152	P-36027	149	P-37518	152
P-00103	157	P-31996	152	P-36033	149	P-37524	152
P-00119	157	P-32007	152	P-36049	149	P-37530	152
P-00125	157	P-32013	152	P-36675	157	P-37546	152
P-00131	157	P-32574	152	P-36681	157	P-37552	152
P-00854	153	P-32580	152	P-36697	157	P-37568	151
P-00860	153	P-32596	152	P-36706	157	P-37574	151
P-00876	153	P-32605	152	P-36712	157	P-37580	151
P-00882	153	P-32611	152	P-36728	157	P-37596	151
P-00898	153	P-32633	152	P-36734	157	P-37605	151
P-00907	153	P-32655	152	P-36887	159	P-37611	151
P-00913	153	P-32661	152	P-36893	159	P-37627	151
P-00929	153	P-32677	152	P-36902	159	P-37633	151
P-00935	153	P-32904	149	P-36918	159	P-37649	151
P-00957	153	P-32910	149	P-36924	159	P-37742	151
P-00963	153	P-32926	149	P-36930	159	P-37758	151
P-00979	153	P-32932	149	P-36946	159	P-37764	151
P-00991	153	P-32948	149	P-36952	159	P-37770	151
P-01002	153	P-33009	149	P-36968	159	P-37786	151
P-01018	153	P-33015	149	P-36974	159	P-37792	151
P-01199	157	P-33021	149	P-36980	159	P-37801	151
P-01208	157	P-33037	149	P-36996	159	P-37817	151
P-01214	157	P-33043	150	P-37007	159	P-37823	151
P-01220	157	P-33059	150	P-37013	159	P-37839	151
P-01236	157	P-33065	150	P-37091	158	P-37845	151
P-01395	157	P-33071	150	P-37100	158	P-37851	151
P-01404	157	P-33087	149	P-37116	158	P-37867	151
P-04472	133	P-33093	149	P-37122	158	P-37873	151
P-04488	133	P-33102	149	P-37138	158	P-37889	151
P-04494	133	P-33118	149	P-37144	158	P-37910	151
P-07381	221	P-33124	149	P-37150	158	P-38118	148
P-08838	193	P-33130	149	P-37166	158	P-38124	148
P-08844	193	P-33146	149	P-37172	159	P-38146	148

ÍNDICE

P-39431	157	P-67810	229	T-01943	211	US 11/16"x1"	36
P-39447	157	P-71417	225	T-01959	211	US 11/16"x2"	36
P-39453	157	P-71423	225	T-01965	211	US 13/16"x1"	36
P-39469	157	P-71439	225	T-01971	211	US 13/16"x2"	36
P-39475	157	P-71445	225	T-01993	133	US 15/16"x 1"	36
P-42684	175	P-71451	225	T-02004	133	US 15/16"x 2"	36
P-42690	175	P-71473	225	T-02010	133	US 2"x 1"	36
P-42709	175	P-71489	225	T-02026	133	US 2"x 2"	36
P-42721	175	P-71495	225	T-02375	206	US 3/4"x 1"	36
P-43181	156	P-71504	226	T-02381	206	US 3/4"x 2"	36
P-43197	156	P-71510	226	T-02397	206	US 5/8"x1"	36
P-43206	156	P-71526	226	T-02406	206	US 5/8"x2"	36
P-43212	156	P-71532	226	T-02412	206	US 7/16"x 1"	36
P-43228	156	P-71548	226	T-02428	206	US 7/16"x 2"	36
P-43234	156	P-71554	226	T-02434	206	US 7/8"x 1"	36
P-43240	156	P-71803	229	T-02456	228	US 7/8"x 2"	36
P-43256	157	P-71819	229	T-02462	228	US 9/16"x1"	36
P-43262	157	P-79946	229	T-02515	209	US 9/16"x2"	36
P-43278	157	P-80612	229	T-02521	209	WST05	215
P-43284	157	P-80868	228	T-02543	228	WST06	215
P-43290	157	P-80874	229	T-02559	228		
P-43309	157	P-80880	229	T-02820	89		
P-43315	157	P-80896	229	TR00000002	93		
P-43321	156	P-80905	229	US 1-1/16"x1"	36		
P-43337	156	P-80911	229	US 1-1/16"x2"	36		
P-43343	156	P-80927	229	US 1-1/2"x 1"	36		
P-43359	156	P-80933	228	US 1-1/2"x2"	36		
P-43365	156	P-80949	229	US 1-1/4"x 2"	36		
P-43371	156	P-80955	229	US 1-1/4"x 1"	36		
P-43387	156	P-80961	229	US 1-1/8"x 2"	36		
P-43533	150	P-80977	229	US 1-1/8"x 1"	36		
P-43549	150	P-80999	229	US 1-11/16"x 2"	36		
P-43555	150	P-81000	229	US 1-11/16"x 1"	36		
P-43561	150	P-81337	228	US 1-13/16"x 1"	36		
P-43577	150	P-81343	228	US 1-13/16"x 2"	36		
P-43583	150	P-81371	228	US 1-15/16"x 1"	36		
P-43599	150	P-81474	229	US 1-15/16"x 2"	36		
P-43608	150	P-81480	228	US 1-3/16"x 1"	36		
P-43614	150	Pilo L12L	35	US 1-3/16"x 2"	36		
P-43620	150	Pilot L	35	US 1-3/4"x 2"	36		
P-43636	150	Pilot S	35	US 1-3/4"x 1"	36		
P-43642	150	Pilot S12S	35	US 1-3/8" x 1"	36		
P-43658	150	SC00000111	126	US 1-3/8"x 2"	36		
P-43664	150	SC00000160	126	US 1-5/16"x 2"	36		
P-43670	150	SC09002890	126	US 1-5/16" x 1"	36		
P-43686	150	STEX122385	191	US 1-5/8"x 2"	36		
P-43692	150	STEX122390	192	US 1-5/8"x 1"	36		
P-43701	150	STEXBML360	106	US 1-7/16"x 1 "	36		
P-43804	153	T-01719	89	US 1-7/16"x 2"	36		
P-43810	153	T-01862	211	US 1-7/8"x 2"	36		
P-43826	153	T-01878	211	US 1-7/8"x 1"	36		
P-43832	153	T-01884	211	US 1-9/16"x 1"	36		
P-43848	153	T-01890	211	US 1-9/16"x 2"	36		
P-43854	153	T-01909	211	US 1"x 1"	36		
P-43860	153	T-01915	211	US 1"x 2"	36		
P-43876	153	T-01921	211	US 1/2"x 1"	36		
P-43882	153	T-01937	211	US 1/2"x 2"	36		

Brocas Metal-Madera



118° borde de cincel



135° Punta dividida



HSS-R Alta velocidad
rolada



HSS-G Alta velocidad
fresada



Alta velocidad cobalto 5%



M-force



Titanio alta velocidad



Para martillos SDS-plus



Punta de carburo
de tungsteno



Utilice refrigerante



No perfora con impacto

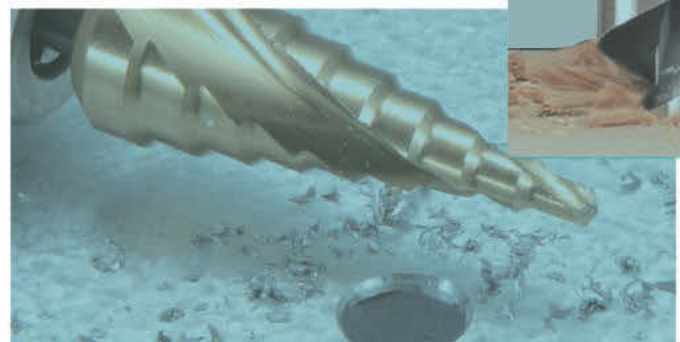
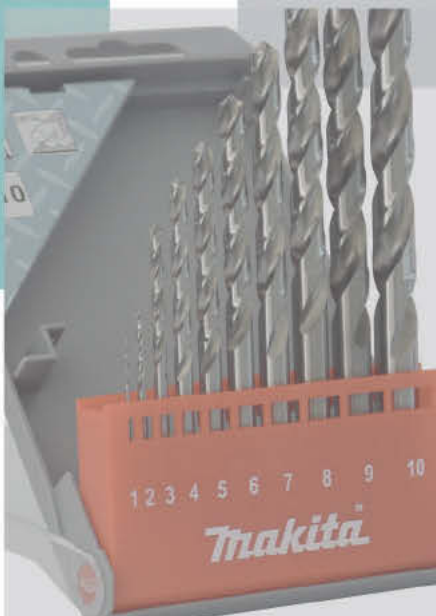

Brocas HSS para Metal

Rango

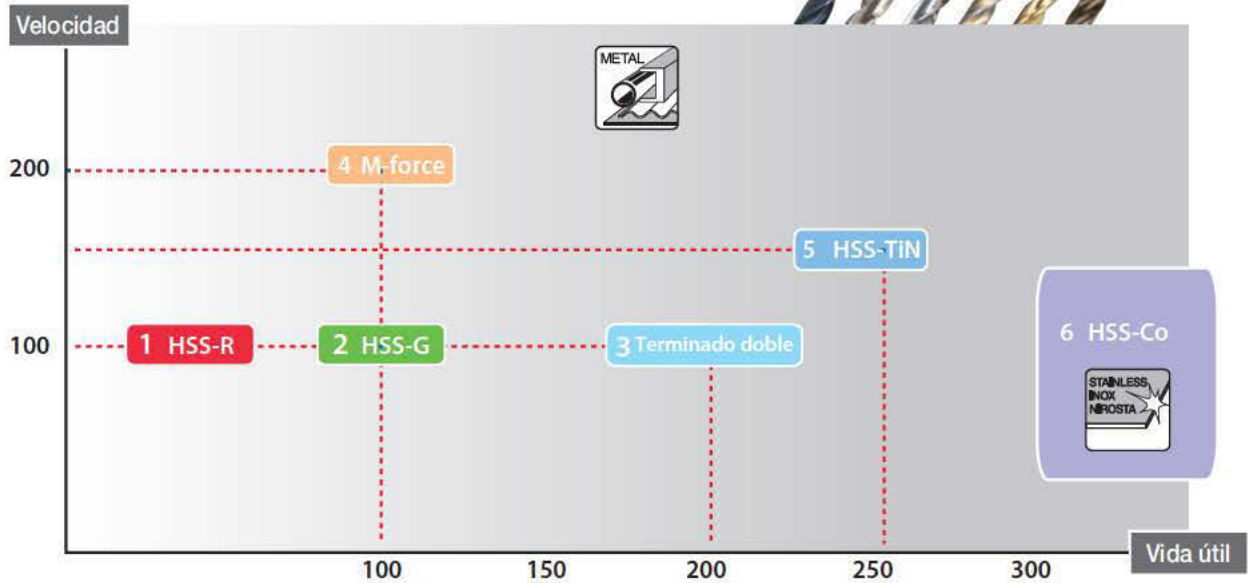

Descripción		A	B	C	D	E
		Hecho de	Proceso de fabricación	Punta geométrica	Superficie	Caña
1	Broca de alta velocidad -R	HSS	Rollo forjado	Chisel plano 118°	Terminado óxido negro	Recto (cilíndrico)
2	Broca para acero de alta velocidad - G	HSS	Fresado	Chisel plano 135°	Terminado brillante	Recto (cilíndrico)
3	Broca terminado doble	HSS	Fresado	Punto 135°	Terminado brillante	Recto (cilíndrico)
4	Punta de metal M-force	HSS	Fresado	Tipo M	Terminado ámbar	Recto (tres planos)
5	HSS-TiN broca de metal	HSS	Fresado	Punto 135°	Titanio cubierta	Recta o 1/4" Hex
6	HSS-Co broca de metal	HSS-Co	Fresado	Punto 135°	Terminado ámbar	Recto (cilíndrico)

Gráfica de material

AA : Recomendado

A : Aceptable

Descripción		Material						
		Madera	Plástico	Metal no ferroso	Chapa de acero	Hierro fundido	Acero aleado	Acero inoxidable
1	Broca de alta velocidad -R	A	AA		A	AA		
2	Broca para acero de alta velocidad - G	A	AA	AA	AA	AA	AA	A
3	Broca terminado doble	A	AA	AA	AA			
4	Punta de metal M-force	A	AA	AA	AA	AA	AA	A
5	HSS-TiN broca de metal	A	AA	AA	AA	AA	AA	A
6	HSS-Co broca de metal			A	A	AA	AA	AA

* Metal no ferroso (como cobre, níquel y zinc)

El equipo estándar (accesorios), las especificaciones y las fotografías pueden variar. Los accesorios pueden no estar incluidos desde origen con las herramientas aunque se indiquen en este catálogo.

Hecho de Acero de alta velocidad



Acero de alta velocidad
(contiene 5% de Cobalto)

Tiene mayor resistencia al calor y abrasión.
Adecuado para taladrar metales duros.

Proceso de fabricación

Rollo forjado



Fabricado con lámina fundida.
El precio es más económico.

Fresado



Broca fresada de larga duración. Para desprender fácilmente el material. La flauta y la punta de la broca permiten remover rápidamente el residuo de material.

Punta geométrica

Cinzel plano



Punto



División geométrica de la punta de 135°, que garantiza la precisión de la perforación.

Tipo M

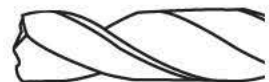

La forma fue diseñada para centrarse en la perforación sin problemas y con rapidez.

Superficie

Terminado brillante



Terminado ámbar



Resistente a la oxidación

Recubrimiento de nitrito de titanio (TiN)



Dura más de 2.5 veces que el tipo de terminado sin revestimiento

Vástago

Recto (cilíndrico)



Recto (tres planos)



El mejor agarre de la empuñadura cilíndrica.

1/4"Hex



Permite un cambio fácil de punta

ACCESORIOS

Broca de alta velocidad-R

Broca de acero de alta velocidad



Diámetro (mm)	Longitud Total	Longitud Trabajo	Empaque Piezas	No. Parte
1	34	12	10	D-38532
1.5	40	18	10	D-38548
2	49	24	10	D-38554
2.5	57	30	10	D-38560
3	61	33	10	D-38576
3.2	65	36	10	D-38582
3.5	70	39	10	D-38598
4	75	43	10	D-38607
4.2	75	43	10	D-38613
4.5	80	47	10	D-38629
4.8	86	52	10	D-38635
5	86	52	10	D-38641
5.5	93	57	10	D-38657
6	93	57	10	D-38663
6.5	101	63	10	D-38679
7	109	69	10	D-38685
7.5	109	69	10	D-38691
8	117	75	10	D-38700
8.5	117	75	10	D-38716
9	125	81	10	D-38722
9.5	125	81	10	D-38738
10	133	87	10	D-38744
11	142	94	1	D-38504
12	151	101	1	D-38510
13	151	101	1	D-38526

Broca de acero de alta velocidad-G

Broca de acero de alta velocidad

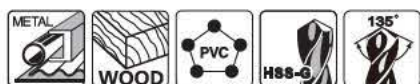

Medida: Pulgadas

** Sin exhibidor

Diámetro	Longitud Total	Longitud Trabajo	Empaque Piezas	No. Parte
1/16"	1-7/8"	7/8"	10	D-21945
5/64"	2"	1"	10	D-21951
3/32"	2-1/4"	1-1/4"	10	D-21967

Brocas metal -madera

Broca de acero de alta velocidad-G

Broca de acero de alta velocidad



Diámetro	Longitud Total	Longitud Trabajo	Empaque Piezas	No. Parte
7/64"	2-5/8"	1-1/2"	10	D-21973
1/8"	2-3/4"	1-5/8"	10	D-21989
9/64"	2-7/8"	1-3/4"	10	D-21995
5/32"	3-1/8"	2"	10	D-22006
11/64"	3-1/4"	2-1/8"	10	D-22012
3/16"	3-1/2"	2-5/16"	10	D-22028
13/64"	3-5/8"	2-7/16"	10	D-22034
7/32"	3-3/4"	2-1/2"	10	D-22040
15/64"	3-7/8"	2-5/8"	10	D-22056
1/4"	4"	2-3/4"	10	D-22062
17/64"	4-1/8"	2-7/8"	10	D-22078
9/32"	4-1/4"	2-15/16"	10	D-22084
19/64"	4-3/8"	3-1/16"	10	D-22096
5/16"	4-1/2"	3-3/16"	10	D-22109
3/8"	5"	3-5/8"	10	D-37219
1/16"	1-7/8"	7/8"	2	D-22230
5/64"	2"	1"	2	D-22246
3/32"	2-1/4"	1-1/4"	2	D-22252
7/64"	2-5/8"	1-1/2"	2	D-22268
1/8"	2-3/4"	1-5/8"	2	D-22274
9/64"	2-7/8"	1-3/4"	2	D-22280
5/32"	3-1/8"	2"	1	D-22296
11/64"	3-1/4"	2-1/8"	1	D-22305
3/16"	3-1/2"	2-5/16"	1	D-22311
13/64"	3-5/8"	2-7/16"	1	D-22327
7/32"	3-3/4"	2-1/2"	1	D-22333
15/64"	3-7/8"	2-5/8"	1	D-22349
1/4"	4"	2-3/4"	1	D-22355
17/64"	4-1/8"	2-7/8"	1	D-22361
9/32"	4-1/4"	2-15/16"	1	D-22377
19/64"	4-3/8"	3-1/16"	1	D-22383
5/16"	4-1/2"	3-3/16"	1	D-22399
21/64"	4-5/8"	3-5/16"	1	D-22408
11/32"	4-3/4"	3-7/16"	1	D-22414
23/64"	4-7/8"	3-1/2"	1	D-22420
3/8"	5"	3-5/8"	1	D-22436
25/64"	5-1/8"	3-3/4"	1	D-22442
13/32"	5-1/4"	3-7/8"	1	D-22458
27/64"	5-3/8"	3-15/16"	1	D-22464
7/16"	5-1/2"	4-1/16"	1	D-22470
29/64"	5-5/8"	4-3/16"	1	D-22486
15/32"	5-3/4"	4-5/16"	1	D-22492
31/64"	5-7/8"	4-3/8"	1	D-22501
1/2"	6"	4-1/2"	1	D-22517
Varias Medidas			200	D-30601**
Varias Medidas			600	D-29907

El equipo estándar (accesorios), las especificaciones y las fotografías pueden variar. Los accesorios pueden no estar incluidos desde origen con las herramientas aunque se indiquen en este catálogo.

Broca de acero de alta velocidad-G

Titanio

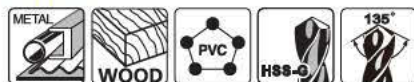

Medida: Pulgadas

Diámetro	Longitud Trabajo	Longitud Total	Empaque Piezas	No. Parte
1/16"	1-7/8"	7/8"	2	D-60202
5/64"	2"	1"	2	D-60218
3/32"	2-1/4"	1-1/4"	2	D-60224
7/64"	2-5/8"	1-1/2"	2	D-60230
1/8"	2-3/4"	1-5/8"	2	D-60246
9/64"	2-7/8"	1-3/4"	2	D-60252
5/32"	3-1/8"	2"	1	D-60268
11/64"	3-1/4"	2-1/8"	1	D-60274
3/16"	3-1/2"	2-5/16"	1	D-60280
13/64"	3-5/8"	2-7/16"	1	D-60296
7/32"	3-3/4"	2-1/2"	1	D-60305
15/64"	3-7/8"	2-5/8"	1	D-60311
1/4"	4"	2-3/4"	1	D-60327
17/64"	4-1/8"	2-7/8"	1	D-60333
9/32"	4-1/4"	2-15/16"	1	D-60349
19/64"	4-3/8"	3-1/16"	1	D-60355
5/16"	4-1/2"	3-3/16"	1	D-60361
21/64"	4-5/8"	3-5/16"	1	D-60377
11/32"	4-3/4"	3-7/16"	1	D-60383
23/64"	4-7/8"	3-1/2"	1	D-60399
3/8"	5"	3-5/8"	1	D-60408
25/64"	5-1/8"	3-3/4"	1	D-60414
13/32"	5-1/4"	3-7/8"	1	D-60420
27/64"	5-3/8"	3-15/16"	1	D-60436
7/16"	5-1/2"	4-1/16"	1	D-60442
29/64"	5-5/8"	4-3/16"	1	D-60458
15/32"	5-3/4"	4-5/16"	1	D-60464
31/64"	5-7/8"	4-3/8"	1	D-60470
1/2"	6"	4-1/2"	1	D-60486

Broca de acero de alta velocidad

Terminado doble



Medida: mm

Diámetro (mm)	Longitud Total (mm)	Longitud Trabajo (mm)	Empaque Piezas	No. Parte
3.1	49	11	10	B-26674
3.2	49	11	10	B-26680
4.1	55	14	10	B-26733
4.2	55	14	10	B-26749
4.8	62	17	10	B-26777
4.9	62	17	10	B-26783
5.5	66	19	10	B-26820
6	66	19	10	B-26836
8	79	25	10	B-26842
10	89	25	10	B-26858

Broca de acero de alta velocidad

Terminado doble

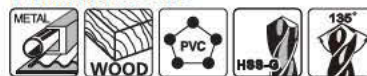

Medida: Pulgadas

Diámetro	Longitud Total	Longitud Trabajo	Empaque Piezas	No. Parte
7/64"	1-7/8"	5/8"	10	B-29907
1/8"	2"	5/8"	10	B-29913
9/64"	2"	5/8"	10	B-29929
5/32"	2-1/16"	5/8"	10	B-29935
3/16"	2-3/16"	5/8"	10	B-29941
7/32"	2-3/8"	11/16"	10	B-29957
1/4"	2-1/2"	7/8"	10	B-29963
#30	2"	5/8"	10	B-29979
#20	2-1/8"	5/8"	10	B-29985
#11	2-1/4"	11/16"	10	B-29991

Brocas SDS PLUS para metal

Para HR166D



Medida: Pulgadas

Tamaño	Longitud total	Zanco Tipo	Empaque Piezas	No. Parte
1/8"	3 - 7/8"	SDS-Plus	1	B-59106
9/64"	4"	SDS-Plus	1	B-59112
5/32"	4 - 1/4"	SDS-Plus	1	B-59128
11/64"	4 - 3/8"	SDS-Plus	1	B-59134
3/16"	4 - 5/8"	SDS-Plus	1	B-59140
13/64"	4 - 3/4"	SDS-Plus	1	B-59156
7/32"	4 - 7/8"	SDS-Plus	1	B-59162
15/64"	5"	SDS-Plus	1	B-59178
1/4"	5 - 3/16"	SDS-Plus	1	B-59184

Juego de brocas de acero de alta velocidad-G

Empaque con 5 Piezas



Medida: mm

Diámetro	Longitud Total	Longitud Trabajo	Empaque Piezas	No. Parte
* Metal 5,6,8mm * Madera 5,6mm	3-7/8", 4", 4-1/2"		5	D-20769

Juego de brocas de acero de alta velocidad-G

Empaque con 5 Piezas



Medida: Pulgadas

Diámetro	Longitud Total	Longitud Trabajo	Empaque Piezas	No. Parte
Metal 3/16, 1/4", 5/16"	3-1/2", 4", 4-1/2"	2-1/16", 2-3/4", 3-3/16"	5	D-30112
Madera 1/4", 5/16"	4", 4-1/2"	2-3/4", 3-3/16"		

Juego de brocas HSS-G para metal



Medidas: mm

Diámetro	Longitud total	Empaque Piezas	No. Parte
2.0mm	24mm	6	D-57196
3.0mm	33mm		
4.0mm	43mm		
5.0mm	52mm		
6.0mm	57mm		
8.0mm	75mm		



Juego de brocas HSS-G para metal



Medidas: mm

Diámetro	Longitud total	Empaque Piezas	No. Parte
1.0mm	12mm	10	D-57205
2.0mm	24mm		
3.0mm	33mm		
4.0mm	43mm		
5.0mm	52mm		
6.0mm	57mm		
7.0mm	69mm		
8.0mm	75mm		
9.0mm	81mm		
10mm	87mm		



Juego de brocas HSS-G para metal

Empaque con 25 Piezas



Medidas: mm

Diámetro						No. parte
1.0mm	3.0mm	5.0mm	7.0mm	9.0mm	11.0mm	D-50457
1.5mm	3.5mm	5.5mm	7.5mm	9.5mm	11.5mm	
2.0mm	4.0mm	6.0mm	8.0mm	10.0mm	12.0mm	
2.5mm	4.5mm	6.5mm	8.5mm	10.5mm	12.5mm	

Set de brocas SDS PLUS para madera y metal

Para HR166D (5 Pzs.)

Contenido	No. Parte
Metal 3/16", 1/4", 5/16" Concreto 3/16", 1/4", 5/16" Madera 3/16", 1/4", 5/16"	B-59243

Set de brocas para acero de alta velocidad TiN con inserción Hex. 1/4"

5 Pz.



Contenido	Zanco Tipo	No. Parte
1/8", 5/32", 3/16", 1/4", 5/16"	Hexagonal 1/4"	D-35318

Broca para acero de alta velocidad TiN con inserción Hex. 1/4"

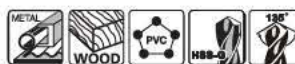

Medida: Pulgadas

Diámetro	Longitud	Longitud Trabajo	Zanco Tipo	Empaque Piezas	No. Parte
7/64"	3-15/32"	1-1/2"	MZ	1	D-23874
1/8"	3-15/32"	1-5/8"	MZ	1	D-23880
9/64"	3-1/2"	1-3/4"	MZ	1	D-23896
5/32"	3-13/16"	2"	MZ	1	D-23905
3/16"	4-7/32"	2-5/16"	MZ	1	D-23911
1/4"	4-3/4"	2-3/4"	MZ	1	D-23927
5/16"	4-1/2"	3-3/16"	MZ	1	D-23933
3/8"	5"	3-5/8"	MZ	1	D-23949

El equipo estándar (accesorios), las especificaciones y las fotografías pueden variar. Los accesorios pueden no estar incluidos desde origen con las herramientas aunque se indiquen en este catálogo.

Juego combinado de brocas Concreto, madera y metal

Paquete de brocas con inserción Hex. 1/4"

Diámetro	No. Parte
Concreto: 3/16", 1/4" madera - metal: 1/8", 3/16", 1/4"	D-23765



Brocas para acero de alta velocidad HSS-Co(cobalto 5%)

Brocas de acero de alta velocidad

Medida: Pulgadas



Diámetro	Longitud Total	Longitud Trabajo	Empaque Piezas	No. Parte
1/16"	1-7/8"	7/8"	5	D-22816
5/64"	2"	1"	5	D-22822
3/32"	2-1/4"	1-1/4"	5	D-22838
7/64"	2-5/8"	1-1/2"	5	D-22844
1/8"	2-3/4"	1-5/8"	5	D-22850
9/64"	2-7/8"	1-3/4"	5	D-22866
5/32"	3-1/8"	2"	5	D-22872
11/64"	3-1/4"	2-1/8"	5	D-22888
3/16"	3-1/2"	2-5/16"	5	D-22894
13/64"	3-5/8"	2-7/16"	5	D-22903
7/32"	3-3/4"	2-1/2"	5	D-22919
15/64"	3-7/8"	2-5/8"	5	D-22925
1/4"	4"	2-3/4"	5	D-22931
17/64"	4-1/8"	2-7/8"	5	D-22947
9/32"	4-1/4"	2-15/16"	5	D-22953
19/64"	4-3/8"	3-1/16"	5	D-22969
5/16"	4-1/2"	3-3/16"	5	D-22975
21/64"	4-5/8"	3-5/16"	5	D-22981
11/32"	4-3/4"	3-7/16"	5	D-22997
23/64"	4-7/8"	3-1/2"	5	D-23008
3/8"	5"	3-5/8"	5	D-23014
25/64"	5-1/8"	3-3/4"	5	D-23020
13/32"	5-1/4"	3-7/8"	5	D-23036
27/64"	5-3/8"	3-15/16"	5	D-23042
7/16"	5-1/2"	4-1/16"	5	D-23058
29/64"	5-5/8"	4-3/16"	5	D-23064
15/32"	5-3/4"	4-5/16"	5	D-23070
31/64"	5-7/8"	4-3/8"	5	D-23086
1/2"	6"	4-1/2"	5	D-23092
1/16"	1-7/8"	7/8"	2	D-22523
5/64"	2"	1"	2	D-22539
3/32"	2-1/4"	1-1/4"	2	D-22545
7/64"	2-5/8"	1-1/2"	2	D-22551

Brocas para acero de alta velocidad HSS-Co (cobalto 5%)

Brocas de acero de alta velocidad



Medida: Pulgadas

Diámetro	Longitud Total	Longitud Trabajo	Empaque Piezas	No. Parte
1/8"	2-3/4"	1-5/8"	2	D-22567
5/32"	3-1/8"	2"	1	D-22589
11/64"	3-1/4"	2-1/8"	1	D-22595
3/16"	3-1/2"	2-5/16"	1	D-22604
13/64"	3-5/8"	2-7/16"	1	D-22610
7/32"	3-3/4"	2-1/2"	1	D-22626
15/64"	3-7/8"	2-5/8"	1	D-22632
1/4"	4"	2-3/4"	1	D-22648
17/64"	4-1/8"	2-7/8"	1	D-22654
9/32"	4-1/4"	2-15/16"	1	D-22660
19/64"	4-3/8"	3-1/16"	1	D-22676
5/16"	4-1/2"	3-3/16"	1	D-22682
21/64"	4-5/8"	3-5/16"	1	D-22698
11/32"	4-3/4"	3-7/16"	1	D-22707
23/64"	4-7/8"	3-1/2"	1	D-22713
3/8"	5"	3-5/8"	1	D-22729
25/64"	5-1/8"	3-3/4"	1	D-22735
13/32"	5-1/4"	3-7/8"	1	D-22741
27/64"	5-3/8"	3-15/16"	1	D-22757
7/16"	5-1/2"	4-1/16"	1	D-22763
29/64"	5-5/8"	4-3/16"	1	D-22779
15/32"	5-3/4"	4-5/16"	1	D-22785
31/64"	5-7/8"	4-3/8"	1	D-22791
1/2"	6"	4-1/2"	1	D-22800

Juego de brocas HSS-Co Para metal

Empaque con 6 Piezas

No. Parte **D-57168**



Medidas: mm

Diámetro	Longitud total
2.0mm	24mm
3.0mm	33mm
4.0mm	43mm
5.0mm	52mm
6.0mm	57mm
8.0mm	75mm



ACCESORIOS

Juego de brocas HSS-Co Para metal

Empaque con 10 Piezas

No. Parte **D-57174**



Medidas: mm



Diámetro	Longitud total	Diámetro	Longitud total
1.0mm	12mm	6.0mm	57mm
2.0mm	24mm	7.0mm	69mm
3.0mm	33mm	8.0mm	75mm
4.0mm	43mm	9.0mm	81mm
5.0mm	52mm	10mm	87mm

Juego de brocas HSS-Co para metal

Empaque con 13 Piezas

No. Parte **D-57180**



Medidas: mm



Diámetro	Longitud total	Diámetro	Longitud total
1.5mm	18mm	4.5mm	47mm
2.0mm	24mm	4.8mm	52mm
2.5mm	30mm	5.0mm	52mm
3.0mm	33mm	5.5mm	57mm
3.2mm	36mm	6.0mm	57mm
3.5mm	39mm	6.5mm	63mm
4.0mm	43mm		

Juego de brocas estándar

Combinado (9 pzs)

No. Parte **D-16449**

Medidas: Pulgadas

Diámetro
Metal 3/16", 1/4", 5/16" Concreto 3/16", 1/4", 5/16" Madera 3/16", 1/4", 5/16"



Brocas metal -madera

Juego de brocas estándar

Combinado (18 pzs)

No. Parte **D-59178**

Diámetro
1/8", 5/32", 3/16", 1/4", 5/16", 3/8" Metal, concreto, madera



Juego de brocas HSS-Co para acero inoxidable

Empaque con 25 Piezas

No. Parte **D-50479**



Medidas: mm

Diámetro						
1.0mm	3.0mm	5.0mm	7.0mm	9.0mm	11.0mm	13.0mm
1.5mm	3.5mm	5.5mm	7.5mm	9.5mm	11.5mm	
2.0mm	4.0mm	6.0mm	8.0mm	10.0mm	12.0mm	
2.5mm	4.5mm	6.5mm	8.5mm	10.5mm	12.5mm	



Base para taladro

No. Parte **A-36712**

Usar en	Aplicación
Taladros 3/8" y 1/2"	Permite utilizar un taladro convencional a modo de taladro de banco



Aceite micro oleo en aerosol

No. Parte **0042010**

Aplicación
Lubricación entre broca y metal para evitar sobrecalentamientos





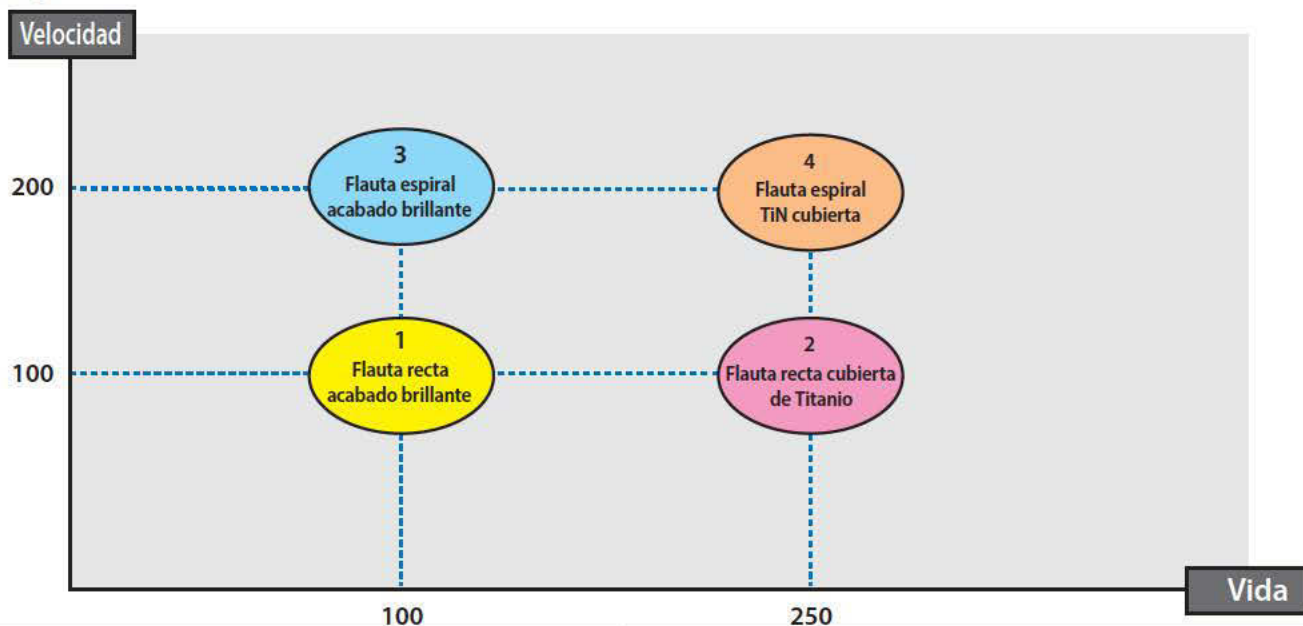

El equipo estándar (accesorios), las especificaciones y las fotografías pueden variar. Los accesorios pueden no estar incluidos desde origen con las herramientas aunque se indiquen en este catálogo.

Brocas escalonadas

Rango



Descripción	A	B	C
	Flauta	Superficie	Vástago
1 	Recta	Terminado brillante	Tres planos o 1/4" Hex
2 	Recta	Recubrimiento de titanio	Tres planos o 1/4" Hex
3 	Espiral	Terminado brillante	Tres planos o 1/4" Hex
4 	Espiral	Recubrimiento de titanio	Tres planos o 1/4" Hex

Gráfica de material

AA : Recomendado

A : Aceptable

Descripción	Material				
	Plástico	Metal no ferroso (como el cobre, níquel y zinc)	Chapa de acero	Acero aleado	Hierro fundido
1 Flauta recta	AA	AA	AA	A	A
2 Flauta recta recubrimiento de titanio	AA	AA	AA	A	A
3 Flauta espiral	AA	AA	AA	A	A
4 Flauta espiral recubrimiento de titanio	AA	AA	AA	A	A

Metal no ferroso (como el cobre, níquel y zinc)



BROCA ESCALONADA

Flauta

Flauta recta



Flauta espiral

Dos veces más rápida que la flauta recta



Superficie

Terminado brillante



Recubrimiento de nitrito de titanio (TiN)

Dura más de 2.5 veces que el tipo de acabado brillante



Vástago

Recto (tres planos)

El mejor agarre de la empuñadura cilíndrica



1/4" Hex (forma E)

Puede ser utilizado con porta punta de 1/4"

Permite un cambio fácil de punta



Broca cónica



Diámetro (mm)	Longitud total (mm)	Longitud trabajo (mm)	Zanco tipo	Empaque Piezas	No. Parte
3-14	58	38	Recto (tres planos)	1	D-40048
4-20	71	51	Recto (tres planos)	1	D-40054

Broca cónica



Diámetro (mm)	Longitud total (mm)	Longitud trabajo (mm)	Zanco tipo	Empaque Piezas	No. Parte
16-30.5	76	51	Recto (tres planos)	1	D-40060
24-40	89	64	Recto (tres planos)	1	D-40076

Brocas escalonadas rectas HSS-milimétricas



Diámetro (mm)	Longitud total (mm)	Longitud trabajo (mm)	Zanco tipo	Empaque Piezas	No. Parte
4-12	65	45	1/4" Hex. (MZ)	1	D-40082
4-20	75	53	1/4" Hex. (MZ)	1	D-40098
4-32	102	80	Recto (tres planos)	1	D-40107

Broca escalonada recta Hss-Ti-milimétricas

Cubierta de titanio



Diámetro (mm)	Longitud total (mm)	Longitud trabajo (mm)	Zanco tipo	Empaque Piezas	No. Parte
4-12	65	45	1/4" Hex. (MZ)	1	D-40113
4-20	75	53	1/4" Hex. (MZ)	1	D-40129
4-32	102	80	Recto (tres planos)	1	D-40135

Brocas escalonadas espirales HSS-milimétricas



Diseñadas para perforar agujeros en chapa metálica

Con revestimiento de Estaño



Vástago 1/4" Hex.

Adecuado para la expansión de los agujeros existentes

Hecha de acero de alta velocidad HSS

Ver video



Diámetro (mm)	Longitud total (mm)	Longitud trabajo (mm)	Zanco tipo	Empaque Piezas	No. Parte
4-12	65	45	1/4" Hex. (MZ)	1	D-40141
4-20	75	53	1/4" Hex. (MZ)	1	D-40157
4-32	102	80	Recto (tres planos)	1	D-40163



Brocas escalonadas espirales HSS-Ti-milimétricas Titanio



DIN 1412C

Con cobertura de Nitruro de titanio TiN

Diseñadas para perforar agujeros en chapa metálica
Hecha de acero de alta velocidad HSS

Vástago 1/4" Hex.



Adecuado para la expansión de los agujeros existentes

[Ver video](#)

Diámetro (mm)	Longitud total (mm)	Longitud trabajo (mm)	Zanco tipo	Empaque Piezas	No. Parte
4-12	65	45	1/4" Hex. (MZ)	1	D-40179
4-20	75	53	1/4" Hex. (MZ)	1	D-40185
4-32	102	80	Recto (tres planos)	1	D-40191

Brocas escalonadas rectas HSS-Ti Titanio



Medida: Pulgadas

Diámetro	Longitud total (mm)	Longitud trabajo (mm)	Zanco tipo	Empaque Piezas	No. Parte
1/8"-1/2"	3-9/32"	2-1/2"	1/4" Hex. (MZ)	1	B-31011
3/16"-1/2"	3-9/32"	2-1/2"	1/4" Hex. (MZ)	1	B-31027
3/16"-7/8"	3"	2"	Recto (tres planos)	1	B-31033
1/4"-3/4"	2-5/8"	1-3/4"	Recto (tres planos)	1	B-31049
1/4"-1-3/8"	3"	2-1/8"	Recto (tres planos)	1	B-31055

Brocas escalonadas rectas Titanio



Medida: Pulgadas

Diámetro	Longitud total (mm)	Longitud trabajo (mm)	Zanco tipo	Empaque Piezas	No. Parte
7/8"	2-3/16"	1-3/16"	Recto (tres planos)	1	B-31083

Brocas escalonadas rectas HSS-Ti estándar Titanio

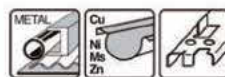

Medida: Pulgadas

Diámetro	Longitud total (mm)	Longitud trabajo (mm)	Zanco tipo	Empaque Piezas	No. Parte
9/16"-1"	2-1/2"	1-1/2"	Recto (tres planos)	1	B-31061
13/16"-1-3/8"	3"	2"	Recto (tres planos)	1	B-31077

Brocas escalonadas espirales rectas HSS-Ti Titanio



Medida: Pulgadas

Diámetro	Longitud total (mm)	Longitud trabajo (mm)	Zanco tipo	Empaque Piezas	No. Parte
1/8"-1/2"	3-9/32"	2-1/2"	1/4" Hex. (MZ)	1	B-31099
3/16"-1/2"	3-9/32"	2-1/2"	1/4" Hex. (MZ)	1	B-31108
3/16"-7/8"	3"	2"	Recto (tres planos)	1	B-31114
1/4"-3/4"	2-5/8"	1-3/4"	Recto (tres planos)	1	B-31120
1/4"-1-3/8"	3"	2-1/8"	Recto (tres planos)	1	B-31136

Brocas escalonadas Titanio (Juego de 3 piezas)



Diámetro (mm)	Longitud total (mm)	Longitud trabajo (mm)	Zanco tipo	Empaque Piezas	No. Parte
4-12	65	45	1/4" Hex. (MZ)	1	D-41872
4-20	75	53	1/4" Hex. (MZ)	1	
4-32	102	80	Recto (tres planos)	1	



















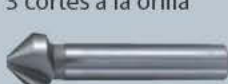

El equipo estándar (accesorios), las especificaciones y las fotografías pueden variar. Los accesorios pueden no estar incluidos desde origen con las herramientas aunque se indiquen en este catálogo.

TIPOS DE AVELLANADORES



Gráfica de material

AA: Recomendado A: Aceptable

Descripción	A	B	C	Material					
	Hecho de	Tipo	Vastago	Madera	Plástico	*Metal no ferroso	Hierro fundido	Acero aleado	Acero inoxidable
7 cortes a la orilla 			 1/4"Hex	AA	AA	AA	A		
3 cortes a la orilla 			 1/4"Hex (forma C)	AA	AA	AA	A	AA	
5 cortes a la orilla 			 Zanco recto	AA	AA	AA	A	AA	
3 cortes a la orilla 			 Zanco recto	AA	AA	AA	A	AA	
Inclinación de la perforación 			 Zanco recto		AA	AA	A	AA	A

A Hecho de

Acero de alta velocidad



Acero de alta velocidad (contiene 5% de cobalto)



Acero de alta velocidad



Tiene mayor resistencia al calor y abrasión. Adecuado para taladrar metales duros.

B Tipo

* Metal no ferroso (como el cobre, níquel y zinc)

Hundimiento superficial



Apto para avellanado superficial

Hundimiento superficial



Apto para profundidad de avellanado. Especialmente en hojas delgadas de metal.

Profundidad



Apto para profundidad de avellanado.

ACCESORIOS

Brocas metal -madera

Avellanadores HSS zanco recto

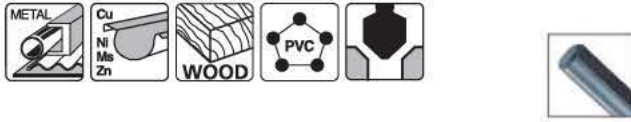

Medida: Pulgadas

Diámetro	Longitud total	Empaque Piezas	Aplicación	No. Parte
1/2"	1-5/8"	1	-	B-30003
5/8"	1-3/4"	1	-	B-30019
3/4"	1-3/4"	1	-	B-30025

Avellanador cinco filos con 82°

Punta cortante

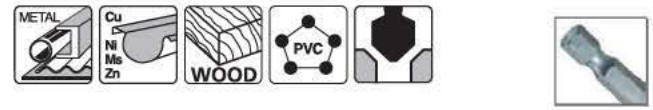

Medida: Pulgadas

Diámetro	Longitud total	Empaque Piezas	Aplicación	Zanco	No. Parte
1/2"	2"	1	-	1/4" Hex	B-30069
5/8"	2"	1	-	1/4" Hex	B-30075
3/4"	2"	1	-	1/4" Hex	B-30081

Avellanador cubierta de titanio con 82°

Punta cortante

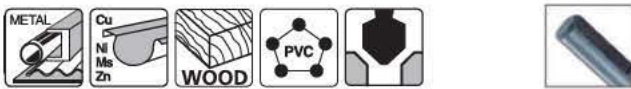

Medida: Pulgadas

Diámetro	Longitud total	Empaque Piezas	Aplicación	No. Parte
1/2"	1-5/8"	1	-	B-30031
5/8"	1-3/4"	1	-	B-30047
3/4"	1-3/4"	1	-	B-30053

Pilotos y adaptadores



Descripción	Unidad	No. Parte
Piloto centrado 1"	1	Pilot S
Piloto centrado 2"	1	Pilot L
Piloto adaptador corto	1	Pilot S12S
Piloto adaptador largo	1	Pilo L12L
Broquero con adaptador	1	Chuc 05

Avellanador cubierta de Titanio con 82°

Punta cortante

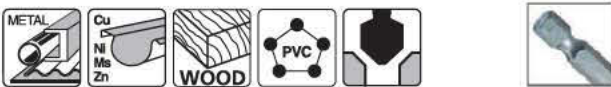

Medida: Pulgadas

Diámetro	Longitud total	Empaque Piezas	Aplicación	Zanco	No. Parte
1/2"	1-5/8"	1	-	1/4"	B-30097
5/8"	1-3/4"	1	-	1/4"	B-30106
3/4"	1-3/4"	1	-	1/4"	B-30112



DDF459Z
Taladro- atornillador inalámbrico

El equipo estándar (accesorios), las especificaciones y las fotografías pueden variar. Los accesorios pueden no estar incluidos desde origen con las herramientas aunque se indiquen en este catálogo.

Cortadores anulares

Taladro magnético



Cortadores anulares HSS 1"
Para taladros magnéticos



Cortadores anulares HSS 2"
Para taladros magnéticos

























Diámetro	Longitud	Unidad	No. Parte
7/16"	1"	Pieza	US 7/16"x1"
1/2"	1"	Pieza	US 1/2"x1"
9/16"	1"	Pieza	US 9/16"x1"
5/8"	1"	Pieza	US 5/8"x1"
11/16"	1"	Pieza	US 11/16"x1"
3/4"	1"	Pieza	US 3/4"x1"
13/16"	1"	Pieza	US 13/16"x1"
7/8"	1"	Pieza	US 7/8"x1"
15/16"	1"	Pieza	US 15/16"x1"
1"	1"	Pieza	US 1"x1"
1-1/16"	1"	Pieza	US 1-1/16"x1"
1-1/8"	1"	Pieza	US 1-1/8"x1"
1-3/16"	1"	Pieza	US 1-3/16"x1"
1-1/4"	1"	Pieza	US 1-1/4"x1"
1-5/16"	1"	Pieza	US 1-5/16"x1"
1-3/8"	1"	Pieza	US 1-3/8"x1"
1-7/16"	1"	Pieza	US 1-7/16"x1"
1-1/2"	1"	Pieza	US 1-1/2"x1"
1-9/16"	1"	Pieza	US 1-9/16"x1"
1-5/8"	1"	Pieza	US 1-5/8"x1"
1-11/16"	1"	Pieza	US 1-11/16"x1"
1-3/4"	1"	Pieza	US 1-3/4"x1"
1-13/16"	1"	Pieza	US 1-13/16"x1"
1-7/8"	1"	Pieza	US 1-7/8"x1"
1-15/16"	1"	Pieza	US 1-15/16"x1"
2"	1"	Pieza	US 2"x1"

Diámetro	Longitud	Unidad	No. Parte
7/16"	2"	Pieza	US 7/16"x2"
1/2"	2"	Pieza	US 1/2"x2"
9/16"	2"	Pieza	US 9/16"x2"
5/8"	2"	Pieza	US 5/8"x2"
11/16"	2"	Pieza	US 11/16"x2"
3/4"	2"	Pieza	US 3/4"x2"
13/16"	2"	Pieza	US 13/16"x2"
7/8"	2"	Pieza	US 7/8"x2"
15/16"	2"	Pieza	US 15/16"x2"
1"	2"	Pieza	US 1"x2"
1-1/16"	2"	Pieza	US 1-1/16"x2"
1-1/8"	2"	Pieza	US 1-1/8"x2"
1-3/16"	2"	Pieza	US 1-3/16"x2"
1-1/4"	2"	Pieza	US 1-1/4"x2"
1-5/16"	2"	Pieza	US 1-5/16"x2"
1-3/8"	2"	Pieza	US 1-3/8"x2"
1-7/16"	2"	Pieza	US 1-7/16"x2"
1-1/2"	2"	Pieza	US 1-1/2"x2"
1-9/16"	2"	Pieza	US 1-9/16"x2"
1-5/8"	2"	Pieza	US 1-5/8"x2"
1-11/16"	2"	Pieza	US 1-11/16"x2"
1-3/4"	2"	Pieza	US 1-3/4"x2"
1-13/16"	2"	Pieza	US 1-13/16"x2"
1-7/8"	2"	Pieza	US 1-7/8"x2"
1-15/16"	2"	Pieza	US 1-15/16"x2"
2"	2"	Pieza	US 2"x2"

Brocas para madera



Descripción	A	B	C
	Punta	Zanco	Diámetro
Broca manita  <p>Adecuado para perforaciones de diámetro mediano y grande en madera suave o plástico blando. No es tan exacto como la broca para madera pero es razonable.</p>	Punta brad 	Recto 	6 - 36mm 1/4" - 1-1/2"
		1/4" Hex 	1/4" - 1-1/4"
Broca para madera  <p>Esta es la Broca más popular en perforación para madera de diámetro pequeño a mediano. Capaz de perforar diversos plásticos blandos y madera en general.</p>	Punta brad 	Recto 	3 - 20mm 1/8" - 3/4"
		1/4" Hex 	3 - 15mm
Broca auger tipo berbiquí  <p>Adecuado para perforaciones profundas con diámetros medianos y grandes. La parte superior en forma de berbiquí requiere muy poca presión. Comparado con la punta plana o broca para madera, cortando la superficie suavemente.</p>	Cuerda auger 	Recto 	6 - 30mm 1/4" - 1-1/4"
		1/4" Hex 	6 - 21mm
Broca auger tipo berbiquí  <p>Adecuado para perforar madera con clavos que no pueden perforar con un solo mástil. Por ejemplo en materiales de construcción y vigas de madera.</p>	Cuerda auger 	5/16" 7/16" Hex 	10 - 38mm 3/8" - 1-1/2"
		7/16" Hex 	1" - 3"
Broca de corona  <p>Adecuado para perforaciones de gran diámetro en madera. La parte superior es de tipo auger y requiere muy poca presión. Especial para tablaroca.</p>	Cuerda auger 	7/16" Hex 	1" - 3"
Broca forstner  <p>Es adecuado para la perforación ciega o penetrante de diámetro de tamaño mediano a grande con alta calidad, por ejemplo: Cocinas integrales en bisagras bidimensionales</p>	Broca Brad (Corta) 	Recto 	10 - 50mm 1/4" - 2 - 1/8"

El equipo estándar (accesorios), las especificaciones y las fotografías pueden variar. Los accesorios pueden no estar incluidos desde origen con las herramientas aunque se indiquen en este catálogo.

Broca tipo manita (espada)



Medida: Pulgadas



Diámetro	Longitud total	No. Parte
1/4"	6"	D-24505
5/16"	6"	D-24511
3/8"	6"	D-24527
7/16"	6"	D-24533
1/2"	6"	D-26490
9/16"	6"	D-24549
5/8"	6"	D-24561
11/16"	6"	D-24577
3/4"	6"	D-24583
7/8"	6"	D-24599
15/16"	6"	D-24608
1"	6"	D-24614
1-1/8"	6-1/2"	D-24636
1-1/4"	6-1/2"	D-24658
1-3/8"	6-1/2"	D-24670
1-1/2"	6-1/2"	D-26509

Brocas tipo manita zanco Hex 1/4"



Diámetro	Longitud total	Zanco tipo	Empaque Piezas	Part No.
1/4"	6"	MZ	1	D-23955
3/8"	6"	MZ	1	D-23961
1/2"	6"	MZ	1	D-23977
5/8"	6"	MZ	1	D-23983
3/4"	6"	MZ	1	D-23999
7/8"	6"	MZ	1	D-24000
1"	6"	MZ	1	D-24016
1-1/4"	6"	MZ	1	D-24022



Brocas espirales con punta guía



Medida: Pulgadas

Diámetro	Longitud total	Longitud trabajo	No. Parte
1/8"	2-3/4"	1-5/16"	D-23189
5/32"	3-1/8"	1-3/4"	D-23195
3/16"	3-1/2"	2"	D-23204
1/4"	4"	2-9/16"	D-23210
9/32"	4-1/4"	2-3/4"	D-23226
5/16"	4-1/2"	3"	D-23232
11/32"	4-3/4"	3"	D-23248
3/8"	5-1/8"	3-11/32"	D-23254
7/16"	5-5/8"	3-3/4"	D-23260
1/2"	6-5/8"	3-3/4"	D-23276
5/8"	7"	4-3/4"	D-23282
11/16"	8"	5-7/8"	D-23298
3/4"	8"	5-7/8"	D-23307

Juego de brocas espirales con punta guía



Piezas	No. Parte
5 (3, 5, 6, 7, 8mm)	D-57211
8 (3, 4, 5, 6, 7, 8, 9, 10mm)	D-57227



Brocas autoalimentables para madera

Broca corona



Diámetro	Zanco	No. Parte
1"	HEX 7/16"	D-29935
1-1/8"	HEX 7/16"	D-29957
1-1/4"	HEX 7/16"	D-29963
1-3/8"	HEX 7/16"	D-29979
1-1/2"	HEX 7/16"	D-29985
1-3/4"	HEX 7/16"	D-29991
2"	HEX 7/16"	D-30003
2-1/8"	HEX 7/16"	D-30019
2-1/4"	HEX 7/16"	D-30025
2-9/16"	HEX 7/16"	D-30031
3"	HEX 7/16"	D-30047
3-5/8"	HEX 7/16"	D-56518
4-5/8"	HEX 7/16"	D-56524

ACCESORIOS

Brocas metal -madera

Brocas auger tipo berbiquí con zanco recto



Medida: Pulgadas

Diámetro	Longitud total	Longitud trabajo	No. Parte
1/4"	8"	5-1/8"	D-23313
5/16"	8"	5-1/8"	D-23329
3/8"	8"	5-1/8"	D-23335
1/2"	8"	5-1/8"	D-23341
9/16"	8"	5-1/8"	D-23357
5/8"	8"	5-1/8"	D-23363
11/16"	8"	5-1/8"	D-23379
3/4"	8"	5-1/8"	D-23385
7/8"	8"	5-1/8"	D-23391
15/16"	8"	5-1/8"	D-23400
1/4"	10"	7"	D-23416
5/16"	10"	7"	D-23422
3/8"	10"	7"	D-23438
1/2"	10"	7"	D-23444
9/16"	10"	7"	D-23450
5/8"	10"	7"	D-23466
11/16"	10"	7"	D-23472
3/4"	10"	7"	D-23488
7/8"	10"	7"	D-23494
15/16"	10"	7"	D-23503
5/16"	16"	13"	D-23519
3/8"	16"	13"	D-23525
1/2"	16"	13"	D-23531
9/16"	16"	13"	D-23547
5/8"	16"	13"	D-23553
11/16"	16"	13"	D-23569
3/4"	16"	13"	D-23575
7/8"	16"	13"	D-23581
15/16"	16"	13"	D-23597
1"	16"	13"	D-23606
1-1/8"	16"	13"	D-23612

Brocas Auger para cuadro 3/4"

Para DTW1001 / perforación de tierra



Medida: Pulgadas

Diámetro	Longitud total	Longitud trabajo	No. Parte
13/16"			B-54302
1"			B-54318
1-3/16"			B-54324
1-3/8"			B-54330

Brocas auger tipo berbiquí zanco 7/16" Hex.

* Zanco Hex 5/16"

Tipo de corte clavo



Medida: Pulgadas

Diámetro	Longitud total	Longitud trabajo	No. Parte
3/8"	6"	3-1/2"	*D-35673
7/16"	6"	3-1/2"	*D-35689
1/2"	6"	3-1/2"	*D-35695
9/16"	6"	3-1/2"	D-35704
5/8"	6"	3-1/2"	D-35710
11/16"	6"	3-1/2"	D-35726
3/4"	6"	3-1/2"	D-35732
13/16"	6"	3-1/2"	D-35748
7/8"	6"	3-1/2"	D-35754
15/16"	6"	3-1/2"	D-35760
1"	6"	3-1/2"	D-35776
1-1/16"	6"	3-1/2"	D-35782
1-1/8"	6"	3-1/2"	D-35798
1-1/4"	6"	3-1/2"	D-35807
1-3/8"	6"	3-1/2"	D-35813
1-1/2"	6"	3-1/2"	D-35829
3/8"	18"	15"	D-35835
7/16"	18"	15"	D-35841
1/2"	18"	15"	D-35857
9/16"	18"	15"	D-35863
5/8"	18"	15"	D-35879
11/16"	18"	15"	D-35885
3/4"	18"	15"	D-35891
13/16"	18"	15"	D-35900
7/8"	18"	15"	D-35916
15/16"	18"	15"	D-35922
1"	18"	15"	D-35938
1-1/16"	18"	15"	D-35944
1-1/8"	18"	15"	D-35950
1-1/4"	18"	15"	D-35966
1-3/8"	18"	15"	D-35972
1-1/2"	18"	15"	D-35988

Brocas SDS PLUS para madera

Para HR166D



Medida: Pulgadas

Tamaño	Longitud total	Zanco Tipo	Empaque Piezas	No. Parte
5/32"	4 - 1/8"	SDS- Plus	1	B-59190
3/16"	4 - 5/8"	SDS- Plus	1	B-59209
1/4"	5 - 1/8"	SDS- Plus	1	B-59215
5/16"	5 - 3/4"	SDS- Plus	1	B-59221
3/8"	6 - 3/8"	SDS- Plus	1	B-59237

El equipo estándar (accesorios), las especificaciones y las fotografías pueden variar. Los accesorios pueden no estar incluidos desde origen con las herramientas aunque se indiquen en este catálogo.

Brocas forstner

Ideales para bisagras bidimensionales
En cocinas integrales



Diseño de los dientes para alta precisión

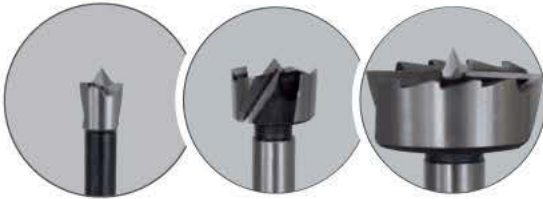

Ideal para:

MADERA

AGLOMERADOS



D-50588

Cortadores precisos para perforaciones limpias



Ver video

Medida: Pulgadas

Diámetro	Vástago	Longitud trabajo	No. Parte
1/4"	3/8"	3-1/8"	U-50588
3/8"	3/8"	3-1/8"	U-50594
1/2"	3/8"	3-1/8"	U-50603
5/8"	3/8"	3-1/8"	U-50619
3/4"	3/8"	3-1/8"	U-50625
7/8"	3/8"	3-1/8"	U-50631
1"	3/8"	3-1/8"	D-50647
1 1/8"	3/8"	3-1/8"	D-50653
1 1/4"	3/8"	3-1/8"	D-50669
1 3/8"	3/8"	3-1/8"	D-50675
1 1/2"	3/8"	3-1/8"	D-50681
1 5/8"	3/8"	3-1/8"	D-50697
1 3/4"	3/8"	3-1/8"	D-50706
1 7/8"	3/8"	3-1/8"	D-50712
2"	3/8"	3-1/8"	D-50728
2 1/8"	3/8"	3-1/8"	D-50734

Corta círculos ajustable



Medida: Pulgadas

Diámetro	Vástago	No. Parte
30-120mm	3/8"	D-57093
30-200mm	3/8"	D-57102
Repuesto de corta círculos (2 piezas)		D-57118

Brocas de avellanado para Madera Juego de avellanadora

Brocas más llave hexagonal

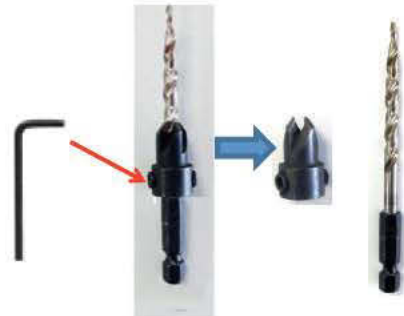

Dimensiones	Longitud	Empaque Piezas	Aplicación	No. Parte
9/64"	#6	3 llave Hex.		
11/64"	#8			A-99661
3/16"	#10			
9/64"	#6	1 / llave Hex.		A-99677
11/64"	#8	1 / llave Hex.		A-99683
3/16"	#10	1 / llave Hex.		A-99699
7/32"	#12	1 / llave Hex.		A-99708
9/64"	#6	1	Repuesto	A-99714
11/64"	#8	1	Repuesto	A-99720
3/16"	#10	1	Repuesto	A-99736
7/32"	#12	1	Repuesto	A-99742



BROCASIERRAS

Ezychange BiM



BiM perforación



BiM hoja de metal



Multi propósito dientes de carburo



TCT Perforación Grano de carburo de tungsteno



Brocasiera de diamante electrodepositado



El equipo estándar (accesorios), las especificaciones y las fotografías pueden variar. Los accesorios pueden no estar incluidos desde origen con las herramientas aunque se indiquen en este catálogo.

























BROCASIERRAS

Gráfica de material

AA :Recomendable

A :Aceptable

Aplicación	Metal	Acero inoxidable	Aluminio	ferrosos	Madera	MDF	Tabla roca	PVC	Fibra de vidrio	Azulejo	Ladrillo	Ladrillo hueco	Mármol	Granito	Vidrio	Cerámica
																
 Ezychange	AA	A	AA	AA	A			AA								
 Brocasierra bimetalica	AA		A	A	AA			AA								
 Bimetálica Sheet metal	AA	AA	A	A												
 Brocasierra Multipropósito TCT					AA	AA	AA	AA	AA	A	A	AA				
 Brocasierra grano carburo de tungsteno											AA	AA				
 Brocasierra de diamante										AA	AA	AA	AA			
 Brocasierra de diamante electrodepositado										AA			AA	AA	AA	AA
Aplicación / consejos	El uso de corte/aceite	Baja velocidad, utilice cortadora/aceite	El uso de corte/aceite	El uso de corte/aceite									Uso en humedo	Uso en humedo	Uso en humedo	Uso en humedo

ACCESORIOS

Brocasieras "bimetálicas"



Diámetro	No. Parte	Diámetro	No. Parte
5/8", (16mm)	D-21618	3-1/4", (83mm)	D-21777
3/4", (19mm)	D-21624	3-1/2", (89mm)	D-24941
25/32", (20mm)	D-21630	3-5/8", (92mm)	D-21783
7/8", (22mm)	D-21646	4", (102mm)	D-24957
15/16", (24mm)	D-21652	4-1/8", (105mm)	D-21799
1", (25mm)	D-21668	5", (127mm)	D-21808
1-1/8", (29mm)	D-21674	6", (152mm)	D-21814
1-1/4", (32mm)	D-21680		
1-3/8", (35mm)	D-21696		
1-1/2", (38mm)	D-21705		
1-9/16", (40mm)	D-21711		
1-3/4", (44mm)	D-21727		
2", (51mm)	D-21733		
2-1/8", (54mm)	D-24907		
2-1/4", (57mm)	D-21749		
2-1/2", (64mm)	D-24913		
2-11/16", (68mm)	D-21755		
2-3/4", (70mm)	D-24935		
3", (76mm)	D-21761		

Accesorios para brocasieras Bi-metal

Broca piloto



Adaptador



	Aplicación	Se adapta a	No. Parte
Adaptador con broca guía	Para taladros 3/8"	9/16" - 1-1/8"	D-21820
	Para taladros 7/16"	1-1/4" - 6"	D-21836
	Para martillos SDS-Plus	9/16" - 1-1/8"	D-21842
Broca piloto	Longitud 2-3/4"	Todas	D-21864

Brocas metal -madera

Brocasieras "Ezychange" bimetálica cambio fácil

Cambio de piloto y brocasieras sin herramienta (diámetro.14-152mm) en el adaptador Ezychange.



Ezychange

Diámetro	No. Parte	Diámetro	No. Parte
5/8", (16mm)	B-11265	2", (51mm)	B-11405
11/16", (17mm)	B-31706	2-1/16" (52mm)	B-31740
3/4", (19mm)	B-11271	2-1/8", (54mm)	B-18194
25/32", (20mm)	B-11287	2-3/16", (56mm)	B-31756
7/8", (22mm)	B-11293	2-1/4", (57mm)	B-11411
15/16", (24mm)	B-11302	2-3/8", (60mm)	B-11427
1", (25mm)	B-11318	2-1/2", (64mm)	B-11433
1-1/16" (27mm)	B-31712	2-9/16", (65mm)	B-16760
1-1/8", (29mm)	B-11324	2-11/16", (68mm)	B-11449
1-3/16", (30mm)	B-11330	2-3/4", (70mm)	B-11455
1-1/4", (32mm)	B-11346	2-7/8", (73mm)	B-31762
1-3/8", (35mm)	B-11352	3", (76mm)	B-11461
1-7/16", (37mm)	B-31728	3-1/8", (79mm)	B-31778
1-1/2", (38mm)	B-11368	3-1/4", (83mm)	B-11477
1-9/16", (40mm)	B-16754	3-5/8", (92mm)	B-11483
1-5/8", (41mm)	B-11374	4" (102mm)	B-11499
1-3/4", (44mm)	B-11380	4-1/8" (105mm)	B-11508
1-11/16" (46mm)	B-31734	5" (127mm)	B-11514
1-7/8", (48mm)	B-11396	6" (152mm)	B-11520

Para brocasieras "Ezychange Bi Metálica" cambio fácil

Broca piloto



Mandril



Adaptador ezychange de transición



Descripción	No. Parte
Mandril Ezychange con broca HSS-G	B-11536
Broca HSS-G	B-11542
Adaptador Ezychange de transición 14-30mm x 3pcs, por 32-152mm x 3pcs	B-16271

El equipo estándar (accesorios), las especificaciones y las fotografías pueden variar. Los accesorios pueden no estar incluidos desde origen con las herramientas aunque se indiquen en este catálogo.

Brocasieras "Sheet metal"



Diámetro	No. Parte	Diámetro	No. Parte
5/8", (16mm)	B-29670	2", (51mm)	B-29854
11/16", (17mm)	B-29686	2-1/8", (54mm)	B-29860
3/4", (19mm)	B-29692	2-1/4", (57mm)	B-29876
25/32", (20mm)	B-29701	2-3/8", (60mm)	B-29882
13/16", (21mm)	B-29717	2-1/2", (63mm)	B-29898
7/8", (22mm)	B-29723	2-9/16", (64mm)	B-35994
1", (25mm)	B-29739	2-5/8", (67mm)	B-36005
1-1/16", (27mm)	B-29745	2-11/16", (68mm)	B-36011
1-1/8", (29mm)	B-29751	2-3/4", (70mm)	B-36027
1-3/16", (30mm)	B-29767	2-7/8", (73mm)	B-36033
1-1/4", (32mm)	B-29773	3", (76mm)	B-36049
1-5/16", (33mm)	B-29789	3-1/8", (79mm)	B-36055
1-3/8", (35mm)	B-29795	3-1/4", (83mm)	B-36061
1-1/2", (38mm)	B-29804	3-3/8", (86mm)	B-36077
1-9/16", (40mm)	B-29810	3-1/2", (89mm)	B-36083
1-5/8", (41mm)	B-29826	4", (102mm)	B-36099
1-3/4", (44mm)	B-29832	5", (127mm)	B-36108
1-7/8", (48mm)	B-29848	6", (152mm)	B-36114

Accesorios para brocasieras "Sheet metal"

Adaptador para broca piloto HSS



Broca piloto



Aplicación	Se adapta a	No. Parte
------------	-------------	-----------

Adaptador para broca piloto

Para broca 10mm	16 - 35mm	B-36120
Para broca 13mm	38 - 152mm	B-36136

Broca piloto

Largo 60mm	Todas	B-36142
------------	-------	---------

Brocasieras "Multi propósito TCT"



Diámetro	No. Parte	Diámetro	No. Parte
3/4", 19mm	D-42678	1-1/2", 38mm	D-42743
7/8", 22mm	D-42684	2", 51mm	D-42793
1", 25mm	D-42690	2-1/4", 57mm	D-42824
1-1/8", 29mm	D-42709	2-9/16", 65mm	D-42846
1-1/4", 32mm	D-42721	2-11/16", 68mm	D-42874

Accesorios para brocasieras "Multi propósito TCT"

Para broca 13mm



Adaptador SDS Plus



Aplicación	Tipo de Broca Piloto	Se Adapta a	No. Parte
Adaptador para broca piloto			
Para broca 13mm	TCT	22-105mm	D-50332
Para broca 13mm	TCT	19mm	D-50354
Árbol SDS Plus	TCT	19mm	D-50360
Para broca 13mm	HSS	22-105mm	D-50376
Árbol SDS Plus	HSS	22-32mm	D-50382
para broca 13mm	HSS	19mm	D-50398

Broca piloto

8mmx100mm	HSS	22-105mm	D-50413
10x100mm	TCT	22-105mm	D-50429
6.35x90mm	HSS	19mm	D-50435
8x90mm	TCT	19mm	D-50441

ACCESORIOS

Brocasieras "carburo de tungsteno"



Diámetro	No. Parte	Diámetro	No. Parte
1-5/16" (33mm)	D-51188	2-7/8" (73mm)	D-51231
1-3/4" (43mm)	D-51194	3-1/4" (83mm)	D-51247
2-1/8" (53mm)	D-51203	7/16" hex With 90mm broca piloto	D-51253
2-1/2" (63mm)	D-51219	90mm broca piloto	D-51269
2-11/16" (67mm)	D-51225		

Brocasieras "diamante electrodepositado"



Diámetro	No. Parte	Diámetro	No. Parte
5/8" (16mm)	B-45995	2-1/8" (53mm)	B-46084
3/4" (19mm)	B-46006	2-1/4" (57mm)	B-46090
1" (25mm)	B-46012	2-9/16" (64mm)	B-46109
1-3/16" (30mm)	B-46028	Zanco largo 182mm(M12)con broca (Broca centradora)	B-46115
1-1/4" (32mm)	B-46034		B-46121
1-3/8" (35mm)	B-46040	Zanco largo 182mm(M12)	B-46137
1-1/2" (38mm)	B-46056	Zanco largo 182mm SDS-PLUS c/ broca centradora	B-52691
1-3/4" (45mm)	B-46062		
2" (50mm)	B-46078	Zanco largo 182mm SDS-PLUS	B-52700

Juegos de Brocasieras

Medida: Pulgadas

Incluye brocasieras (1 de cada una)	No. Parte
3/4", 7/8", 1-1/8", 1-1/2", 1-3/4", 2-1/4", adaptador A, adaptador B, Resorte de expulsión	D-21870
5/8", 25/32", 1", 1-1/4", 1-9/16", 2", adaptador A, adaptador B, Resorte de expulsión	D-21886
Juego de instalación de cerradura Brocasieras Bi-metal y juego de brocas tipo manita (BIM 2-1/8", adaptador con broca piloto plano (1"x6"))	D-34350

El equipo estándar (accesorios), las especificaciones y las fotografías pueden variar. Los accesorios pueden no estar incluidos desde origen con las herramientas aunque se indiquen en este catálogo.

Brocas metal -madera

Brocasieras "diamante electrodepositado" (segmentado) Corte en Humedo



Para: azulejo, granito, mármol, vidrio

Diámetro	No. Parte	Diámetro	No. Parte
3/4", (19mm)	D-61210	2-1/8", (54mm)	D-61329
25/32", (20mm)	D-61226	2-1/4", (57mm)	D-61335
7/8", (22mm)	D-61232	2-3/8", (60mm)	D-61341
1", (25mm)	D-61248	2-9/16", (64mm)	D-61357
1-1/8", (29mm)	D-61254	2-9/16", (65mm)	D-61363
1-1/4", (32mm)	D-61260	2-5/8", (67mm)	D-61379
1-3/8", (35mm)	D-61276	2-11/16", (68mm)	D-61385
1-1/2", (38mm)	D-61282	2-3/4", (70mm)	D-61391
1-5/8", (41mm)	D-61298	3", (76mm)	D-61400
1-3/4", (44mm)	D-61307	3-1/8", (79mm)	D-61416
2", (51mm)	D-61313	3-1/4", (83mm)	D-61422

Accesorios para brocasieras diamante electrodepositado (segmentado)



Aplicación	Se adapta a	No. Parte
Mandril para brocasieras diamante electrodepositado (segmentado)	19 - 29mm	D-61438
Mandril para brocasieras diamante electrodepositado (segmentado)	32 - 83mm	D-61444
Gula retráctil para brocasieras diamante electrodepositado (segmentado)	-	D-61450

Surtido de brocasieras Bi-Metal



Seis medidas comunes para plomeros y electricistas.

- A: 11mm (*7/16") adaptador con broca piloto
- B: 9.5mm (*3/8") adaptador con broca piloto
- C: Resorte de expulsión

Despachadores



Medida: Pulgadas

Diámetro	Piezas por Empaque	No. Parte
5/8", (16mm)	16	D-44666
3/4", (19mm)	16	D-44672
7/8", (22mm)	14	D-44694
1", (25mm)	12	D-44719
1-1/4", (32mm)	10	D-44731

Surtido de brocasieras multipropósito TCT



D-51297



Surtido de brocasieras Ezychange Bi Metal de cambio fácil



Ezychange

Descripción	No. Parte
3/4", 7/8", 1-1/8", 1-1/2", 1-3/4, 2-1/4", (19, 22, 29, 38, 44, 57mm), adaptador Ezychange, HSS-G taladro de perforación	B-11966
5/8", 25/32", 1", 1-1/4", 1-9/16", 2", (16, 20, 25, 32, 40, 51mm), adaptador Ezychange, HSS-G taladro de perforación	B-11972
25/32", 1", 1-1/4", 1-9/16", 2", 2-9/16", (20, 25, 32, 40, 51, 65mm), adaptador Ezychange, HSS-G taladro de perforación	B-11988
1", 1-1/4", 1-3/16", 2", 2-9/16", 2-11/16", 3", (25, 32, 40, 51, 65, 68, 76mm), adaptador Ezychange, HSS-G taladro de rotación x2	B-18188



D-51281



Descripción	No. Parte
Set de 9 brocasieras multipropósito TCT, con adaptador, broca piloto y maletín 1-1/8"(29mm), 1-3/8"(35mm), 1-1/2"(38mm), 2-1/4"(57mm), 2-1/2"(64mm), 3"(76mm), broca piloto HSS 4", broca piloto TCT 4", adaptador.	D-51281
Set de 9 brocasieras multipropósito TCT, con adaptador, broca piloto y maletín, 7/8"(22mm), 1"(25.4mm), 1-1/8"(29mm), 1-3/8"(35mm), 1-1/2"(38mm), 1-3/4"(45mm), 2"(54mm) broca piloto HSS 4", broca piloto TCT 4", adaptador	D-51297

Brocas Concreto



Corte rápido



Zanco B (ranura)



28.6mm zanco hex
(1-1/8" zanco hex)



Para martillos SDS-MAX



17 mm zanco hex



30mm zanco hex



Para martillos SDS-plus



Para martillos 21mm



Zanco pequeño Makita



13 mm zanco hex



21mm zanco hex





MULTIBROCAS OMNIBOHRER



Punta de carburo con percusión agudizada de mucha resistencia con cabeza reforzada. Puede perforar múltiples materiales sin necesidad de cambiar la broca.



Ideal para **puertas, estantes, marcos de ventanas, etc.**

Diámetro (mm)	Longitud total (mm)	Piezas empaque	No. parte
3/16", 1/4", 5/16", 3/8", 1/2"	3-1/2", 6", 6", 6", 6"	5	D-37029
1/8", 3/16", 1/4", 5/16", 3/8"	3", 3-1/2", 6", 6", 6"	5	D-37100

- Utilice con taladros rotativos de percusión.
- Sin el uso de percusión usar en ladrillos vitrificados, madera o ladrillo común.
- Con el uso de la percusión usar en bloque, piedra, yeso y la mayoría de los grados de concreto.



Brocas multiusos para madera, concreto, plástico, azulejo, aluminio y otros

○ Excelente △ Regular X No Recomendado

(*1) No recomendado para aluminio cuando la punta de Carburo tungsteno esta gastada. Siempre use una broca nueva cuando perforo el aluminio.

MATERIAL	CONCRETO	AZULEJO	LADRILLO	TEJA	PIEDRA CALIZA	MADERA	MADERA Y PLÁSTICO	PLÁSTICO	ALUMINIO	METAL
Figura										
Modo de operación										
Recomendaciones	○	○	○	○	○	○	○	○	○	○

ACCESORIOS

Brocas concreto

Broca para concreto De zanco recto (estándar)

(Broca para mampostería y concreto)



Medida: Pulgadas

Diámetro	Longitud total	Longitud trabajo	No. Parte
1/8"	3"	1-3/4"	D-24309
5/32"	6"	3-9/16"	D-24315
3/16"	3-1/2"	2"	D-24321
3/16"	6"	3-9/16"	D-24337
7/32"	6"	3-9/16"	D-24343
1/4"	4"	2-3/8"	D-24359
1/4"	6"	3-9/16"	D-24365
1/4"	12"	8-7/8"	D-24371
5/16"	6"	3-9/16"	D-24387
5/16"	12"	8-7/8"	D-24393
3/8"	6"	3-9/16"	D-24402
3/8"	12"	8-7/8"	D-24418
7/16"	6"	3-9/16"	D-24424
1/2"	6"	3-3/8"	D-24430
1/2"	12"	8-7/8"	D-24446
5/8"	6"	3-3/8"	D-24452
5/8"	12"	8-7/8"	D-24468
3/4"	12"	8-7/8"	D-24480
1"	12"	8-7/8"	D-24496

Surtido de brocas para concreto

* 5 tamaños diferentes



Medida: Pulgadas

Diámetro	Longitud total	Longitud trabajo	No. Parte
3/16"	3-1/2"	2"	*D-36033
1/4", 5/16" 3/8", 1/2"	6"	3-9/16"	
1/4"	6"	3-9/16"	D-36027

Surtido de brocas para concreto 20 piezas



Medida: Pulgadas

Diámetro	Longitud total	Longitud trabajo	No. Parte
1/4"	6"	3-9/16"	D-24365-20
3/8"	6"	3-9/16"	D-24402-20
1/2"	6"	3-3/8"	D-24430-20

Broca para concreto con inserción Hex 1/4"



Medida: Pulgadas

Diámetro	Longitud total	Longitud trabajo	Zanco tipo	Empaque Piezas	No. Parte
1/8"	3"	1-11/64"	MZ	1	D-24038
3/16"	3-11/32"	1-9/16"	MZ	1	D-24044
1/4"	4"	2-5/32"	MZ	1	D-24050

Omnibohrer

(Broca multi uso)

Broca afilada de alta resistencia con cabeza reforzada para taladro percutor. Perfora diferentes materiales sin necesidad de cambiar la broca, (Ideal para perforar puertas, estantes, marcos de ventanas, etc.)

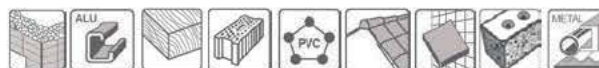

Medida: Pulgadas

Diámetro	Longitud total	Longitud trabajo	No. Parte
1/8"	3"	1-3/8"	D-36859
5/32"	3-1/8"	1-5/8"	D-36865
5/32"	6"	4-3/16"	D-36871
3/16"	3-1/2"	1-3/4"	D-36887
3/16"	6"	4-3/8"	D-36893
1/4"	4"	2-3/16"	D-36902
1/4"	6"	4-3/8"	D-36918
5/16"	4-3/4"	2-7/16"	D-36924
5/16"	6"	4-3/16"	D-36930
3/8"	6"	4-3/16"	D-36946
1/2"	6"	3-5/8"	D-36952

Broca para vidrio



Medida: Pulgadas

Diámetro	Longitud total	No. Parte
1/8"	2-1/2"	D-25183
3/16"	2-1/2"	D-25199
1/4"	3"	D-25208
5/16"	3"	D-25214
3/8"	3-1/8"	D-25220
1/2"	3-1/8"	D-25236

El equipo estándar (accesorios), las especificaciones y las fotografías pueden variar. Los accesorios pueden no estar incluidos desde origen con las herramientas aunque se indiquen en este catálogo.

Juego de 5 brocas Omnibohrer multibroca



Medida: Pulgadas

Diámetro	Longitud total	Longitud trabajo	No. Parte
1/8"	3"	1-3/8"	D-37100
3/16"	3-1/2"	1-3/4"	
1/4"	4"	2-3/16"	
5/16"	6"	4-3/16"	
3/8"	6"	4-3/16"	
3/16"	3-1/2"	1-3/4"	D-37029
1/4"	6"	4-3/8"	
5/16"	6"	4-3/16"	
3/8"	6"	4-3/16"	
1/2"	6"	3-5/8"	

SDS-PLUS "Pro Line"

Perforación en concreto, para uso con martillos rotativos y taladros de percusión con sistema SDS-Plus



Medida: Pulgadas

Diámetro	Longitud total	Longitud trabajo	No. Parte
5/16"	12"	9-1/16"	D-00913
3/8"	6-1/4"	3-5/8"	D-00929
3/8"	12-1/4"	9-1/4"	D-00935
7/16"	6-1/4"	3-5/8"	D-00941
7/16"	12-1/2"	9-1/4"	D-00957
1/2"	6-1/4"	3-3/8"	D-00963
1/2"	12-1/4"	8-7/8"	D-00979
9/16"	6-1/2"	3-3/8"	D-00985
9/16"	12-1/2"	8-7/8"	D-00991
5/8"	8"	4-1/2"	D-01002
5/8"	12"	8-5/8"	D-01018
11/16"	8"	4-5/16"	D-01024
3/4"	8"	4-5/16"	D-01030
3/4"	12"	8-7/16"	D-01046
7/8"	8"	4-5/16"	D-01052
7/8"	12"	8-7/16"	D-01068
1"	10"	6-1/2"	D-01074

SDS-PLUS "Pro Line"

Perforación en concreto, para uso con martillos rotativos y taladros de percusión con sistema SDS-Plus



Medida: Pulgadas

Diámetro	Longitud total	Longitud trabajo	No. Parte
5/32"	4-1/2"	1-5/8"	D-00804
5/32"	6-1/4"	3-5/8"	D-00810
3/16"	4-1/2"	1-5/8"	D-00826
3/16"	6-1/4"	3-5/8"	D-00832
3/16"	8-1/4"	5-1/2"	D-00848
7/32"	6-1/4"	3-5/8"	D-00854
1/4"	4-1/2"	1-5/8"	D-00860
1/4"	6-1/4"	3-5/8"	D-00876
1/4"	8-1/4"	5-1/2"	D-00882
1/4"	11"	8-1/16"	D-00898
5/16"	6-1/4"	3-5/8"	D-00907

SDS-PLUS "Pro line" Paquete de 25 piezas (1 diámetro)



Medida: Pulgadas

Diámetro	Longitud total	Longitud trabajo	No. Parte
5/32"	4-1/2"	1-5/8"	D-00804-25
5/32"	6-1/4"	3-5/8"	D-00810-25
3/16"	4-1/2"	1-5/8"	D-00826-25
3/16"	6-1/4"	3-5/8"	D-00832-25
3/16"	8-1/4"	5-1/2"	D-00848-25
7/32"	6-1/4"	3-5/8"	D-00854-25
1/4"	4-1/2"	1-5/8"	D-00860-25
1/4"	6-1/4"	3-5/8"	D-00876-25
1/4"	8-1/4"	5-1/2"	D-00882-25
1/4"	11"	8-1/16"	D-00898-25
5/16"	6-1/4"	3-5/8"	D-00907-25

ACCESORIOS

Brocas concreto

SDS-PLUS "Pro line" paquete de 25 piezas
(1 diámetro)



Medida: Pulgadas

Diámetro	Longitud total	Longitud trabajo	No. Parte
5/16"	12"	9-1/16"	D-00913-25
3/8"	6-1/4"	3-5/8"	D-00929-25
3/8"	12-1/4"	9-1/4"	D-00935-25
7/16"	6-1/4"	3-5/8"	D-00941-25
7/16"	12-1/4"	9-1/4"	D-00957-25
1/2"	6-1/4"	3-3/8"	D-00963-25
1/2"	12-1/4"	8-7/8"	D-00979-25
9/16"	6-1/4"	3-3/8"	D-00985-25
9/16"	12-1/4"	8-7/8"	D-00991-25
5/8"	8"	4-1/2"	D-01002-25
5/8"	12"	8-5/8"	D-01018-25
11/16"	8"	4-5/16"	D-01024-25
3/4"	8"	4-5/16"	D-01030-25
3/4"	12"	8-7/16"	D-01046-25
7/8"	8"	4-5/16"	D-01052-25
7/8"	12"	8-7/16"	D-01068-25
1"	10"	6-1/2"	D-01074-25

Set de brocas y cinceles SDS-PLUS

Juego de 10 piezas



Medida: Pulgadas

Diámetro	Longitud total	Longitud trabajo	No. Parte
3/16"	6-1/4"	3-5/8"	D-45820
7/32"	6-1/4"	3-5/8"	
1/4"	6-1/4"	3-5/8"	
5/16"	6-1/4"	3-5/8"	
3/8"	6-1/4"	3-5/8"	
7/16"	6-1/4"	3-5/8"	
1/2"	6-1/4"	3-3/8"	
9/16"	6-1/4"	3-3/8"	
Cinzel de 160			
Cinzel de 20x140			

Brocas y cinceles SDS-PLUS

Set de 17 piezas
Estuche textil



Set de brocas SDS-PLUS 5 piezas.

Juego de 5 piezas



Medida Pulgadas

Diámetro	Longitud total	Longitud trabajo	No. Parte
3/16"	4-1/2"	1-5/8"	D-07973
1/4"	6-1/4"	3-5/8"	
5/16"	6-1/4"	3-5/8"	
3/8"	6-1/4"	3-5/8"	
1/2"	6-1/4"	3-3/8"	

Empaque Piezas	Diámetro	Largo	Zanco	No. Parte	
17 piezas	3/16"	4-1/2"	SDS-Plus	D-53637	
	7/32"	6-1/4"	SDS-Plus		
	1/4"	4-1/2"	SDS-Plus		
	1/4"	6-1/4"	SDS-Plus		
	1/4"	8-1/4"	SDS-Plus		
	5/16"	6 1/4"	SDS-Plus		
	5/16"	10"	SDS-Plus		
	3/8"	6-1/4"	SDS-Plus		
	3/8"	10"	SDS-Plus		
	1/2"	6-1/4"	SDS-Plus		
	1/2"	10"	SDS-Plus		
	9/16"	6-1/2"	SDS-Plus		
	Cinzel punta 140				SDS-Plus
	Cinzel punta 250				SDS-Plus
	Cinzel plano 20x250				SDS-Plus
	Cinzel plano 20x140				SDS-Plus
	Cinzel pala 40x250				SDS-Plus

El equipo estándar (accesorios), las especificaciones y las fotografías pueden variar. Los accesorios pueden no estar incluidos desde origen con las herramientas aunque se indiquen en este catálogo.

Brocas y cinceles SDS-PLUS

SDS-Plus con punta de carburo de tungsteno
Maletín
Juego de 13 piezas



Medida: Pulgadas

Empaque Piezas	Diámetro	Longitud total	Longitud trabajo	No. Parte	
13 piezas	5/32"	4-1/2"	1-5/8"	D-31734	
	3/16"	4-1/2"	1-5/8"		
	3/16"	6-1/4"	3-5/8"		
	7/32"	6-1/4"	3-5/8"		
	1/4"	4-1/2"	1-5/8"		
	1/4"	6-1/4"	3-5/8"		
	5/16"	6-1/4"	3-5/8"		
	3/8"	6-1/4"	3-5/8"		
	1/2"	6-1/4"	3-3/8"		
	9/16"	6-1/4"	3-3/8"		
	5/8"	8"	4-1/2"		
	cincel punta 250mm				
	Cincel plano 10x250mm				



Brocas SDS-PLUS TIP

Para martillos con entrada SDS-PLUS

Nuevo empaque retráctil y clip, que protege la broca y evita que se oxide.

Nueva punta que facilita la perforación



Medida: Pulgadas

Diámetro (In)	Longitud total	Empaque Piezas	No. Parte
5/32"	6-1/4"	1	B-61662
3/16"	4-1/2"	1	B-61678
3/16"	6-1/4"	1	B-61684
3/16"	8-1/4"	1	B-61690
3/16"	12"	1	B-61709
7/32"	6-1/4"	1	B-61715
1/4"	4-1/2"	1	B-61721
1/4"	6-1/4"	1	B-61737
1/4"	8-1/4"	1	B-61743
1/4"	11"	1	B-61759
5/16"	6-1/4"	1	B-61765
5/16"	12"	1	B-61771
3/8"	6-1/4"	1	B-61787
3/8"	12-1/4"	1	B-61793
3/8"	18"	1	B-61802
7/16"	12-1/2"	1	B-61818
1/2"	6-1/4"	1	B-61824
1/2"	12-1/4"	1	B-61830
9/16"	6-1/2"	1	B-61846
9/16"	12-1/2"	1	B-61852
5/8"	8"	1	B-61868
5/8"	12"	1	B-61874
3/4"	8"	1	B-61880
3/4"	12"	1	B-61896
7/8"	12"	1	B-61905
7/8"	18"	1	B-61911
1"	10"	1	B-61927
1"	18"	1	B-61933

SDS-PLUS "4 PLUS"



Perforación en concreto para uso con martillos rotativos y taladros de precisión con sistema SDS-Plus

Medida: Pulgadas

Diámetro	Longitud total	Piezas empaque	No. Parte
5/32"	4 1/2"	1	711226-A
5/32"	6 1/4"	1	711227-A
3/16"	4 1/2"	1	711228-A
3/16"	6 1/4"	1	711229-A
3/16"	8 1/4"	1	711230-A
3/16"	10"	1	711231-A
3/16"	12"	1	711232-A
7/32"	6 1/4"	1	711234-A
1/4"	4 1/2"	1	711235-A
1/4"	6 1/4"	1	711236-A
1/4"	8 1/4"	1	711237-A
1/4"	11"	1	711238-A
1/4"	14"	1	711239-A
5/16"	6 1/4"	1	711240-A
5/16"	12"	1	711241-A
3/8"	6 1/4"	1	711242-A
3/8"	12 1/4"	1	711243-A
3/8"	24"	1	711244-A
7/16"	6 1/4"	1	711245-A



Diámetro	Longitud total	Piezas empaque	No. Parte
1/2"	6 1/4"	1	711248-A
1/2"	12 1/4"		711249-A
1/2"	18"	1	711250-A
1/2"	24"		711251-A
9/16"	6 1/2"	1	711252-A
9/16"	12 1/2"		711253-A
5/8"	8"	1	711255-A
5/8"	12"		711256-A
5/8"	18"	1	711257-A
5/8"	24"		711258-A
3/4"	8"	1	711173-A
3/4"	12"		711174-A
3/4"	18"	1	711175-A
7/8"	8"		711176-A
7/8"	12"	1	711177-A
7/8"	18"		711178-A
1"	10"	1	711179-A
1"	18"	1	711180-A

NEMESIS Brocas SDS-PLUS



Resuelve problemas

Ideal para la perforación de concreto armado.
50% superior en el trabajo, más cantidad de perforaciones.

Perforación más precisa

Simetría 4x90°, para perforaciones totalmente circulares y precisas para fijación y anclaje.

La flauta

La cabeza de la broca tiene cuatro salidas para que el polvo se desaloje por las espirales.
Mejor transmisión de la fuerza hacia la punta de la broca y menor vibración.

Punta centrada que facilita la perforación de punto con una precisión milimétrica.

Simetría 4x90° para perforaciones circulares y precisas.

El elevado volumen de flauta geométrica asegura la extracción óptima de polvo en la perforación.

Centro de la flauta optimizado que garantiza un rendimiento de perforación con baja vibración y una resistencia a la fractura.

Cuatro surcos espirales simétricos en funcionamiento que aseguran un desgaste bajo.

El equipo estándar (accesorios), las especificaciones y las fotografías pueden variar.
Los accesorios pueden no estar incluidos desde origen con las herramientas aunque se indiquen en este catálogo.

Brocas SDS-Plus Nemesis



*Brocas SDS-Plus 4 filos.

*Perforación en concreto para uso con martillos rotativos y taladros de percusión con sistema SDS-Plus.



Diámetro (mm)	Longitud total	Empaque Piezas	No. Parte
3/16"	4 1/4"	1	B-17756
3/16"	6 1/4"	1	B-17762
3/16"	8 1/4"	1	B-17778
3/16"	10 1/4"	1	B-17784
1/4"	4 1/4"	1	B-17809
1/4"	6 1/4"	1	B-17815
1/4"	8 1/4"	1	B-17821
1/4"	10 1/4"	1	B-17837
1/4"	12 1/4"	1	B-17843
5/16"	6 1/4"	1	B-17859
5/16"	12 1/4"	1	B-17865
3/8"	6 1/4"	1	B-17887
3/8"	12 1/4"	1	B-17893
3/8"	18"	1	B-17902
7/16"	6 1/4"	1	B-17918
7/16"	12 1/4"	1	B-17924
1/2"	6 1/4"	1	B-17946
1/2"	12 1/4"	1	B-17952
1/2"	18"	1	B-17968
9/16"	6 1/4"	1	B-17974
9/16"	12 1/4"	1	B-17980

Brocas SDS-Max línea estándar

Perforación en concreto para uso con martillos rotativos con sistema SDS-Max



Diámetro (mm)	Longitud total	Longitud trabajo	Empaque Piezas	No. Parte
1/2"	13"	8"	1	D-36538
1/2"	21"	16"	1	D-36544
9/16"	21"	16"	1	D-36550
5/8"	13"	8"	1	D-36566
5/8"	21"	16"	1	D-36572
3/4"	13"	8"	1	D-36588
3/4"	21"	16"	1	D-36594
27/32"	21"	16"	1	D-36603
7/8"	13"	8"	1	D-36619
7/8"	21"	16"	1	D-36625

Brocas SDS-Max línea estándar

Perforación en concreto para uso con martillos rotativos con sistema SDS-Max

Diámetro (mm)	Longitud total	Longitud trabajo	Empaque Piezas	No. Parte
1"	13"	8"	1	D-36631
1"	21"	16"	1	D-36647
1 1/8"	15"	10"	1	D-36653
1 1/8"	22"	18"	1	D-36669
1 1/4"	15"	10"	1	D-36675
1 1/4"	22"	18"	1	D-36681
1 3/8"	22"	18"	1	D-36697
1 1/2"	22"	18"	1	D-36706

Brocas SDS-Max línea profesional

Perforación en concreto para uso con martillos rotativos con sistema SDS-Max



Diámetro (mm)	Longitud total	Longitud trabajo	Empaque Piezas	No. Parte
1/2"	13"	8"	1	711499-A
5/8"	13"	8"	1	711502-A
5/8"	21"	16"	1	711503-A
5/8"	36"	31"	1	711504-A
3/4"	13"	8"	1	711505-A
3/4"	21"	16"	1	B-04684
3/4"	21"	16"	1	711506-A
3/4"	36"	31"	1	711507-A
7/8"	13"	8"	1	711509-A
7/8"	21"	16"	1	711510-A
1"	13"	8"	1	711511-A
1"	21"	16"	1	711512-A
1"	36"	31"	1	B-07406
1"	36"	31"	1	711513-A
1-1/8"	13"	10"	1	B-04737
1 1/8"	17"	12"	1	711514-A
1 1/8"	21"	16"	1	B-04743
1 1/8"	21"	16"	1	711515-A
1 1/4"	23"	18"	1	711517-A
1 1/4"	36"	31"	1	711518-A
1-3/8"	21"	16"	1	B-04765
1 3/8"	23"	18"	1	711519-A
1-7/16"	23"	18"	1	711520-A
1 1/2"	23"	18"	1	B-07428
1 1/2"	23"	18"	1	711521-A



NEMESIS II Brocas SDS-PLUS



Marca de estabilidad

Marca de desgaste que sirve como indicador de la estabilidad de los agujeros. Al desaparecer la marca significa que la broca ha alcanzado su vida útil.

TCT solido grande

Punta de carburo con simetría 4x90°, para corte masivo y simétrico que previene que se atasque.

Su geometría ha sido desarrollada para un máximo impacto y fuerza de torsión, así como una vida útil prolongada.

Innovada geometría de la flauta

En la nueva geometría helicoidal de 4 espirales, se alternan hélices estrechas y anchas. Las estrechas aceleran el avance de la broca para menos fricción y las anchas soportan estructuralmente el martillo reduciendo el desgaste.

El polvo se elimina más rápidamente y garantiza perforaciones de baja vibración y un alto grado de seguridad.



Marca de estabilidad
todos los tamaños de Nemesis II vienen con la marca (5/32" a 1 1/4")



Punta de carburo 4x90°



- 20% más rápida que la Nemesis actual en perforaciones de concreto
- 50% más vida útil en perforación de concreto armado

Flauta

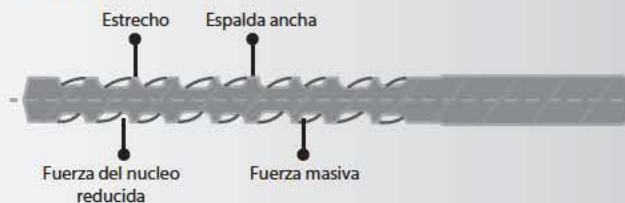

Brocas SDS-Plus Nemesis II

*Perforación en concreto para uso con martillos rotativos SDS-Plus.

Diámetro (mm)	Longitud total	Empaque Piezas	No. Parte
5/32"	4 1/2"	1	B-59330
5/32"	6 1/2"	1	B-59346
3/16"	4 1/2"	1	B-59352
3/16"	6 1/2"	1	B-59368
3/16"	8 1/2"	1	B-59374
3/16"	10 1/2"	1	B-59380
3/16"	12 1/2"	1	B-59396
1/4"	4 1/2"	1	B-59405
1/4"	6 1/2"	1	B-59411
1/4"	8 1/2"	1	B-59427
1/4"	10 1/2"	1	B-59433
1/4"	12 1/2"	1	B-59449
5/16"	6 1/2"	1	B-59455
5/16"	12 1/4"	1	B-59461
5/16"	18"	1	B-59477
3/8"	6 1/4"	1	B-59483
3/8"	12 1/4"	1	B-59499
3/8"	18"	1	B-59508
7/16"	6 1/4"	1	B-59514
7/16"	12 1/4"	1	B-59520
7/16"	18"	1	B-59536
1/2"	6 1/4"	1	B-59542
1/2"	12 1/4"	1	B-59558

Diámetro (mm)	Longitud total	Empaque Piezas	No. Parte
1/2"	18"	1	B-59564
9/16"	6 1/4"	1	B-59570
9/16"	12 1/4"	1	B-59586
9/16"	18"	1	B-59592
5/8"	8 1/4"	1	B-59601
5/8"	10 1/4"	1	B-59617
5/8"	12 1/4"	1	B-59623
5/8"	18"	1	B-59639
3/4"	8"	1	B-59645
3/4"	10"	1	B-59651
3/4"	12"	1	B-59667
3/4"	18"	1	B-59673
7/8"	8"	1	B-59689
7/8"	10"	1	B-59695
7/8"	12"	1	B-59704
7/8"	18"	1	B-59710
1"	10"	1	B-59726
1"	12"	1	B-59732
1"	18"	1	B-59748
1 1/8"	10"	1	B-59754
1 1/8"	18"	1	B-59760
1 1/4"	18"	1	B-59776
3/16" 1/4" 5/16"	6 1/2"	5 (Kit de brocas)	B-59829
3/8" 1/2"	6 1/4"		

El equipo estándar (accesorios), las especificaciones y las fotografías pueden variar. Los accesorios pueden no estar incluidos desde origen con las herramientas aunque se indiquen en este catálogo.

Brocas SDS-MAX (Minería)

Diseñadas para perforación en roca y piedra natural para la exploración y explotación de los siguientes metales, entre otros:



RESISTENTE Y CONFIABLE

Especialmente en piedra natural muestra su alta resistencia. La geometría robusta de la pastilla de carburo de tungsteno esta diseñada para trabajar bajo condiciones extremas. Estas brocas tienen la posibilidad de afilar las pastillas permitiendo una vida más larga ya que pueden perforar 25% o más que las brocas de martillo SDS-MAX estándar.

PASTILLAS LATERALES REFORZADAS



- Las pastillas laterales de carburo de tungsteno apoyan la actividad de la pastilla central.
- Debido al refuerzo que cubre las pastillas laterales, estas son más resistentes.
- Las entradas amplias de los espirales facilitan la evacuación de la roca demolida.



GEOMETRÍA DE LA ESPIRAL

- La espalda expandida de estas brocas las hacen más resistentes, así mismo garantiza la evacuación rápida de polvo de la perforación desde la cabeza a través del espiral.

REFORZAMIENTO DE LA GEOMETRÍA DE LA ESPIRAL

- Debido a este reforzamiento, la broca puede soportar más fuerzas de flexión; lo cual es un desafío en perforaciones bajo condiciones extremas en roca dura.



GEOMETRÍA ROBUSTA DE LA PASTILLA DE CARBURO DE TUNGSTENO

- La pastilla principal de esta broca tiene una geometría muy robusta. Debido a esta característica, la broca es muy resistente y eficiente inclusive en las condiciones más extremas.



Brocas SDS-Max core cutter

Perforación en concreto para diámetros mayores a 1-1/2"
Sistema SDS-Max core cutter



Diámetro (mm)	Longitud total	Empaque piezas	No. Parte
1 3/4"	22"	1	P-21901
1 3/4"	39"	1	P-21917
2 1/8"	22"	1	P-21923
2 1/8"	39"	1	P-21939
2 1/2"	22"	1	P-21945
2 1/2"	39"	1	P-21951
3 1/8"	22"	1	P-21967
3 1/8"	29"	1	P-21973

Broca de carburo de tungsteno SDS-MAX TCT para minería



Medidas: pulgadas

Diámetro	Longitud	Longitud trabajo	Tipo	No. Parte
1-1/8"	27"	22"	Minería	B-15039
1-1/8"	37"	32"	Minería	B-18035
1-1/8"	53"	47"	Minería	B-18041
1-1/4"	23"	18"	Minería	B-14613
1-1/4"	37"	32"	Minería	B-15045
1-1/4"	52"	47"	Minería	B-18057
1-1/2"	15"	9"	Minería	B-18063
1-9/16"	35"	30"	Minería	B-18079
1-1/8"	26"	20"	Minería	B-39431
1-3/16"	28"	23"	Minería	B-39447
1-1/4"	22"	18"	Minería	B-39453
1-1/4"	36"	31"	Minería	B-39469

Set para remover brocas

Use con una llave de impacto para remover broca de SDS Max que se trabó con una varilla en concreto



Destino	No. Parte
Herramienta de utilidad para desatascar brocas, usar con llave de impacto	195871-9

Brocas estriadas (Spline) 2 fillos

Perforación en concreto para uso con martillos rotativos con sistema Spline



*Dos Fillos

Diámetro (mm)	Longitud total	Empaque Piezas	No. Parte
3/8"	10"	1	711191-A
1/2"	10"	1	711192-A
1/2"	16"	1	711193-A
1/2"	22"	1	711194-A
1/2"	29"	1	711195-A
1/2"	36"	1	711196-A
9/16"	10"	1	711197-A
5/8"	10"	1	711198-A
5/8"	16"	1	711199-A
5/8"	22"	1	711200-A
5/8"	29"	1	711201-A
5/8"	36"	1	711202-A
11/16"	16"	1	711203-A
3/4"	10"	1	711204-A
3/4"	16"	1	711205-A
3/4"	22"	1	711206-A
3/4"	29"	1	711207-A
3/4"	36"	1	711208-A
7/8"	16"	1	711209-A
7/8"	22"	1	711210-A
1"	16"	1	711211-A
1"	22"	1	711212-A
1"	29"	1	711213-A
1"	36"	1	711214-A
1 1/8"	16"	1	711215-A
1 1/8"	22"	1	711216-A
1 1/4"	16"	1	711217-A
1 1/4"	22"	1	711218-A
1 1/4"	29"	1	711219-A
1 1/4"	36"	1	711220-A
1 3/8"	16"	1	711221-A
1 1/2"	22"	1	711222-A
1 3/4"	22"	1	711223-A
2"	22"	1	711224-A
22mm	525mm	1	791134-7
25.5mm	525mm	1	791135-5
20mm	525mm	1	791024-4

Brocas estriadas (Spline) 4 fillos

Perforación en concreto con martillos rotativos con Sistema Spline



Diámetro (mm)	Longitud total	Empaque piezas	No. Parte
5/8"	10"	1	711430-A
5/8"	16"	1	711431-A
5/8"	22"	1	711432-A
5/8"	29"	1	711433-A
5/8"	36"	1	711434-A
3/4"	10"	1	711435-A
3/4"	16"	1	711436-A
3/4"	22"	1	711437-A
3/4"	29"	1	711438-A
3/4"	36"	1	711439-A
7/8"	16"	1	711440-A
7/8"	22"	1	711441-A
1"	16"	1	711442-A
1"	22"	1	711443-A
1"	29"	1	711444-A
1"	36"	1	711445-A
1 1/8"	16"	1	711446-A
1 1/8"	22"	1	711447-A
1 1/4"	16"	1	711448-A
1 1/4"	22"	1	711449-A
1 1/4"	29"	1	711450-A
1 1/4"	36"	1	711451-A
1 3/8"	16"	1	711452-A
1 3/8"	22"	1	711453-A
1 1/2"	22"	1	711454-A

Brocasiera de carburo

Para concreto no reforzado, ladrillo, block y materiales de construcción



Diámetro	Longitud total	Empaque Piezas	No. Parte
2"	12"	1	752103-A
2"	22"	1	752104-A
2-1/2"	22"	1	752106-A
3"	12"	1	752107-A
3"	22" (Incluye eje)	1	752108-A
5"	12"	1	752113-A
1-3/4"	(Repuesto de plato guía)	1	752140-A
2"	(Repuesto de plato guía)	1	752141-A
2-1/2"	(Repuesto de plato guía)	1	752142-A
3"	(Repuesto de plato guía)	1	752143-A
1-3/4"	s/a	1	752124-A
3"	s/a	1	752173-A
-	Adaptador Spline a SDS-Plus	1	752117-A
-	18"(Eje para brocasieras)	1	752136-A

El equipo estándar (accesorios), las especificaciones y las fotografías pueden variar. Los accesorios pueden no estar incluidos desde origen con las herramientas aunque se indiquen en este catálogo.



CINCEL PUNTA AUTOAFILABLE

La tecnología de nuestros aceros aseguran un afilado permanente y eficiencia en su vida útil.

Con un alto grado de extracción de material y no requiere re-afilado, estos nuevos aceros reducen el tiempo de trabajo y el costo de manera significativa.



**28.6mm
Hex**



**30mm
Hex**



**Zanco
SDS-MAX**

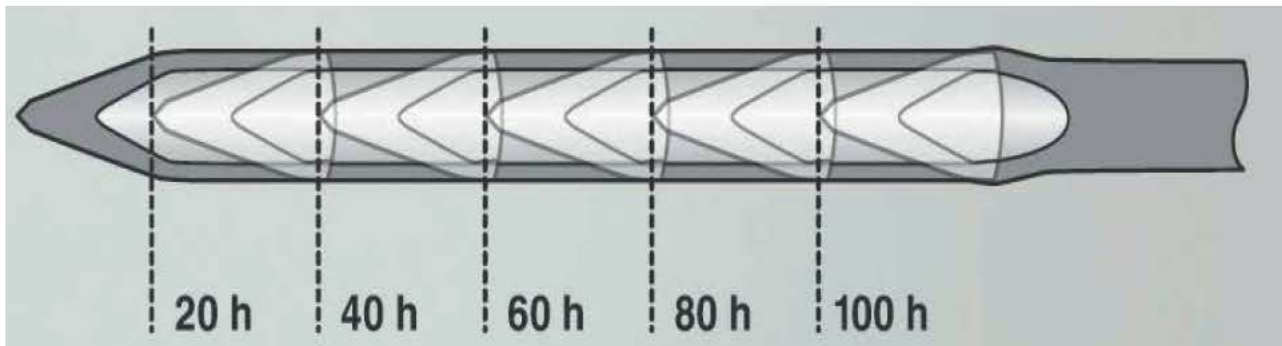

Innovación

Diseño único en forma de estrella que mantiene su forma



Beneficios

- No necesita re-afilado
- No se interrumpe el trabajo por re-afilado
- Sin costo de servicio

Cinceles									
									
Aplicación		Para martillos SDS-PLUS	Para martillos SDS-MAX	17mm Hex 11/16"	19mm Hex 3/4"	21mm Hex 13/16"	28.6mm Hex 1/8"	30mm Hex 13/16"	Makita pequeño
	Cinzel punta autoafilable Demolición en mampostería y concreto. Inicio de perforación en concreto No necesita usar tiempo para el reafilado		○						
	Cinzel punta Demolición en mampostería y concreto.	○	○	○	○		○	○	○
	Cinzel plano Ajuste de trabajo en mampostería y concreto. Ruptura, demolición, bordes y canalado en mampostería y concreto.	○	○	○	○		○	○	
	Cinzel ranurado Corte de canales en concreto.								
	Cinzel pala Remover residuos de concreto	○	○	○	○		○	○	
	Cortador de asfalto Cavado de arcilla, grava dura, grava apisonada y suciedad		○	○	○			○	
	Pisón Aplonamiento de asfalto y compactado de grava, suelo y suciedad				○		○	○	
	Martelina Desbaste de concreto y asfalto. (martelinar)		○						

El equipo estándar (accesorios), las especificaciones y las fotografías pueden variar. Los accesorios pueden no estar incluidos desde origen con las herramientas aunque se indiquen en este catálogo.



D-62424
Punta

D-62446
Pala

D-62430
Plano

CINCELES SDS PLUS

Nuevo empaque retráctil que **protege el cincel y evita que se oxide**



Cincel de punta
Para demoler concreto



Cincel plano
Para quebrar cantera, acanalar y remover grandes fragmentos de concreto



Cincel pala
Para remover incrustaciones y salpicaduras de concreto solidificado

----- **Con Clip**

Ideales para trabajos de construcción, albañilería o decoradores de interiores que utilicen **martillos SDS PLUS**

Usar en	Descripción	Longitud (mm)	Piezas por empaque	No. parte
martillos SDS PLUS	Cincel de punta	250 mm	1	D-62424
martillos SDS PLUS	Cincel plano	20 x 250mm	1	D-62430
martillos SDS PLUS	Cincel pala	50 x 215mm	1	D-62446

Cinceles para martillos rotativos y demolidores SDS-PLUS



Para modelo:

BHR200, BHR202, BHR241, BHR242, BHR243, BHR262/T, HR262D/TD, HR2451, HR2452, HR2432, HR2455, HR2470F, HR2470, HR2470FT, HR2470T, HR2811F, HR2810, HR2811FT, HR2810T, HR3200C, HR3210C, HR3210FCT

Cinzel de punta (Para demoler concreto)



Longitud (mm)	Tipo	No. Parte
160	-	D-08034
250	-	D-08713
400	-	D-19015
250	-	D-62424

Cinzel plano

(Para quebrar, cantera, acanalar y remover grandes fragmentos de concreto)



Longitud (mm)	Tipo	No. Parte
20 x 250	-	D-08729
20 x 400	-	D-19021
20 x 250	-	D-62430

Cinzel pala

(Cinzel ancho para remover incrustaciones y salpicaduras de concreto solidificado)



Longitud (mm)	Tipo	No. Parte
40 x 250mm	-	D-08735
80 x 250mm	-	D-61014
50 x 215mm	-	D-62446

Cinceles para demolición



Para modelo:

HR3540C, HR3541FC, HR4001C, HR4002, HR4010C, HR4011C, HR4501C, HR4510C, HR4511C, HR5201C, HR5210C, HR5211C, HM0860C, HM0870C, HM0871C, HM1111C, HM1101C, HM1203C, HM1213C, HM1214C

Cinzel de punta



Longitud (mm)	Tipo	Parte No.
400	(Auto afilable)	B-10621

Cinceles para martillos rotativos y demolidores SDS-MAX



Para modelo:

HR3540C, HR3541FC, HR4001C, HR4002, HR4010C, HR4011C, HR4501C, HR4510C, HR4511C, HR5201C, HR5210C, HR5211C, HM0860C, HM0870C, HM0871C, HM1111C, HM1101C, HM1203C, HM1213C, HM1214C

Cinzel de punta SDS-MAX

(Para demoler concreto)



Longitud	Tipo	No. Parte
280mm	-	A-80787
300mm	-	D-36463
400mm	-	A-80793
450mm	-	D-36479

El equipo estándar (accesorios), las especificaciones y las fotografías pueden variar. Los accesorios pueden no estar incluidos desde origen con las herramientas aunque se indiquen en este catálogo.

Cinzel plano SDS-MAX

(Para quebrar, cantera, acanalar y remover grandes fragmentos de concreto)



Tamaño	Tipo	No. Parte
25 x 280mm	-	A-80802
25 x 400mm	-	A-80818
12"	-	D-36485
18"	-	D-36491

Cinzel de pala

(Cinzel ancho para remover incrustaciones y salpicaduras de concreto solidificado)



Tamaño	Tipo	No. Parte
50 x 400mm	-	A-80824
12"	-	D-36516
12"	-	D-36522

Cinzel plano (para loza)



Tamaño (mm)	Tipo	No. Parte
50 x 300	-	A-80830

Cinzel punta 3/4" Hex



Tamaño	Tipo	No. Parte
12"	-	751421-A
18"	-	751422-A

Cinzel plano 3/4" Hex



Tamaño	Tipo	No. Parte
12"	-	751224-A
18"	-	751225-A

Cinzel punta 17mm



Tamaño	Tipo	No. Parte
50x280mm	Punta	D-08676
50x450mm	Punta	D-26751

Cinzel plano 17mm

Tamaño (mm)	Tipo	No. Parte
19x450mm	Plano	D-26602

Cinzel pala 17mm

(Para corte de asfalto)



Tamaño (mm)	Tipo	No. Parte
50x450mm	Pala	D-52532

Cinzel tipo pala



Tamaño (mm)	Tipo	No. Parte
105 x 400	-	A-25214

Cinzel punta Zanco Makita

Para HK1800

Maquinado en CNC y forjado con material fuerte aleado para durabilidad incrementada y mayor duración.



Tamaño	Tipo	No. Parte
8-3/4"	Punta	B-06921

Cinzel pala 3/4" Hex



Tamaño	Tipo	No. Parte
12"	-	751227-A
12"	-	751226-A
18"	-	751623-A

Cinzel corte de asfalto 3/4" Hex



Tamaño	Tipo	No. Parte
18"	-	751624-A

Pisón y porta pisón 3/4" Hex



Longitud	Tipo	No. Parte
-	-	751712-A
12"	Porta pisón	751716-A

Vástago porta pisón 3/4" Hex



Tamaño	Tipo	No. Parte
5"	-	751713-A

Cinzel punta 3/4" Hex.

Para HR3851



Tamaño	Tipo	No. Parte
12"	-	798146-1
18"	-	798147-9

Cinzel plano 3/4" Hex

Para HR3851



Tamaño	Tipo	No. Parte
12"	-	798139-8
18"	-	798140-3

Pisón y porta pisón 1-1/8"



Tamaño	Tipo	No. Parte
6"	Pisón	751710-A
8"	Pisón	751711-A
Longitud		
15"	Porta pisón	751103-A

Cinzel punta zanco Hex 1-1/8"



*Caja 5 Piezas

Longitud	Tipo	No. Parte
16"	-	798029-5
400mm	Autoafilable	B-10372
520mm	-	* D-21353-5
520mm	Con collarín	751420-A
520mm	Tipo Bosh	D-17675
520mm	Sin collarín	D-61569

Cinzel plano zanco Hex 1-1/8"



*Caja 5 Piezas

Longitud	Ancho	No. Parte
20-1/2"	28mm	751220-A
20-1/2"	28mm	751222-A
520mm	28mm	* D-21369-5
420mm	28mm	D-17647
520mm	28mm	D-17681
520mm Sin collarín	28mm	D-61575

El equipo estándar (accesorios), las especificaciones y las fotografías pueden variar. Los accesorios pueden no estar incluidos desde origen con las herramientas aunque se indiquen en este catálogo.

Cinzel pala zanco Hex 1- 1/8"



*Usar con martillos hexagonales 3/4", 1- 1/8"

**Caja con 5 piezas

Longitud (mm)	Ancho	No. Parte
520mm	75mm	751221-A
520mm	75mm	**D-21347-5
400mm	75mm	D-29228
520mm	75mm	D-20725
520mm Sin collarín	75mm	D-61581

Cortador de asfalto zanco Hex 1-1/8"



*Usar con martillos hexagonales 3/4", 1- 1/8"

Longitud (mm)	Ancho	No. Parte
580mm	140mm	751622-A

Cavador zanco Hex 1-1/8"



*Usar con martillos hexagonales 3/4", 1- 1/8"

Longitud (In)	Tipo	No. Parte
12-1/2"	-	*751621-A

Cilindro para clavos zanco Hex 1-1/8"



*Usar con martillos hexagonales 3/4", 1- 1/8"

Longitud (In)	Tipo	No. Parte
5-1/2"	-	*751106-A

Perno para barra de tierra zanco Hex 1-1/8"



*Usar con martillos hexagonales 3/4", 1- 1/8"

Longitud (In)	Tipo	No. Parte
14-1/2"	-	*751101-A
16"	-	751102-A

Cabeza del buje zanco Hex 1-1/8"



*Usar con martillos hexagonales 3/4", 1- 1/8"

Longitud (mm)	Tipo	No. Parte
12"	-	*751703-A

Martelina zanco Hex 1-1/8"



*Usar con martillos hexagonales 3/4", 1- 1/8"

Longitud (mm)	Tipo	No. Parte
14-3/4"	-	*751717-A

Cinzel punta Hex 1-3/16"



Diámetro	Largo	No. Parte
1-3/16"	310mm	D-15279
1-3/16"	400mm	D-15285

Cinzel plano Hexagonal 1-3/16"



*Especial para HM1500B

Diámetro	Largo	No. Parte
1-3/8"	406mm (Zanco Makita Largo)	*A-80597
1-3/16"	310mm (Frio)	D-34811
1-3/16"	310mm	D-15291
1-3/16"	400mm	D-15300

ACCESORIOS

Brocas concreto

Cinzel pala Hexagonal 1-3/16"



Diámetro	Largo	No. Parte
1-3/16"	310x75mm	D-23868

Cinzel para asfalto Hexagonal 1-3/16"



Longitud	Tipo	No. Parte
1-3/16"	500x120mm	B-10300

Pisón Hexagonal 1-3/16"

Zanco Makita largo



Diámetro	Tipo	No. Parte
1-3/16"	200mm	A-31485

Martelina SDS-Max



Longitud	Tipo	No. Parte
10"	-	751715-A

Cinzel SDS-Max

Cinzel ancho para corte de asfalto



Longitud	Tipo	No. Parte
12"	-	751625-A

Carrito transportador para martillos



* No incluye herramienta ni cinceles

Uso	Empaques Plezas	No. Parte
Martillos HM1812, HM1802, HM1810, HM1801	1	D-54972

El equipo estándar (accesorios), las especificaciones y las fotografías pueden variar. Los accesorios pueden no estar incluidos desde origen con las herramientas aunque se indiquen en este catálogo.

Puntas



Hex (H)



T



Aleación de acero al cromo molibdeno



Pz



Phillips (Ph)



Para entrada cuadrada 3/8"



Cuadrada (Sq)



T_H



Para entrada cuadrada 1/2"



Ranurada (SI)



Con magnetismo



Impact GOLD

Xtreme Torsion Technology



Punta de torsión

Disponible en Ph, Pz, T & Sq.
Ambos de 25mm no magnético y 50mm magnético.



Punta de metal con torsión en duro

Específicamente adaptado para proporcionar una conexión más duradera entre tornillo + punta metálica aplicaciones de torque. (Disponible sólo en Ph2 - 25mm y 50mm No-Mag Mag).



Larga vida

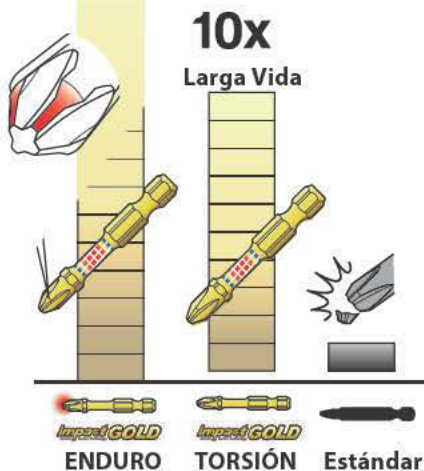

10x Vida



15x Vida



Punta de metal con torsión para madera

Específicamente adaptado para proporcionar una conexión más duradera entre tornillo + punta metálica aplicaciones de torque. (Disponible sólo en Ph2 - 25mm y 50mm No-Mag Mag).

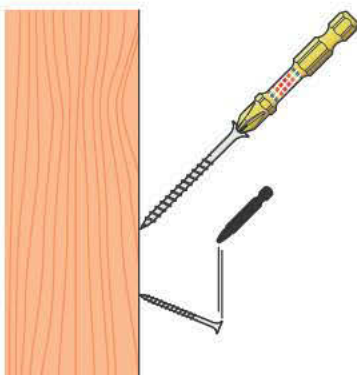

10x+ Vida



Porta punta con torsión



Porta punta ultra magnética de torsión

El dado magnético sostiene incluso a los tornillos largos de manera segura para un atornillado preciso.

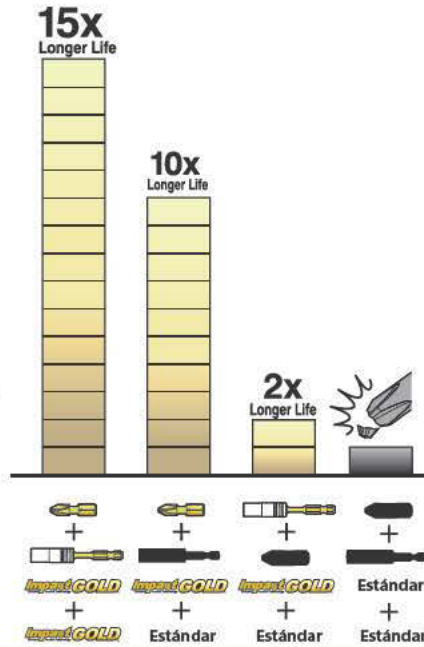

Extensión de dado

El resorte conserva el sujetador, eliminando toda acumulación de virutas en el imán que impide el correcto conexión de fijación.

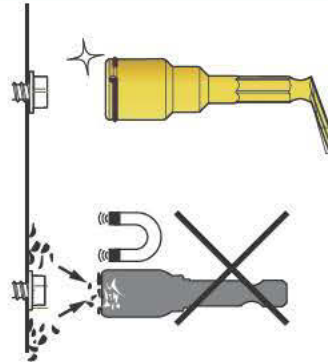

Adaptador de dado

El dado puede ser inclinado a 15° para ayudar en la fijación en espacios reducidos

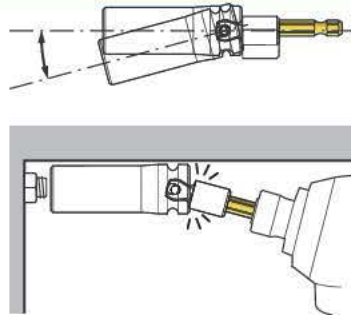

<p>Makita 10x Lifes Impact GOLD</p> <p>+</p> <p>Punta de atornillar con torsión</p> <p>El rango de la punta es identificable por su aplicación metal / madera en el lado izquierdo del empaque</p>	<p>Makita 10x Lifes Impact GOLD</p> <p>+</p> <p>Torsión punta de agarre madera</p> <p>El rango está diseñado específicamente para atornillado en madera y es identificable en aplicaciones de madera al lado izquierdo del empaque, así como el "agarre" en la imagen de la derecha.</p>	<p>Makita 15x Lifes Impact GOLD</p> <p>+</p> <p>Torsión endureo punta de metal</p> <p>El rango está diseñado específicamente para atornillado en metal y es identificable por la aplicación de metal en el lado izquierdo del paquete y "puntas fuertes" en imagen de la derecha, el "agarre" en la imagen de la derecha."</p>
--	--	--

Puntas para atornillar

Tipo zanco hex. 1/4" (forma-C)		
A	Forma-C	

Tipo zanco hex. 1/4" (forma-E)		NZ	MZ
B	Forma-E (Single Ended)		
		14mm	9.5mm
C	Forma-E (Double Ended)		
		17mm	11mm

Tipo de tornillo

Phillips (Ph)		T		Plano (Sl)	
Pozidriv		T.H		Hex (H)	
Cuadrado (Sq)					

Punta de torsión



	Tamaño	Longitud (mm)	Zanco tipo	Empaque Piezas	No. Parte
+	Ph 1	25	A	2	B-28329
	Ph 2	25	A	5	B-28357
	Ph 2 (Grip)	25	A	5	B-28494
	Ph 2 (Enduro)	25	A	5	B-28519
+	Pz 1	25	A	2	B-28444
	Pz 2	25	A	5	B-28472
*	T 10	25	A	2	B-28391
	T 20	25	A	2	B-28416
	T 25	25	A	2	B-28422
	T30	25	A	2	B-28379
□	Sq2	25	A	2	B-28438

Punta con torsión

Con Magnético



* Para tornillos de tablaroca y madera
** Para tornillos autoperforantes en metal



	Tamaño	Longitud (mm)	Zanco tipo	Empaque Piezas	No. Parte
+	Ph 1	50	MZ-B	2	B-28167
	Ph 2	50	MZ-B	2	B-28173
	* Ph 2 (Grip)	50	MZ-B	2	B-28307
	** Ph 2 (Enduro)	50	MZ-B	2	B-28313
	Ph 2	50	Mz	Blister	B-39160
+	Ph 3	50	MZ-B	2	B-28189
	Pz 1	50	MZ-B	2	B-28276
	Pz 2	50	MZ-B	2	B-28282
*	Pz 2	50	Mz	Blister	B-39182
	Pz 3	50	MZ-B	2	B-28298
	T 10	50	MZ-B	2	B-28226
	T 15	50	MZ-B	2	B-28232
	T 20	50	MZ-B	2	B-28248
	T 25	50	MZ-B	2	B-28254
	T 30	50	MZ-B	2	B-28260
□	Sq 1	50	MZ-B	2	B-28195
	Sq 2	50	MZ-B	2	B-28204
	Sq 3	50	MZ-B	2	B-28210

Puntas para atornillar

Triptico con 1 pieza



	Tamaño	Longitud	Tipo	Empaque Piezas	No. Parte
+	Ph 2	2"	Phillips	1	B-28955
+	Pz 2	2"	Pozidriv	1	B-28933
*	T 25	2"	T	1	B-28949

Porta punta con torsión



Longitud (mm)	Zanco tipo	Empaque piezas	No. Parte
66	MZ-B	1	B-28525

El equipo estándar (accesorios), las especificaciones y las fotografías pueden variar. Los accesorios pueden no estar incluidos desde origen con las herramientas aunque se indiquen en este catálogo.

Porta punta ultra magnética con torsión



*Caja con 24 piezas (Display p/venta individual)

Longitud (mm)	Zanco tipo	Empaque Piezas	No. Parte
79	MZ-B	79	B-28531
79	MZ-B	79	*B-28531-24

Adaptador de dado



Tamaño	Longitud (mm)	Zanco tipo	Empaque piezas	No. Parte
SQ 3/8"	56	MZ-B	1	B-28547
SQ 1/2"	56	MZ-B	1	B-28553

Extensión de dado



Tamaño	Longitud (mm)	Zanco tipo	Empaque piezas	No. Parte
8mm(5/16")	50	MZ-B	1	B-28569
9.6mm(3/8")	50	MZ-B	1	B-28575

Guía buscadora magnética 8mm Impact Gold



Tamaño	Zanco	Zanco tipo	Empaque piezas	No. Parte
8mm(5/16")	1/4" Hex	MZ	1	B-40266
9.6mm(3/8")	1/4" Hex	MZ	1	B-40272
8mm(5/16")	1/4" Hex	MZ	3	B-40353
9.6mm(3/8")	1/4" Hex	MZ	3	B-40369

Juego de puntas de torsión

11 Piezas



Tamaño	Longitud (mm)	Zanco tipo	Empaque piezas	No. Parte
Ph1, Ph2, Ph3	25	A	1	B-28597
Pz1, Pz2, Pz3	25	A		
T15, T20, T25, T30	25	A		
Torsion Bit Holder	66	MZ-B		

Juego de puntas de torsión magnéticas

11 piezas

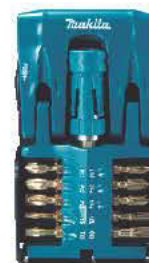

Tamaño	Longitud (mm)	Zanco tipo	Empaque piezas	No. Parte	
+	Ph1, Ph2, Ph3	25	A	1	B-30754
+	Pz1, Pz2, Pz3	25	A		
+	T15, T20, T25, T30	25	A		
	Soporte de puntas de torsión	79	MZ-B		

Atornillador manual tipo matraca

47 accesorios



Tamaño	Empaque Piezas	Contenido	No. Parte
Estándar	1 Juego	PH0x1, PHx2, PH2x6, PH3x2 T10x1, T15x1, T20x1, T25x2, T27x1, T30x1, T40x1 SL6-8x1, SL8-10x2, SL10-12x1 H1/8"x1, H3/16"x1, H1/4"x1 SQ1x3, SQ2x6, SQ3x3, 36mm Dados 3/16"1/4", 9/32", 5/16", 11/32", 3/8", 7/16", Adaptador para dados.	B-50289

Desarmadores de impacto

Al golpear la cabeza del desarmador con el martillo, gracias a su mecanismo interior, la punta del desarmador **GIRA**



Descripción	Medida	Empaque piezas	No. Parte
Desarmador de impacto	125mm Ph2	1	B-42438
Desarmador de impacto	150mm Ph3	1	B-42444

Atornillador manual tipo matraca



Incluye punta Phillips #2 (1Pz.)

Tamaño	Empaque Piezas	No. Parte
Estándar	1	D-58849

Punta Phillips (Ph # 0) x 4"



Tamaño	Empaque piezas	No. Parte
6mm	1	B-42575

Punta para atornillar forma E 3-1/2"

Tamaño	Longitud (mm)	Zanco tipo	Empaque piezas	No. Parte
Ph1	90	MZ	1	B-57772
Ph2	90	MZ	1	B-57788
Ph3	90	MZ	1	B-57794
Sq1	90	MZ	1	B-57803
Sq2	90	MZ	1	B-57819
Sq3	90	MZ	1	B-57825
Pz1	90	MZ	1	B-59879
Pz2	90	MZ	1	B-59885
Pz3	90	MZ	1	B-59891
T15	90	MZ	1	B-59900
T20	90	MZ	1	B-59916
T25	90	MZ	1	B-59922
T30	90	MZ	1	B-59938

Punta para atornillar forma E 6"

Tamaño	Longitud (mm)	Zanco tipo	Empaque piezas	No. Parte
Ph1	150	MZ	1	B-57831
Ph2	150	MZ	1	B-57847
Ph3	150	MZ	1	B-57853
Sq1	150	MZ	1	B-57869
Sq2	150	MZ	1	B-57875
Sq3	150	MZ	1	B-57881
Pz1	150	MZ	1	B-59944
Pz2	150	MZ	1	B-59950
Pz3	150	MZ	1	B-59966
T15	150	MZ	1	B-59972
T20	150	MZ	1	B-59988
T25	150	MZ	1	B-59994
T30	150	MZ	1	B-60006

Punta para atornillar forma E

Tamaño	Longitud (mm)	Zanco tipo	Empaque piezas	No. Parte
Ph1	50	MZ	3	B-25214
Ph2	50	MZ	3	B-25220
Ph3	50	MZ	3	B-25236
Ph1	50	MZ	3	B-25513
Ph2	50	MZ	3	B-25529
Ph3	50	MZ	3	B-25535
Ph1	50	MZ	3	B-25812
Ph2	50	MZ	3	B-25828
Ph3	50	MZ	3	B-25834
Sq1	50	MZ	3	B-25781
Sq2	50	MZ	3	B-25797
Sq3	50	MZ	3	B-25806
Sq1	50	MZ	3	B-25840
Sq2	50	MZ	3	B-25856
Sq3	50	MZ	3	B-25862

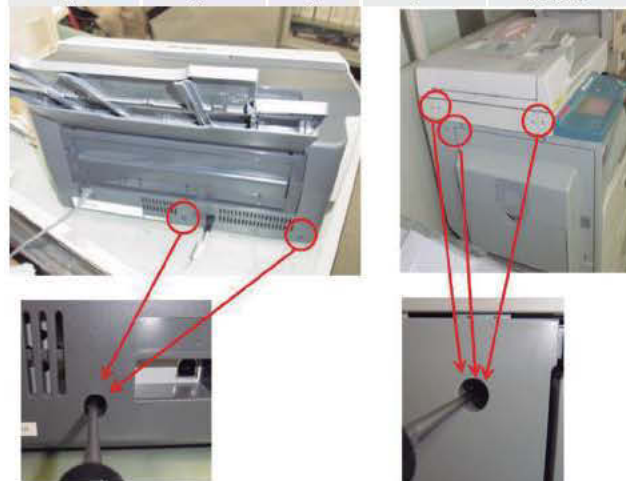

El equipo estándar (accesorios), las especificaciones y las fotografías pueden variar. Los accesorios pueden no estar incluidos desde origen con las herramientas aunque se indiquen en este catálogo.

Punta de torsión p/ atornillar



Tamaño	Longitud (mm)	Zanco tipo	Empaque Piezas	No. Parte
PH 2	100	MZ	1	B-56948
PZ 2	100	MZ	1	B-56954

Punta para atornillar doble "alta torsión"



Con magnético



* Japanese Package

Tamaño	Longitud (mm)	Zanco tipo	Empaque Piezas	No. Parte	
+	Ph 2	65	NZ-C	3	A-49563 *
	Ph 2	85	NZ-C	3	A-49585 *
	Ph 2	110	NZ-C	3	A-49600 *
	Ph 2	150	NZ-C	3	A-50120 *
	Ph2 (Slim)	65	NZ-C	3	A-50924 *
	Ph 1	65	MZ-C	3	B-21836
	Ph 1	85	MZ-C	3	B-21842
	Ph 1	110	MZ-C	3	B-21858
	Ph 2	85	MZ-C	3	B-12326
	Ph 2	110	MZ-C	3	B-21864
	Ph 3	65	MZ-C	3	B-21870
	Ph 3	85	MZ-C	3	B-21886
Ph 3	110	MZ-C	3	B-21892	
*	Pz 1	65	MZ-C	3	B-21901
	Pz 1	85	MZ-C	3	B-21917
	Pz 1	110	MZ-C	3	B-21923
	Pz 2	65	MZ-C	3	B-20719
	Pz 2	85	MZ-C	3	B-12790
	Pz 2	110	MZ-C	3	B-21939
	Pz 3	65	MZ-C	3	B-20725
	Pz 3	85	MZ-C	3	B-20731
	Pz 3	110	MZ-C	3	B-21945

Punta para atornillar doble "alta torsión"



Tamaño	Longitud	Zanco tipo	Empaque Piezas	No. Parte	
□	1	1"	MZ-C	1	784217-A
	1	2-3/4"	MZ-C	1	784607-A
	1	6"	MZ-C	1	784610-A
	2	6"	MZ-C	1	784611-A
	3	6"	MZ-C	1	784612-A
	Sq1	2-1/2" (65mm)	MZ-C	3	B-20884
	Sq1	3-3/8" (85mm)	MZ-C	3	B-20890
	Sq1	4-3/8" (110mm)	MZ-C	3	B-20909
	Sq2	2-1/2" (65mm)	MZ-C	3	B-20915
	Sq2	3-3/8" (85mm)	MZ-C	3	B-20921
	Sq2	4-3/8" (110mm)	MZ-C	3	B-20937
	Sq3	2-1/2" (65mm)	MZ-C	3	B-20943
	Sq3	3-3/8" (85mm)	MZ-C	3	B-20959
	Sq3	4-3/8" (110mm)	MZ-C	3	B-20965

Caja flip top (Impact Gold)



Tamaño	Longitud (mm)	Zanco tipo	Empaque piezas	No. Parte	
+	Ph 2	25	A	15	B-39512
*	Pz 2	25	A	15	B-39534
□	Sq 2	25	A	15	B-39556

Caja flip top (Impact Gold)



Con magnético



Impact GOLD
Xtreme Torxion Technology

Tamaño	Longitud (mm)	Zanco tipo	Empaque piezas	No. Parte	
+	Ph 2	50	MZ	10	B-42874
*	Pz 2	50	MZ	10	B-39540
□	Sq 2	50	MZ	10	B-39562

ACCESORIOS

Puntas impact gold
Con anillo magnetizador



Contiene	Empaque Piezas	No. Parte
Puntas PZ2 x 2" con magnetizador	Set de 5 piezas	B-42472
Puntas PH2 x 2" con magnetizador	Set de 5 piezas	B-42488
Puntas T25 x 2" con magnetizador	Set de 5 piezas	B-42494
Juego de puntas PH,PZ,T25x2" con magnetizador	Set de 5 piezas	B-42503
Puntas cuadro 2x2" con magnetizador	Set de 5 piezas	B-42519



Anillo magnetizador para puntas "Mag Boost" Impact Gold



Descripción	Empaque Piezas	No. Parte
Anillo magnetizador para puntas "Mag Boost" Impact Gold	1	B-42422

Bote magnético c/puntas impact gold
10pzs



Tamaño	Empaque piezas	No. Parte
+	Ph2	10 Piezas
		B-52912

Exhibidor de puntas con magnetizador
30 juegos "Mag Boost"



Contiene	Empaque piezas	No. Parte
B-42503 5 Sets de 5 puntas c/u PH2,PZ2,T25 y 1 magnetizador	Caja	B-42525
B-42488 5 Sets de 5 puntas c/u PH2, y 1 magnetizador		
B-42472 5 Sets de 5 puntas c/u PZ2, y 1 magnetizador		
B-42494 5 Sets de 5 puntas c/u T25, y 1 magnetizador		
B-42422 2 cajas con 10 magnetizadores		
Incluye 1 copete para exhibición y 1 punta muestra		

Juego de puntas impact gold c/magnetizador
26 pzs



Contiene	Empaque piezas	No. Parte
Puntas cortas de torsión (25mm) ⊕ 1xPh1, 2xPh2, 1xPh3 ⊖ 1xPz1, 2xPz2, 1xPz3 ○ 1xSq1, 2xSq2, 1xSq3 ○ 1xT10, 1xT15, 2xT20, 2xT25, 2xT30 Puntas torsión (50mm) ⊕ 1xPh2 ⊖ 1xPz2 ○ 1xSq2 ○ 1xT25	1 Juego	B-49915
Anillo Magnetizador para puntas "Mag Boost" Impact Gold Porta punta ultramagnética con torsión		

Juego de puntas impact gold c/dados
26pzs



Contiene	Empaque piezas	No. Parte
Puntas cortas de torsión (25mm) ⊕ 1xPh1, 2xPh2, 1xPh3 ⊖ 1xPz1, 2xPz2, 1xPz3 ○ 1xSq1, 2xSq2, 1xSq3 ○ 1xT10, 1xT15, 2xT20, 2xT25, 2xT30 Puntas torsión (50mm) ⊕ 1xPh2 ⊖ 1xPz2	1 Juego	B-49921
Anillo Magnetizador para puntas "Mag Boost" Impact Gold Guía buscadora 1xH8, 1xH10 Porta punta ultramagnética con torsión		

El equipo estándar (accesorios), las especificaciones y las fotografías pueden variar. Los accesorios pueden no estar incluidos desde origen con las herramientas aunque se indiquen en este catálogo.



Makita

ACCESORIOS

IMPACT X™

IMPACT X
Línea Profesional



NUEVO

NUEVA LÍNEA PROFESIONAL

Diseñadas específicamente para soportar las exigencias de los usuarios profesionales que requieran brocas de trabajo comercial y accesorios de sujeción que soporten la fuerza de aplicaciones de atornillado de alto rendimiento

Construcción de **acero S2**
con rendimiento optimizado
para mayor duración

Superficie de fosfato de manganeso
para resistencia de corrosión avanzada

Tratamiento térmico que provee más flexibilidad y
mayor durabilidad que las puntas estándar

ACCESORIOS

Punta phillips 1" Impact X



IMPACTX

Tamaño	Longitud	Empaque piezas	No. Parte
⊕ Ph1	1" (25mm)	2 Piezas	A-96453
⊕ Ph2	1" (25mm)	2 Piezas	A-96469
⊕ Ph3	1" (25mm)	2 Piezas	A-96481

Punta phillips 1" Impact X

Bolsa de plastico



IMPACTX

Tamaño	Longitud	Empaque piezas	No. Parte
⊕ Ph1	1" (25mm)	50	A-98821
⊕ Ph2	1" (25mm)	50	A-96475
⊕ Ph3	1" (25mm)	50	A-96497

Punta phillips 1" #2 Impact X

Caja Tic tac



* A-97302-10



Tamaño	Longitud	Empaque piezas	No. Parte
⊕ Ph2	1" (25mm)	Caja c/10Pzs x25	* A-97302-10

Punta phillips 1" #2 Impact X

Vitrolero



IMPACTX

Tamaño	Longitud	Empaque piezas	No. Parte
⊕ Ph2	1" (25mm)	200 Piezas	A-97324

Punta phillips 1" #2 Impact X

Para panel de yeso



IMPACTX

Tamaño	Longitud	Empaque piezas	No. Parte
⊕ Ph2	1" (25mm)	2 Piezas	A-98837

Punta phillips 1" #2 Impact X

Para panel de yeso / caja Tic tac



* A-98843-10



Tamaño	Longitud	Empaque piezas	No. Parte
⊕ Ph2	1" (25mm)	Caja c/10 pzs x25	* A-98843-10

Punta phillips 1" #2 Impact X

Para tablaroca / bolsa de plastico



IMPACTX

Tamaño	Longitud	Empaque piezas	No. Parte
⊕ Ph2	1" (25mm)	50 Piezas	A-98859

El equipo estándar (accesorios), las especificaciones y las fotografías pueden variar. Los accesorios pueden no estar incluidos desde origen con las herramientas aunque se indiquen en este catálogo.

Puntas

Punta phillips 1" Impact X
Para tablaroca / vitrolero



IMPACTX

Tamaño	Longitud	Empaque piezas	No. Parte
⊕ Ph2	1" (25mm)	200 Piezas	A-98865

Punta phillips 2" Impact X



IMPACTX

Tamaño	Longitud	Empaque piezas	No. Parte
⊕ Ph1x2"	2" (51mm)	2 Piezas	A-96643
⊕ Ph2x2"	2" (51mm)	2 Piezas	A-96659
⊕ Ph3x2"	2" (51mm)	2 Piezas	A-96687
⊕ Ph2x2"	2" (51mm)	5 Piezas	A-96665

Punta phillips 2" Impact X
Caja Tic tac



IMPACTX

Tamaño	Longitud	Empaque piezas	No. Parte
⊕ Ph2x2"	2" (51mm)	10 cajas c/15 Pzs	* A-96671-10

Punta phillips 2" Impact X
Vitrolero



IMPACTX

Tamaño	Longitud	Empaque piezas	No. Parte
⊕ Ph2x2"	2" (51mm)	100	A-97368

ACCESORIOS

Punta phillips 2" Impact X
Bolsa de plástico



IMPACTX

Tamaño	Longitud	Empaque piezas	No. Parte
⊕ Ph1x2"	2" (51mm)	50	A-98974
⊕ Ph2x2"	2" (51mm)	50	A-98980
⊕ Ph3x2"	2" (51mm)	50	A-98996

Punta phillips 3 1/2" Impact X



IMPACTX

Tamaño	Longitud	Empaque piezas	No. Parte
⊕ Ph1	3 1/2"	1 pza.	A-96811

Punta phillips 3 1/2" Impact X



IMPACTX

Tamaño	Longitud	Empaque piezas	No. Parte
⊕ Ph2	3 1/2"	1 Pieza	A-96827
⊕ Ph3	3 1/2"	1 Pieza	A-96833

Punta phillips 3 1/2" Impact X



IMPACTX

Tamaño	Longitud	Empaque piezas	No. Parte
⊕ Ph1	3 1/2"	50 Piezas	A-99100
⊕ Ph2	3 1/2"	50 Piezas	A-99116
⊕ Ph3	3 1/2"	50 Piezas	A-99122

ACCESORIOS

Punta phillips 6" Impact X



IMPACTX

Tamaño	Longitud	Empaque piezas	No. Parte
⊕ Ph1x6"	6"	1	A-96877
⊕ Ph2x6"	6"	1	A-96883
⊕ Ph3x6"	6"	1	A-96899

Punta phillips 6" Impact X



IMPACTX

Tamaño	Longitud	Empaque piezas	No. Parte
⊕ Ph1x6"	6"	25	A-99166
⊕ Ph2x6"	6"	25	A-99172
⊕ Ph3x6"	6"	25	A-99188

Punta phillips 12" Impact X



IMPACTX

Tamaño	Longitud	Empaque piezas	No. Parte
⊕ Ph2	12"	1 pieza	A-96914

Punta phillips 12" Impact X



IMPACTX

Tamaño	Longitud	Empaque piezas	No. Parte
⊕ Ph1x12"	12"	10	A-99225
⊕ Ph2x12"	12"	10	A-99231
⊕ Ph3x12"	12"	10	A-99247

El equipo estándar (accesorios), las especificaciones y las fotografías pueden variar. Los accesorios pueden no estar incluidos desde origen con las herramientas aunque se indiquen en este catálogo.

Puntas

Puntas planas Impact X



IMPACTX

Tamaño	Longitud	Empaque piezas	No. Parte
● SI 8	1" (25mm)	2	A-96621
● SI 10	1" (25mm)	2	A-96637
● SI 8	2"	2	A-96796
● SI 10	2"	2	A-96805

Punta torx 1" Impact X



IMPACTX

Tamaño	Longitud	Empaque piezas	No. Parte
⊕ T10	1" (25mm)	2	A-96540
⊕ T15	1" (25mm)	2	A-96556
⊕ T20	1" (25mm)	2	A-96562
⊕ T25	1" (25mm)	2	A-96578
⊕ T27	1" (25mm)	2	A-96584
⊕ T30	1" (25mm)	2	A-96590
⊕ T40	1" (25mm)	2	A-96609

Punta torx 1" Impact X Bolsa de plástico



IMPACTX

Tamaño	Longitud	Empaque piezas	No. Parte
⊕ T10	1" (25mm)	50	A-98902
⊕ T15	1" (25mm)	50	A-98918
⊕ T20	1" (25mm)	50	A-98924
⊕ T25	1" (25mm)	50	A-98930
⊕ T27	1" (25mm)	50	A-98946
⊕ T30	1" (25mm)	50	A-98952
⊕ T40	1" (25mm)	50	A-98968

Puntas

Set de puntas torx 1" Impact X
7 piezas

IMPACTX



Tamaño	Longitud	Empaque piezas	No. Parte
T10 T20 T27 T40 T15 T25 T30	1" (25mm)	7	A-96615

Punta torx 2" Impact X

IMPACTX



Tamaño	Longitud	Empaque piezas	No. Parte
T10	2"	2	A-96724
T15	2"	2	A-96730
T20	2"	2	A-96746
T25	2"	2	A-96752
T27	2"	2	A-96768
T30	2"	2	A-96774
T40	2"	2	A-96780

Punta torx 2" Impact X
Bolsa de plástico

IMPACTX



Tamaño	Longitud	Empaque piezas	No. Parte
T10	2"	50	A-99035
T15	2"	50	A-99041
T20	2"	50	A-99057
T25	2"	50	A-99063
T27	2"	50	A-99079
T30	2"	50	A-99085
T40	2"	50	A-99091

ACCESORIOS

Punta cuadro 1" Impact X
Bolsa de plástico

IMPACTX



Tamaño	Longitud	Empaque piezas	No. Parte
Sq1	1" (25mm)	2 Piezas	A-96506
Sq2	1" (25mm)	2 Piezas	A-96512
Sq3	1" (25mm)	2 Piezas	A-96534

Punta cuadro 1" Impact X
Bolsa de plástico

IMPACTX



Tamaño	Longitud	Empaque piezas	No. Parte
Sq1	1" (25mm)	50 Piezas	A-98887
Sq2	1" (25mm)	50 Piezas	A-96528
Sq3	1" (25mm)	50 Piezas	A-98893

Punta cuadro Impact X
25 piezas x 10 cajas

IMPACTX



Tamaño	Longitud	Empaque piezas	No. Parte
Sq2	1" (25mm)	25 piezas (10 cajas)	A-97330-10

Punta cuadro 2" Impact X

IMPACTX



Tamaño	Longitud	Empaque piezas	No. Parte
SQ1x2"	2" (51mm)	2 Piezas	A-96693
SQ2x2"	2" (51mm)	2 Piezas	A-97405-10
SQ2x2"	2" (51mm)	2 Piezas	A-96718

ACCESORIOS

Punta cuadro 2" Impact X



IMPACT X

Tamaño	Longitud	Empaque piezas	No. Parte
<input type="checkbox"/> SQ1x2"	2" (51mm)	50	A-99007

Punta cuadro 2" Impact X

Bolsa de plástico



IMPACT X

Tamaño	Longitud	Empaque piezas	No. Parte
<input type="checkbox"/> SQ2x2"	2" (51mm)	2	A-96702
<input type="checkbox"/> SQ2x2"	2" (51mm)	50	A-99013
<input type="checkbox"/> SQ3x2"	2" (51mm)	50	A-99029

Punta cuadro 3 1/2" Impact X



IMPACT X

Tamaño	Longitud	Empaque piezas	No. Parte
<input type="checkbox"/> SQ1	3 1/2"	1 Pieza	A-96849
<input type="checkbox"/> SQ2	3 1/2"	1 Pieza	A-96855
<input type="checkbox"/> SQ3	3 1/2"	1 Pieza	A-96861

Punta cuadro 3 1/2" Impact X



IMPACT X

Tamaño	Longitud	Empaque piezas	No. Parte
<input type="checkbox"/> SQ1	3 1/2"	50	A-99138
<input type="checkbox"/> SQ2	3 1/2"	50	A-99144
<input type="checkbox"/> SQ3	3 1/2"	50	A-99150

Punta cuadro 6" Impact X



IMPACT X

Tamaño	Longitud	Empaque piezas	No. Parte
<input type="checkbox"/> SQ2	6"	1	A-96908

Punta cuadro 6" Impact X



IMPACT X

Tamaño	Longitud	Empaque piezas	No. Parte
<input type="checkbox"/> SQ1	6"	25	A-99194
<input type="checkbox"/> SQ2	6"	25	A-99203
<input type="checkbox"/> SQ3	6"	25	A-99219

Punta cuadro 12" Impact X



IMPACT X

Tamaño	Longitud	Empaque piezas	No. Parte
<input type="checkbox"/> SQ1	12"	10	A-99253
<input type="checkbox"/> SQ2	12"	10	A-99269
<input type="checkbox"/> SQ3	12"	10	A-99275

Adaptador magnético Impact X



IMPACT X

Longitud	Empaque piezas	No. Parte
2-3/8" (60mm)	1	A-96920
3" (76mm)	1	A-96942
6" (152mm)	1	A-96958
12" (305mm)	1	A-96964

El equipo estándar (accesorios), las especificaciones y las fotografías pueden variar. Los accesorios pueden no estar incluidos desde origen con las herramientas aunque se indiquen en este catálogo.

Adaptador magnético Impact X

Caja Flip top



IMPACTX

Longitud	Empaque piezas	No. Parte
2-3/8" (60mm)	10	A-96936
3" (76mm)	10	A-99281
6" (152mm)	10	A-99297
12" (305mm)	10	A-99306

Adaptador magnético Impact X



IMPACTX

Longitud	Empaque piezas	No. Parte
2-3/8" (60mm)	1	A-96970
3" (76mm)	1	A-96992
6" (152mm)	1	A-97003
12" (305mm)	1	A-97019

Adaptador magnético Impact X

Caja Flip top



IMPACTX

Longitud	Empaque piezas	No. Parte
2-3/8" (60mm)	10	A-96986
3" (76mm)	10	A-99312
6" (152mm)	10	A-99328
12" (305mm)	10	A-99334

Guía buscadora Impact X



IMPACTX

Longitud	Empaque piezas	No. Parte
3" (76mm)	1	A-97075
4-3/4"	1	A-97081

Guía buscadora Impact X

Caja Flip top



IMPACTX

Longitud	Empaque piezas	No. Parte
3" (76mm)	10	A-99340
4-3/4"	10	A-99356

Guía buscadora Impact X

Vitrolero



IMPACTX

Longitud	Empaque piezas	No. Parte
3" (76mm)	25	A-97380
4-3/4"	25	A-97396

Adaptador para dado, cuadro 1/4" Impact X



IMPACTX

Longitud	Cuadro	Zanco	Empaque piezas	No. Parte
2"	1/4"	1/4" Hex	1	A-97025
6"	1/4"	1/4" Hex	1	A-97031
12"	1/4"	1/4" Hex	1	A-97047

Adaptador para dado, cuadro 1/4" Impact X



IMPACTX

Longitud	Cuadro	Zanco	Empaque piezas	No. Parte
2"	1/4"	1/4" Hex	10	A-99362
6"	1/4"	1/4" Hex	10	A-99378
12"	1/4"	1/4" Hex	10	A-99384

ACCESORIOS

Puntas

Adaptador para dado, cuadro 3/8" Impact X



IMPACTX

Longitud	Cuadro	Zanco	Empaque piezas	No. Parte
2"	3/8"	1/4" Hex	1	A-97053
2"	3/8"	1/4" Hex	10	A-99390
6"	3/8"	1/4" Hex	10	A-99409
12"	3/8"	1/4" Hex	10	A-99415

Adaptador para dado, cuadro 1/2" Impact X



IMPACTX

Longitud	Cuadro	Zanco	Empaque piezas	No. Parte
2"	1/4"	1/4" Hex	1	A-97069
2"	3/8"	1/4" Hex	3	A-97673
2"	1/2"	1/4" Hex	10	A-99421
6"	1/2"	1/4" Hex	10	A-99437
12"	1/2"	1/4" Hex	10	A-99443

Puntas magnéticas Impact X



IMPACTX

Longitud	Medida	Tipo	Empaque piezas	No. Parte
1-3/4"	1/4"	Hex	3	A-97645
2-9/16"	1/4"	Hex	1	A-97112
6"	1/4"	Hex	1	A-97134
1-3/4"	5/16"	Hex	1	A-97140
2-9/16"	5/16"	Hex	1	A-97162
6"	5/16"	Hex	1	A-97184
1-3/4"	3/8"	Hex	1	A-97190
2-9/16"	3/8"	Hex	1	A-97215
6"	3/8"	Hex	1	A-97237
1-3/4"	7/16"	Hex	1	A-97243
2-9/16"	7/16"	Hex	1	A-97259

El equipo estándar (accesorios), las especificaciones y las fotografías pueden variar. Los accesorios pueden no estar incluidos desde origen con las herramientas aunque se indiquen en este catálogo.

Puntas magnéticas Impact X



IMPACTX

Longitud	Medida	Tipo	Empaque piezas	No. Parte
1-3/4"	1/4"	Hex	1	A-97097
3/4"	1/4"	Hex	10	A-97106
6"	1/4"	Hex	10	A-97128
1-3/4"	5/16"	Hex	3	A-97651
1-3/4"	3/8"	Hex	3	A-97667

Puntas magnéticas Impact X



Longitud	Medida	Tipo	Empaque piezas	No. Parte
6"	1/4"	Hex	10	A-99459
1-3/4"	5/16"	Hex	10	A-97156
2-9/16"	5/16"	Hex	10	A-97178
6"	5/16"	Hex	10	A-99465
1-3/4"	3/8"	Hex	10	A-97209
2-9/16"	3/8"	Hex	10	A-97221
6"	3/8"	Hex	10	A-99471
1-3/4"	7/16"	Hex	10	A-99487
2-9/16"	7/16"	Hex	10	A-99493
6"	7/16"	Hex	10	A-99502

Juego de puntas magnéticas Impact X

Varias medidas



IMPACTX

* A-97639

Longitud	Medidas	Tipo	Empaque piezas	No. Parte
1-3/4"	1/4" - 5/16" - 3/8"	Hex	3	A-97265
1-3/4"	1/4" - 5/16" - 3/8" - 7/16"	Hex	4	A-97639
2-9/16"	1/4" - 5/16" - 3/8"	Hex	3	A-97689
6"	1/4" - 5/16" - 3/8"	Hex	3	A-97695

Juego de puntas Impact X

Varias medidas



IMPACTX

Contiene	Tipo	Empaque piezas	No. Parte
	1/4" Hex	35	A-98326
	1/4" Hex	40	A-98332
	1/4" Hex	50	A-98348

Punta para atornillar

Empaque (forma-C)



Tamaño	Longitud (mm)	Zanco tipo	Empaque piezas	No. Parte
Ph1, Ph2, Ph3	25	A	3	B-24511
Pz1, Pz2, Pz3	25	A	3	B-24527
T20, T25, T30	25	A	3	B-24533

Punta para atornillar

Empaque (forma-E)



Con magnético

Tamaño	Longitud (mm)	Zanco tipo	Empaque piezas	No. Parte
Ph1, Ph2, Ph3	50	1/4" Hex	3	B-26179
Pz1, Pz2, Pz3	50	1/4" Hex	3	B-26185
T20, T25, T30	50	1/4" Hex	3	B-26191



Punta plana para atornillar

Empaque (forma-E)



Con magnético

Tamaño	Longitud (mm)	Zanco tipo	Empaque piezas	No. Parte
Sl	0.5x4.0 x 25mm	1/4" Hex	3	B-23519
Sl	0.8x5.5 x 25mm	1/4" Hex	3	B-23531
Sl	1.0x5.5 x 25mm	1/4" Hex	3	B-23547
Sl	1.2x8.0 x 25mm	1/4" Hex	3	B-23569
Sl	3-4 x 25mm	1/4" Hex	3	B-24181
Sl	4-5 x 25mm	1/4" Hex	3	B-24197
Sl	8-10 x 25mm	1/4" Hex	3	B-24228
Sl	0.5x4.0 x 50mm	1/4" Hex	3	B-25286
Sl	0.8x5.5 x 50mm	1/4" Hex	3	B-25301
Sl	1.0x5.5 x 50mm	1/4" Hex	3	B-25317
Sl	1.2x8.0 x 50mm	1/4" Hex	3	B-25339
Sl	3-4 x 50mm	1/4" Hex	3	B-25878
Sl	4-5 x 50mm	1/4" Hex	3	B-25884
Sl	8-10 x 50mm	1/4" Hex	3	B-25915



Punta para atornillar Caja flip top

Forma-C



Tamaño	Longitud (mm)	Zanco tipo	Empaque piezas	No. Parte	
Pz1, Pz2, Pz3	Pz1	25	A	25	B-24608
	Pz2	25	A	25	B-24614
	Pz3	25	A	25	B-24620
T15, T20, T25, T30	T15	25	A	25	B-24636
	T20	25	A	25	B-24642
	T25	25	A	25	B-24658
	T30	25	A	25	B-24664

Caja flip top (forma-E)



Con magnético

Tamaño	Longitud (mm)	Zanco tipo	Empaque piezas	No. Parte	
Pz1, Pz2, Pz3	Pz1	50	MZ-B	10	B-26266
	Pz2	50	MZ-B	10	B-26272
	Pz3	50	MZ-B	10	B-26288
T15, T20, T25, T30	T15	50	MZ-B	10	B-26294
	T20	50	MZ-B	10	B-26303
	T25	50	MZ-B	10	B-26319
	T30	50	MZ-B	10	B-26325

Minivitolero (forma-C)



Tamaño	Longitud (mm)	Zanco tipo	Empaque piezas	No. Parte
Ph2	25	A	100	B-24876
Sq2	25	A	100	B-24898

ACCESORIOS

Minivitolero (forma-E)



Con magnético



Tamaño	Longitud (mm)	Zanco tipo	Empaque Piezas	No. Parte	
+	Ph2	50	MZ-B	50	B-26490
□	Sq2	50	MZ-B	50	B-26515

Bolsa de plástico (forma-C)



Tamaño	Longitud (mm)	Zanco tipo	Empaque piezas	No. Parte	
+	Ph2	25	A	100	B-24957
□	Sq2	25	A	100	B-24979

Bolsa de plástico (forma-E)



Con magnético



Tamaño	Longitud (mm)	Zanco tipo	Empaque piezas	No. Parte	
+	Ph2	50	MZ-B	50	B-26571
□	Sq2	50	MZ-B	50	B-26593

Caja flip top tipo Phillips(forma C)



Tamaño	Longitud (mm)	Tipo	Empaque piezas	No. Parte	
+	Ph1X1"	25	MZ-B	25	B-24577
	Ph2X1"	25	MZ-B	25	B-24583
	Ph3X1"	25	MZ-B	25	B-24599
	Ph1X2"	50	MZ-B	10	B-26238
	Ph2X2"	50	MZ-B	10	B-26244
	Ph3X2"	50	MZ-B	10	B-26250
	Phillips doble #2 2-9/16"	65	NZ-C	100	D-31647
	Phillips doble #2 2-9/16"	65	NZ-C	100	D-31669
	Ph2x1"	25	NZ-C	250	784211A250
	Ph2x1"	25	NZ-C	250	784312A250

Set de puntas de ajuste para atornilladores y atornilladores de impacto

Cuando utilice una punta para atornillar o punta socket, revise sus dimensiones (A) o (B). Cuando sus dimensiones de 11mm y 9.5mm respectivamente, instale esta punta en su herramienta.

No. Parte
322279-6

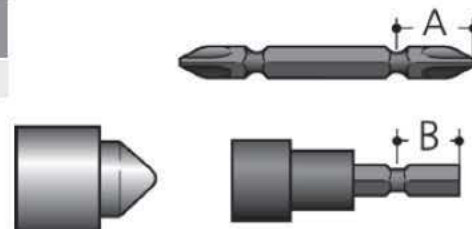

Accesorios para atornilladores

Boquillas para atornillador de tablaroca



Usar en	Boquilla tipo	Medida	Empaque piezas	No. Parte
6801DBV	Boquilla de tope	1/4"	1	411292-0
6802BV	Boquilla de tope	3/8"	1	122212-6
6802BV	Boquilla de tope	5/16"	1	122213-4
6820V	Boquilla de tope	3/8"	1	122450-0
6827	Tapa frontal de dado	3/8"	1	322119-8
6827	Tapa frontal de dado	5/16"	1	322125-3
6827	Tapa frontal de dado	1/4"	1	322124-5
6827	Tapa frontal de dado	7/16"	1	322126-1
6827	Tapa frontal de dado	5/16"	1	322120-3
6826	Localizador	1/4"	1	152483-1

Eje flexible

Extensión flexible para atornillado en esquinas y en lugares de difícil acceso



Longitud	Zanco	Tipo	No. Parte
12"		Eje flexible	B-51873

Adaptador magnético

Longitud	Zanco	Tipo	No. Parte
2 3/8"	1/4"	Adaptador magnético hexagonal tipo broquero	B-52473
2 3/8"		Adaptador magnético	B-52451
6"		Adaptador magnético	B-57750
12"		Adaptador magnético	B-57776

El equipo estándar (accesorios), las especificaciones y las fotografías pueden variar. Los accesorios pueden no estar incluidos desde origen con las herramientas aunque se indiquen en este catálogo.

Juegos de puntas para atornillar con dado magnético (MZ)

12 piezas



Contenido	No. Parte
<ul style="list-style-type: none"> Ph1, Ph2, Ph3 x 25mm Pz1, Pz2, Pz3 x 25mm T10, T15, T20, T25, T30 x 25mm 	<p>D-31083</p> <p>* D-31083-12 Empaque con 12 juegos</p>

Juego de puntas para atornillar con dado magnético (MZ)

12 piezas



Contenido	No. Parte
<ul style="list-style-type: none"> Ph1, Ph2, Ph3 x 25mm T15, T20, T25 x 25mm SI 3/16", SI 1/4" x 25mm Sq1, Sq2, Sq3 x 25mm 	<p>D-31619</p> <p>* D-31619-12 Empaque con 12 juegos</p>

Juego de puntas tipo T, 2" de longitud

18 piezas



Contenido	No. Parte
<ul style="list-style-type: none"> Ph1, 2xPh2, Ph3 x 25mm Pz1, 2xPz2, Pz3 x 25mm SI4, SI5, SI6 x 50mm 	B-28896
<ul style="list-style-type: none"> Ph2, 2x1", Pzs 8 Pz1, 1x2", Pz1 Pz3, 3x2", Pz1 SI4, 5, 6 Pzs 1 Adaptador hexagonal pzs. 1 	B-43000

Juegos de puntas para atornillar con dado magnético (MZ)

28 Piezas



Contenido	No. Parte
<ul style="list-style-type: none"> Ph0, Ph1, 3xPh2, Ph3 x 25mm Pz0, Pz1, 2xPz2, Pz3 x 25mm SI4, SI5, SI6 x 25mm T10, T15, T20, T25, T27, T30, T40 x 25mm H2, H2.5, H3, H4, H5, H6 x 25mm 	B-28911

Juegos de puntas para atornillar con dado magnético (MZ)

30 piezas



Contenido	No. Parte
<ul style="list-style-type: none"> 2xPh1, 4xPh2, 1xPh3 2xPz1, 5xPz2, 1xPz3 SI 4.0, SI5.5, SI6.5 2xT10, 2xT15, 2xT20, 3xT25, 2xT30, 1xT40 	<p>D-30667</p> <p>* D-30667-12 Empaque con 12 juegos</p>

Juegos de puntas phillips

Para todos los modelos de atornilladores inalámbricos



Tamaño	Longitud	Empaque piezas	No. Parte
	#2	4-5/16"	Pack 10 Pzs. D-34849
	#2	2-9/16"	Pack 10 Pzs. D-34366

Juego de puntas

Para madera y metal
17 piezas



Contenido	No. Parte
Brocas y puntas varias medidas, varias longitudes	D-31762

Puntas magnéticas (guías buscadoras)



Usar en	Tipo	Medida	Longitud	Empaque piezas	No. Parte
Todos los modelos de atornillador	Dado	1/4"	1-3/4"	1	784819-A
Todos los modelos de atornillador	Dado	5/16"	2-3/16"	1	784820-A
Todos los modelos de atornillador	Dado	5/16"	2-3/16"	1	784804-5
Todos los modelos de atornillador	Dado	7/16"	2-3/16"	1	784805-3
Todos los modelos de atornillador	Dado	1/4"	2-3/16"	1	784803-7
Todos los modelos de atornillador	Dado	3/8"	2-3/16"	1	784802-9
Todos los modelos de atornillador	Dado	3/16", 1/4", 5/16", 11/32", 3/8", 7/16", 1/2"	2-3/16"	Juego 8 piezas	*785501-AA
6826	Sujetador magnético	1/4"	2-3/16"		784807-9
6826	Dado	5/16"x3/8"	2-3/16"	1	785508-A
6911D	Dado	3/8"	2-3/16"	1	785509-A
6911D	Dado	7/16"x3/8"	2-3/16"	1	785510-A
6911D	Dado	1/2"x3/8"	2-3/16"	1	785511-A

Puntas magnéticas (guías buscadoras) 1-7/8"

6,8,10,12,13mm (Para todos los modelos de atornillador)



Medida: pulgadas

Medida	Longitud	Tipo	Empaque piezas	No. Parte
1/4"	1-7/8"	MZ	1	B-38794
5/16"	1-7/8"	MZ	1	B-38803
3/8"	1-7/8"	MZ	1	B-38819
7/16"	1-7/8"	MZ	1	B-38825
1/2"	1-7/8"	MZ	1	B-38831
1/4"	2-3/16"	MZ	1	784801-1
1/4"	2-3/16"	MZ	1	784811-8

Porta puntas (llavero)



Zanco	Piezas por empaque	No. Parte
MZ 1/4"	1	B-54411

Puntas magnéticas (guías buscadoras) 2-9/16"



Medida	Longitud	Tipo	Empaque piezas	No. Parte
1/4"	2-9/16"	MZ	1	B-45076
5/16"	2-9/16"	MZ	1	B-45082
3/8"	2-9/16"	MZ	1	B-45098
7/16"	2-9/16"	MZ	1	B-45107

Guía buscadora transparente

Descripción	Longitud	Empaque Piezas	No. Parte
 1/4"	4-3/4"	1	B-52940
Guía buscadora + Juego de puntas (25 piezas) Ph1-1"x5 Ph2-1"x5 Ph3-1"x5 S15-1"x5 S16-1"x5	3-1/8"	25	B-49890
 Guía buscadora + Juego de puntas (25 piezas) Ph1-1"x5 Ph2-1"x5 Ph3-1"x5 S15-1"x5 S16-1"x5	4-3/4"	25	B-49909

Estuche de plástico

Para guardar accesorios

Contenido	Tamaño (mm)	Empaque piezas	No. Parte
Estuche de plástico	Mediano (150x102x44)	1	B-62072

El equipo estándar (accesorios), las especificaciones y las fotografías pueden variar. Los accesorios pueden no estar incluidos desde origen con las herramientas aunque se indiquen en este catálogo.

Juego de Autoclear con matraca y 20 accesorios



Contenido	Empaque piezas	No. Parte
Puntas para atornillar 25mm, zanco Hex 1/4" PH1, PH2, PH3, PZ1, PZ2, T20, T25, T30, HEX4, HEX6, SL 0.8x5.5, SL 1.2x6.5 (1pza. c/u) Adaptador de cuadro 1/4", 60mm (1pza.) Porta puntas magnético 60mm, zanco Hex 1/4" (1pza.) Minillave de matraca 100mm (1pza.) Dados 5.0, 6.0, 8.0, 10.0, 12.0, 13.0 (1pza c/u)	21	B-54081

Juego de dados de impacto con cuadro de 3/8" y adaptador 1/4" Hex. (9pzs)



Diámetro	Longitud (mm)	No. Parte
3/8"	8mm, 10mm, 12mm, 13mm, 14mm, 15mm, 17mm, 18mm	B-54651

Adaptador con cuadro de 3/8" para llave de impacto



*Para DTW800

Cuadro	Zanco	Longitud	No. Parte
3/8"	1/4" Hex.		B-54667
3/8"	1/4" Hex.	150mm (6")	B-57738
3/8"	7/16" Hex.		B-59835 *

Juego de dados de impacto con cuadro de 1/2" y adaptador 1/4" Hex. (9pzs)



Diámetro	Longitud (mm)	No. Parte
1/2"	8mm, 10mm, 12mm, 13mm, 14mm, 15mm, 17mm, 18mm	B-54645

Adaptador con cuadro de 1/2" para llave de impacto



* Para DTW800

Cuadro	Zanco	Longitud	No. Parte
1/2"	1/4" Hex. (MZ)		B-54673
1/2"	1/4" Hex.	150mm (6")	B-57744
1/2"	7/16" Hex.	150mm (6")	B-59841 *

Extensión con cuadro de 1/2" para llave de impacto

Cuadro	Zanco	Longitud	No. Parte
1/2"	1/4" Hex.	10"	B-55734
1/2"	1/4" Hex.	6"	B-55740
1/2"	1/4" Hex.	3"	B-55756

Adaptador con zanco SDS Plus (tipo broquero) para HR166D



Zanco	Longitud	No. Parte
SDS Plus	3 - 1/8"	B-59259

Guía buscadora



Descripción	Longitud	Empaque Piezas	No. Parte
 Guía buscadora	3-1/8"	1	B-48795
 Guía buscadora	4-3/4"	1	B-48804
 Guía buscadora + Juego de puntas (25 piezas) Ph2-1"x10, Sq2-1"x10, Sl8-10-1"x5	3-1/8"	25	B-48810
 Guía buscadora + Juego de puntas (25 piezas) Ph2-1"x10, Sq2-1"x10, Sl8-10-1"x5	4-3/4"	25	B-48826

Guía de atornillado 30mm con punta PH2



Contiene	Piezas por empaque	No. Parte
Guía de 30mm con punta PH2	1	D-61709

Juegos puntas magnéticas

Estuche con 43 piezas



Contiene	Piezas por empaque	No. Parte
	43	B-55697

Juegos de puntas magnéticas



Descripción	Piezas por empaque	No. Parte
Tipo dado: 1/4", 5/16", 3/8"	3	B-38847
Tipo dado: 1/4", 5/16", 3/8", 7/16"	4	B-38853

Dados magnéticos SDS Plus

Diámetro	Longitud	No. Parte
5/16" 3/8"	1-7/8"	B-59265
7/16" 1/2"		

Dados con cuadro de 1/2"



Diámetro	Longitud	No. Parte
3/8"	3-3/16"	A-96235
7/16"	3-3/16"	A-96241
1/2"	3-3/16"	A-96257
9/16"	3-3/16"	A-96263
5/8"	3-3/16"	A-96279
11/16"	3-3/16"	A-96285
3/4"	3-3/16"	A-96291
13/16"	3-3/16"	A-96300
7/8"	3-3/16"	A-96316
15/16"	3-3/16"	A-96322
1"	3-3/16"	A-96338
1-1/16"	3-3/16"	A-96344
1-1/8"	3-3/16"	A-96350
1-1/4"	3-3/16"	A-96366
1-3/16"	3-3/16"	A-96394

Juego de dados con cuadro de 1/2"



Diámetro	Longitud	No. Parte
7/16"	3-3/16"	A-96372
1/2"	3-3/16"	
9/16"	3-3/16"	
5/8"	3-3/16"	
11/16"	3-3/16"	
3/4"	3-3/16"	
13/16"	3-3/16"	
7/8"	3-3/16"	
15/16"	3-3/16"	
1"	3-3/16"	
1-1/16"	3-3/16"	
1-1/8"	3-3/16"	
1-3/16"	3-3/16"	
1-1/4"	3-3/16"	

El equipo estándar (accesorios), las especificaciones y las fotografías pueden variar. Los accesorios pueden no estar incluidos desde origen con las herramientas aunque se indiquen en este catálogo.

Degolladoras

Dados internos

	Usar en	Tipo	Diámetro	Longitud (mm)	Empaque Pieza	No. Parte
	6922NB	Interno	5/8"	36	1	764416-0
	6922NB	Interno	7/8"	39	1	764418-6
	6922NB	Interno	7/8"	85	1	764352-0
	6922NB	Interno	3/4"	38	1	764419-4
	6922NB	Interno	5/8"	36	1	764420-9
	6922NB	Interno	3/4"	84	1	764353-8
	6924N	Interno	1"	49	1	194312-2
	6924N	Interno	7/8"	49	1	194310-6
	6924N	Interno	1"	39	1	194311-4

Degolladoras

Dados externos

	Usar en	Tipo	Diámetro	Longitud (mm)	Empaque Pieza	No. Parte
	6922NB	Externo	5/8"	35	1	764362-7
	6922NB	Externo	3/4"	37	1	764361-9
	6922NB	Externo	7/8"	39	1	153909-6
	6922NB	Externo	3/4"	83	1	764363-5

Degolladoras

Dados externos

	Usar en	Tipo	Diámetro	Longitud (mm)	Empaque pieza	No. Parte
	6922NB	Externo	7/8"	85	1	764364-3
	6922NB	Externo	1"	49	1	194033-6
	6924N	Externo	7/8"	49	1	194092-0
	6924N	Externo	1"	49	1	194034-4
	6924N	Externo	7/8"	136	1	764382-1
	6924N	Externo	7/8"	226	1	764383-9
	6924N	Externo	1"	136	1	764380-5
	6924N	Externo	1"	226	1	764381-3

Broqueros cierre rápido



Usar en	Diámetro boca	Diámetro rosca	Detalle	Empaque piezas	No. Parte
BDF330D	3/8"	3/8"	Cierre rápido	1	766007-3
6041	3/8"	3/8"	Cierre rápido	1	763110-1
6260D	3/8"	3/8"	Cierre rápido	1	763185-0
6410	3/8"	3/8"	Cierre rápido	1	192016-0
6226DW	3/8"	3/8"	Cierre rápido	1	763180-0
BDA341, BDA351	3/8"	1/2"	Cierre rápido	1	766005-7
HP1351, HP1621	1/2"	1/2"	Cierre rápido	1	192692-0
BDF452, LXFD01, LXFD05, LXPH01, LXPH02, LXPH05	1/2"	1/2"	Cierre rápido	1	766008-1
6313D, 6333D	1/2"	1/2"	Cierre rápido	1	192891-4
6317D	1/2"	1/2"	Cierre rápido	1	193691-5
6311D	1/2"	3/8"	Cierre rápido	1	763103-8
6319D, 6339D, 6349D, 8414D, 8434D, 8444D, BDF454, BHP454	1/2"	3/8"	Cierre rápido	1	763191-5
	1/2"	3/8"	Cierre rápido	1	763193-1
MT064 (SSP)	3/8"	1/2"	Cierre rápido	1	763181-8

Broqueros estándar



Usar en	Diámetro boca	Diámetro rosca	Detalle	Empaque piezas	No. Parte
6501, MT650	1/4"	3/8"	Sin llave	1	763170-3
MDP303	3/8"	3/8"	Sin llave	1	763173-7
NHP1310	3/8"	3/8"	Con llave	1	195087-6
MT80B	1/2"	1/2"	Sin llave	1	766023-5
	1/2"	1/2"	Con llave	1	T-02820
	1/2"	1/2"	Cierre rápido	1	192664-5
6390D	1/2"	1/2"	Cierre rápido	1	763178-7
DS4010	1/2"	1/2"	Con llave	1	193822-6
DHP458			Cierre rápido	1	766015-4
HP1500, HP1620	1/2"	1/2"	Estándar con llave	1	195081-8
HP1500, HP1620	1/2"	1/2"	Röhm alemán con llave	1	T-01719
HP1500, HP1620	1/2"	1/2"	Jacobs USA	1	192541-1
DA4031	1/2"	1/2"	Con llave	1	193520-2
DA4511	1/2"	1/2"	Con llave	1	763062-6
HP1630	1/2"	1/2"	Con llave	1	763161-4
	3/8"	1/2"	Con llave	1	763174-5
DP4000	1/2"	1/2"	Con llave	1	763078-1
8422B	5/8"	1/2"	Con llave	1	763172-9
6016	5/8"	Cónico M16	Con llave	1	763011-3

Broqueros adaptadores



Usar en	Diámetro boca	Zanco	Detalle	Empaque Piezas	No. Parte
Modelos SDS-Plus	1/2"	Broquero estándar con adaptador SDS-plus	Incluye llave	2	194041-7
Adaptador con rosca para broqueros estándar 1/2" (usar con broquero 1950818, T-01719, 192541-1)				1	D-14093
Atornilladores inalámbricos	3/8"	Zanco Hex. 1/4"	Cierre rápido	1	763198-1
6914D	3/8"	Zanco Hex. 1/4"	Cierre rápido	1	192077-0

Broqueros SDS-Plus



Usar en	Diámetro boca	Diámetro rosca	Detalle	Empaque Piezas	No. Parte
HR2470	SDS-Plus	Inserción a flecha	Broquero de inserción rápida	1	194080-7
HR2810T, HR2811T	Estándar 1/2"	SDS-Plus	Juego para cambio rápido	1	194079-2

Llaves para broqueros



Usar en	Medida	Empaque piezas	No. Parte
Varios	1/4"	1	763442-6
DA301DW	3/8"	1	763415-9
Broquero Rhöm	1/2"	1	763441-8
Broquero Jacobs	1/2"	1	763434-5
		1	763427-2
6016	5/8"	1	763429-8
8419B	5/8"	1	763432-9
Varios	5/8"	1	763443-4

Socket fijador de varilla roscada



Tamaño	Empaque piezas	No. Parte
6mm	1	B-42961
8mm	1	B-42977
10mm	1	B-42983
6, 8, 10 mm	3	B-42999
3/8"	1	B-51611
1/2"	1	B-51627



Guía buscadora hexagonal hueca para espargos

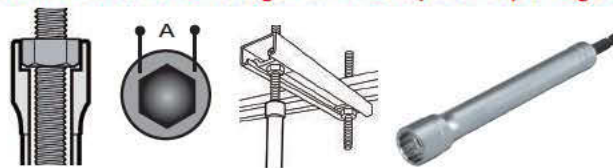

Tamaño socket	Longitud	Zanco tipo	No. Parte
7/16"	3"	MZ	B-50784
7/16"	6"	MZ	B-50790
7/16"	12"	MZ	B-50809
7/16"	18"	MZ	B-50815
7/16"	24"	MZ	B-50821
15/16"	3"	MZ	B-50837
15/16"	6"	MZ	B-50843
15/16"	12"	MZ	B-50859
15/16"	18"	MZ	B-50865
15/16"	24"	MZ	B-50871
9/16"	3"	MZ	B-43290
9/16"	6"	MZ	B-43309
9/16"	12"	MZ	B-43315
9/16"	18"	MZ	B-43321
9/16"	24"	MZ	B-43337
3/4"	3"	MZ	B-43343
3/4"	6"	MZ	B-43359
3/4"	12"	MZ	B-43365
3/4"	18"	MZ	B-43371
3/4"	24"	MZ	B-43387

El equipo estándar (accesorios), las especificaciones y las fotografías pueden variar. Los accesorios pueden no estar incluidos desde origen con las herramientas aunque se indiquen en este catálogo.

Set de brocas y puntas



ESTUCHES MAKIPAC

Innovador diseño de estuches apilables para una eficiente organización

1 Organización de Herramientas de trabajo

El innovador diseño de Makpac permite organizar, transportar y proteger herramientas y accesorios de trabajo.



2 Asa ergonómica

Asa corta y redondeada para mejor transporte y confort del usuario.



4 Broches a presión

Los broches a presión permiten cerrar bien el estuche, así como unir dos o más de estos y transportarlos fácilmente.

Carrito transportador de Makpac

Para apilar y transportar fácilmente los estuches con herramienta



No. Parte TR00000002



3 Tapa y ranuras

Tapa reforzada que proporciona durabilidad adicional, además de ranuras a lo largo del estuche que otorga estabilidad al apilar varios estuches.



Estuche Makpac 197210-9

Tamaño Pequeño
Dimensiones internas:
3"-15-1/4"x11-1/4"
Dimensiones externas:
4-3/8"x15-1/2"x11-5/8"
Peso: 1.3kg



Estuche Makpac 197211-7

Tamaño Mediano
Dimensiones internas:
5-1/8"x15-1/4"x11-1/4"
Dimensiones externas:
6-1/2"x15-1/2"x11-5/8"
Peso: 1.6kg



Estuche Makpac 197212-5

Tamaño Grande
Dimensiones internas:
7-1/4"x15-1/4"x11-1/4"
Dimensiones externas:
8-1/2"x15-1/2"x11-5/8"
Peso: 1.9kg



Estuche Makpac 197213-3

Tamaño Extra-grande
Dimensiones internas:
11-1/4"x15-1/4"x11-1/4"
Dimensiones externas:
12-1/2"x15-1/2"x11-5/8"
Peso: 2.4kg

Makita

ACCESORIOS

NUEVO

HIELERA MAKPACK



198307-7

198306-9

Para fácil transporte de bebidas frías, alimentos, etc.

Incluye correa para facilitar el transporte



Aislamiento térmico de 20mm de espesor



Se puede apilar con el resto de los estuches Makpack



Disponible en 2 tamaños para mayor comodidad



* Ambos modelos incluyen correa

198306-9

198307-7

Capacidad
Puede almacenar hasta 20 botellas de PET horizontalmente*

11L 198306-9 (Tipo 3)
500mL x 10 2L x 2

18L 198307-7 (* Tipo 4)
500mL x 20 2L x 4

Características	Código	
	198306-9 TIPO 3	198307-7 TIPO 4
Dimensiones (L x A x A)	295 x 395 x 210mm 11-5/8" x 15-1/2" x 8-1/4"	295 x 395 x 315mm 11-5/8" x 15-1/2" x 12-3/8"
Peso	2.9kg (6.3 lbs)	3.7kg (8.1 lbs)
Capacidad	11 lts (mediana)	18 lts (grande)



CARRITO TRANSPORTADOR DE ESTUCHES MAKIPAC

Ideal para transportar estuches Makipac

No parte:
TR00000002



Base plegable



Con correas integradas que permiten transportar con seguridad la mercancía

Botón para liberar o plegar el mango

Topes de Sujeción (laterales y frontal)
Brindan mayor sujeción de los estuches Makipac



Cuerpo de aluminio
que le brinda mayor resistencia

- Peso máximo**
- Superficies planas: 125Kg**
- Escaleras: 60Kg**
- Excelente maniobrabilidad**

El equipo estándar (accesorios), las especificaciones y las fotografías pueden variar.
Los accesorios pueden no estar incluidos desde origen con las herramientas aunque se indiquen en este catálogo.

Set de brocas y puntas

ACCESORIOS

Juego de accesorios multipropósito

Empaque con 17 piezas



Medidas en pulgadas tipo MZ

Contenido		Piezas	No. Parte
+	Ph2, Ph3	8 pzs	D-45836
+	Pz2, Pz3		
+	T20, T25		
+	SI 8.0, 1.2		
Broca HSS-R: 1/8", 3/16", 7/32", 1/4"		4 psz	
Broca para concreto: 3/16", 7/32", 1/4", 5/16"		4 psz	
Porta punta magnético		1 pz	

Juego de accesorios multipropósito

Empaque tipo tableta con 33 piezas



Juego de accesorios multipropósito Metal, concreto, madera

Empaque tipo tableta con 18 piezas



Medidas en pulgadas tipo MZ

Contenido	No. Parte
Broca HSS-G: 4mm, 5mm, 6mm, 7mm, 8mm, 10mm	B-49432
Broca p/concreto: 4mm, 5mm, 6mm, 7mm, 8mm, 10mm	
Broca p/madera: 4mm, 5mm, 6mm, 7mm, 8mm, 10mm	

Contenido		No. Parte
+	Ph1, Ph2, Ph3	B-49389
+	Pz1, Pz2	
+	SL 4.0, 6.0	
+	Atomillador	
Broca HSS-R: 2mm, 3mm, 3.3mm, 4mm, 4.2mm, 5mm		
Broca para concreto: 4mm, 5mm, 6mm, 7mm, 8mm		
Broca para madera: 3mm, 4mm, 5mm, 6mm, 7mm, 8mm		

Juego de accesorios multipropósito

Empaque con 34 piezas



Juego de accesorios multipropósito

Empaque con 30 piezas



Contenido		No. Parte
+	Ph1, Ph2, Ph3	D-47204
+	Pz1, Pz2, Pz3	
+	T20, T25, T30	
+	SL 4.0, 5.0, 6.0	
Broca HSS: 3mm, 4mm, 5mm, 6mm		
Broca p/concreto: 4mm, 5mm, 6mm, 8mm		
Broca para madera: 4mm, 5mm, 6mm, 8mm		
Avellanador p/metal		
Sujetador magnético p/puntas		



Medidas en pulgadas tipo MZ

Contenido		Piezas	No. Parte
Broca HSS-R	+	D-36980	
Broca p/concreto	+		
Broca p/madera	+		
Avellanadores	+		
Dado magnético	+		
Guía magnética	+		
T20, T25, T30		PZ1, PZ2, PZ3	
S1.0, S1.2, S1.5			
PH1, PH2, PH3			

ACCESORIOS

Set de brocas y puntas

Juego de accesorios multipropósito

Empaque con 42 piezas



Contenido	No. Parte
<ul style="list-style-type: none"> ⊕ Ph0, Ph1, Ph2, Ph3 ⊕ Pz1, Pz2, Pz3 ⊕ T10, T15, T20, T25, T27, T30, T40, T45 ○ H3, H4, H5, H6 <p>Broca para metal entrada Hex. 1/4", 2.5", 3.0", 4.0", 5.0", 6.0"</p> <p>Punta plana 0.5x4.0 1pz.</p> <p>Punta plana 0.8x5.5 1pz.</p> <p>Punta plana 1.2x6.5</p> <p>Dados 5, 6, 7, 8, 10, 11, 13mm</p> <p>Dado magnético</p> <p>Adaptador para dados</p> <p>Porta puntas</p>	D-58877

Juego de accesorios multipropósito

Empaque con 66 piezas



Contenido	No. Parte
<ul style="list-style-type: none"> ⊕ Ph1(x2), Ph2 (x8), Ph3 (x2) ⊖ SL 6-8 SL 8-10 SL 10-12 □ SQ1, SQ2 (x4), SQ3 ⊕ T10, T15, T20, T25, T27, T30, T40 <p>Brocas HSS-G 1/8", 9/64", 5/32", 3/16", 1/4"</p> <p>Brocas para madera 1/8", 3/16", 1/4", 5/16", 3/8"</p> <p>Brocas de manita Zanco Hex. 3/8", 1/2", 5/8"</p> <p>Adaptador magnético</p> <p>Adaptador c/sujeción</p> <p>Caja flip top (10pzs)</p> <p>Dados hexagonales</p>	B-51661

Juego de accesorios multipropósito

Empaque con 50 piezas



Contenido	No. Parte
<ul style="list-style-type: none"> ⊕ Ph1, Ph2 (x2), Ph3 <p>Brocas HSS 1, 5, 2, 2.5, 3, 3.5, 4, 4.5, 5, 5.5, 6, 6.5mm</p> <p>Brocas para concreto 4, 5, 6, 7, 8mm</p> <p>Brocas para madera 4, 5, 6, 8, 10mm</p> <p>Brocas de manita 16, 22mm</p> <p>Adaptador magnético</p> <p>Dados 7, 8, 10mm c/adaptador</p> <p>Cutter (con 2 cuchillas de repuesto)</p> <p>Calibrador de brocas</p>	D-42014

Juego de accesorios multipropósito

Empaque con 71 piezas



Contenido	No. Parte
<p>Puntas Forma C</p> <ul style="list-style-type: none"> ⊕ Ph1(x3), Ph2(x12), Ph3 (x3) ⊖ SL 6-8 SL 8-10 (X2) SL 10-12 □ SQ1(x3), SQ2(x12), SQ3 (x3) ⊕ T15, T20, T25, T27, T30 <p>Puntas Forma E</p> <ul style="list-style-type: none"> ⊕ Ph2 (x4) □ SQ1(x2), SQ2 (x4) <p>Brocas HSS-R 1/16", 5/64", 3/32", 7/64", 1/8", 9/64", 5/32", 3/16", 7/32", 1/4"</p> <p>Brocas de manita Zanco Hex. 1/4", 3/8", 1/2", 5/8", 3/4"</p> <p>Adaptador magnético</p>	B-50273

El equipo estándar (accesorios), las especificaciones y las fotografías pueden variar. Los accesorios pueden no estar incluidos desde origen con las herramientas aunque se indiquen en este catálogo.

Set de brocas y puntas

Juego de accesorios multipropósito

Empaque con 71 piezas



Contenido	No. Parte
<ul style="list-style-type: none"> ○ H3, H4, H5, H6x1" ● SL 6 SL7x1" SL4, SL6x2" ✦ PZ0, 1, 2, 3x1" / Pz1, Pz2, Pz3x2" ✦ T10, T15, T20, T25, T40 x1" T20, T25x2" <p>Brocas HSS Brocas HSS-Co Brocas de manita Adaptador magnético Dados 4,5, 6, 7, 8, 9, 10mm c/ adaptador Flexómetro 3m Calibrador de brocas, Avellanador, Tope de profundidad 1-10mm</p>	D-47145

Juego de accesorios multipropósito

Empaque con 75 piezas



Contenido	No. Parte
<p>Puntas Forma E - MZ</p> <ul style="list-style-type: none"> ✦ Ph1, Ph2, Ph3 ✦ T20, T25, T30, T40 ✦ Pz1, Pz2, Pz3 ○ H3, H4, H5, H6 <p>Puntas Forma C</p> <ul style="list-style-type: none"> ✦ Pz0, Pz1, Pz2 (x2), Pz3 ✦ PH0, PH1, PH2 (x2), PH3 ✦ T10, T15, T20, T25, T30 ● SL0.5x3 SL0.5x4 SL0.6x5 SL1x6 (x2) <p>Brocas HSS-TIN p/metal 1, 1.5, 2, 2.5, 3 (x2), 3.5, 4 (x2), 4.5 (x2), 5.5, 6, 6.5, 7, 7.5, 8 Brocas p/madera 4mm, 5mm, 6mm, 8mm Brocas HSS p/concreto 4mm, 5mm, 6mm, 7mm, 8mm Adaptador magnético Punzón 1/32" Avellanador 1/4" Dados 5mm, 5.5mm, 6mm, 7mm, 8mm, 9mm, 10mm, 11mm</p>	B-49373

ACCESORIOS

Juego de accesorios Makpac 96 pzs.

Empaque con 96 piezas



Contenido	No. Parte
<p>Puntas Forma C</p> <ul style="list-style-type: none"> ✦ T10, T15 (x2), T20 (x2), T25 (x2), T27, T30 (x2), T40 ● SL0.5x4, SL0.6x4.5, SL1x5.5, SL1x6.5 ✦ PH0, PH1, PH2 (x2), PH3 ✦ Pz0, Pz1, Pz2 (x2), Pz3 ○ H3, H4, H5, H6 <p>ST10, ST15, ST20, ST25, ST27, ST30, ST40</p> <p>Brocas HSS-G 3mm, 4mm, 5mm, 6mm, 8mm, 10mm Brocas para Madera 3mm, 4mm, 5mm, 6mm, 8mm, 10mm Broca concreto 3mm, 4mm, 5mm, 6mm, 8mm, 10mm Guía magnética 1/4" Zanco Hex. Atornillador tipo matraca Mini atornillador manual Cutter</p>	B-49725

Juego de accesorios multipropósito

Empaque con 100 piezas



Contenido	No. Parte
<p>Puntas Forma C</p> <ul style="list-style-type: none"> ✦ T10, T15, T20 (x2), T25 (x2), T30, T40 ● SL4 (x2), SL5 (x2), SL5.5 (x2), SL6.5 (x2) ✦ PH0 (x2), PH1 (x2), PH2 (x3), PH3 (x3) ✦ Pz0 (x2), Pz1 (x2), Pz2 (x3), Pz3 (x3) ○ H3, H4, H5, H6 <p>Puntas Forma E</p> <ul style="list-style-type: none"> ✦ PH1, PH2, PH3 ● SL5.5, SL6.5 ✦ Pz1, Pz2, Pz3 ○ H3, H4, H5, H6 ✦ T20, T25, T30, T40 <p>Brocas HSS 1.5, 2, 2.5, 3, 3.2, 3.5, 4, 4.5, 5, 5.5, 6, 6.5mm Brocas para Madera 3mm, 4mm, 5mm, 6mm, 7mm, 8mm, 10mm Broca concreto 3mm, 4mm, 5mm, 6mm, 8mm, 10mm Brocas de manita 16, 20, 25mm Adaptador magnético 1/4" hex Avellanador Zanco Hex. Dados magnéticos zanco Hex. 6, 8, 10, 11, 12, 13mm Tope de profundidad 3, 5, 8, 10mm Calibrador de brocas</p>	D-47248

ACCESORIOS

Set de brocas y puntas

Juego de accesorios multipropósito Edición de aniversario

Empaque con 100 piezas



Contenido	No. Parte
<p>Puntas p/atornillar 25mm</p> <ul style="list-style-type: none"> T10, T15 (x2), T20 (x2), T25 (x2), T27, T30 (x2), T40 SL0.5x4, SL0.6x4.5, SL1x5.5, SL1.2x6.5 PH0, PH1, PH2 (x2), PH3 <p>Puntas p/atornillar 25mm Edición especial</p> <ul style="list-style-type: none"> PH0 (x2), PH1(x2), PH2 (x3), PH3(x3) Pz0 (x2), Pz1(x2), Pz2 (x3), Pz3 (x3) T10, T15, T20, T25, T30, T40 <p>Brocas HSS 1/8", 9/64", 5/32", 3/16", 1/4"</p> <p>Brocas para Madera 1/8", 3/16", 1/4", 5/16", 3/8"</p> <p>Brocas de manita 3/8", 1/2", 5/8"</p> <p>Adaptador 1/4" zanco Hex.</p> <p>Adaptador magnético 1/4" zanco Hex.</p> <p>Puntas p/atornillar caja flip: PZ2(x5), PH2(x5)</p> <p>Dados magnéticos 1/4" zanco Hex: 1/4", 5/16", 3/8", 7/16", 1/2"</p>	<ul style="list-style-type: none"> H3, H4, H5, H6 Pz0, Pz1, Pz2 (x2), Pz3 ST10, ST15, ST20, ST25, ST27, ST30, ST40 SL0.8x4, SL1.0x5.5, SL1x6.0, SL1.2x6.5 H3, H4, H5, H6 <p style="font-weight: bold; font-size: 1.2em;">B-45375</p>

Juego de accesorios Makpac 116 pzs.

Empaque con 116 piezas



Contenido	No. Parte
<p>Juego de puntas c/ brocas para herramienta HSS-G</p> <p>Brocas HSS-G p/metal 1.5, 2, 2.5, 3, 3.2, 3.5, 4, 4.5, 5, 6mm</p> <p>Dados p/tornillos de cabezal hexagonal 4mm, 5mm, 6mm, 8mm, 10mm</p> <p>Puntas p/atornillador 25mm:</p> <ul style="list-style-type: none"> T10, T15 (x2), T20 (x2), T25 (x2), T30 (x2), T40 PH1 (x2), PH2 (x2), PH3 H5, H2.5, H3, H4, H5 (x2), H6 (x2) Pz1 (x2), Pz2 (x2), Pz3 S0 64.5 S0 85.5 S12 6.5 (x2) <p>Juego de brocas c/18 pzs con estuche</p> <p>Brocas HSS-G p/metal fresadas 1/8", 5/32", 3/16", 1/4", 5/16", 3/8"</p> <p>Brocas p/madera 1/8", 5/32", 3/16", 1/4", 5/16", 3/8"</p> <p>Brocas p/concreto (industriales) HMCT 1/8", 5/32", 3/16", 1/4", 5/16", 3/8"</p> <p>Dados p/tornillos de cabezal hexagonal 5mm, 6mm, 7mm, 8mm, 9mm, 10mm, 11mm</p> <p>Adaptador p/puntas tipo broquero</p> <p>Atornillador tipo matraca</p> <p>Atornillador manual tipo matraca</p> <p>Puntas p/atornillador 25mm:</p> <ul style="list-style-type: none"> PH1 (x2), PH2 (x2), PH3 (x2) Pz1 (x2), Pz2 (x2), Pz3 (x2) T10 (x2), T15 (x2), T20 (x2), T25 (x2), T30 (x2), T40 H2, H2.5, H3, H4 (x2), H5 (x2), H6 (x2) S0 6x4.5 (x2) S0 8x5.5 (x2) S1 2 x6.5 (x2) 	<p style="font-weight: bold; font-size: 1.2em;">B-49884</p>

Cajas apilables Makpac (sin accesorios)



Tamaño	No. Parte
Chica	197210-9
Mediana	197211-7
Grande	197212-5
Extra grande	197213-3

Hielera Makpac



Tamaño	No. Parte
11 lts Mediana	198306-9 (tipo 3)
18 lts Grande	198307-7 (tipo 4)

Carrito transportador de estuches Makpac

No parte:

TR0000002



Estuche de plástico para discos de diamante



Tamaño	Piezas empaque	No. Parte
150x145x130mm	1pz	D-63862

Cutter



Contenido	Piezas empaque	No. Parte
Cutter con 7 navajas de repuesto	1pz	D-58861

El equipo estándar (accesorios), las especificaciones y las fotografías pueden variar. Los accesorios pueden no estar incluidos desde origen con las herramientas aunque se indiquen en este catálogo.

Baterías, lámparas y cargadores



Sistema óptimo de carga

22min

Carga rápida con ventilador

El tiempo de carga en condición práctica

En caso de que la batería suba a 70°C justo después de usar en un ambiente de 25°C



Total 34 min



Total 70 min



Ventilador



Es necesario enfriar la batería antes de empezar a cargarla cuando la temperatura es alta después de usarla. Makita desarrolló el sistema original construido con ventilador de enfriamiento.

Enfriamiento bien balanceado

El diseño de flujo de aire eficiente, puede enfriar la celda de manera uniforme y rápidamente. El sistema de enfriamiento bien balanceado previene la carga solamente a una parte de la celda y provee larga vida a la batería.

Óptimo flujo de aire
MAKITA

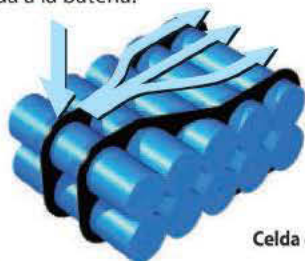

Celda de Batería



Competencia A
Enfriamiento desbalanceado
Salida de flujo de aire



Competencia B
Sin enfriamiento
Encerrado

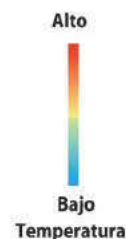

40% Ligero



MAKITA
18V Li-ion 3.0Ah
14.4V Li-ion 3.0Ah

MAKITA
18V /14.4V
Ni-MH 3.0Ah



Sujeción firme

Terminales multi-contacto reducen la resistencia e incrementan la conexión estable, además de soportar la vibración, asegurando una distribución de corriente estable para la herramienta.



430%

Resistencia extrema Tiempo de vida y volumen de trabajo



El cargador se comunica individualmente con la celda de la batería y controla la corriente, voltaje y temperatura. Carga rápida y óptima alcanzada, esto alarga la vida de la batería.

Cantidad total de energía de la vida útil de cada batería

Método tradicional de carga

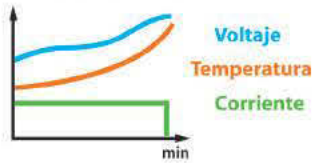

Carga óptima

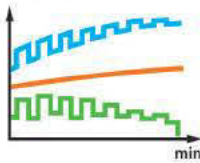

Li-ion 5.0Ah **710**

Li-ion 4.0Ah **570**

Li-ion 3.0Ah **430**

Ni-MH 2.8Ah **130**

Ni-Cd 1.9Ah **100**

Los números en la gráfica son valores relativos cuando la cantidad de Ni-cd 2.0Ah es indicada como 100.

Construida con chip de memoria

El chip de memoria de la batería registra la historia de la batería y se la transmite al cargador.



Comunicación digital



Construido con CPU

El CPU del cargador analiza su condición, alta temperatura y recarga después de una carga. Se alarga la vida de la batería porque esta puede ser cargada con el mejor método y tiempo.



Carga bien balanceada

MAKITA: Capacidad balanceada del paquete de la batería

1. Está diseñada para que una celda individual cuya condición está llena, descargue, o se vacíe bien. Es difícil que haya una descarga y una sobredescarga porque la capacidad de la celda individual lo previene
2. Esto es posible para usarlo con eficiencia porque la capacidad de la celda no es desigual y descarga uniformemente.

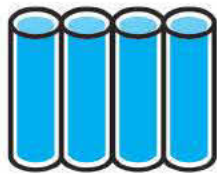

1. Carga completa

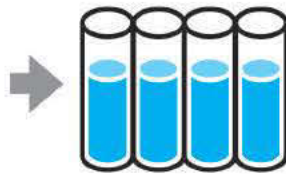

2. Descarga



1. Carga completa

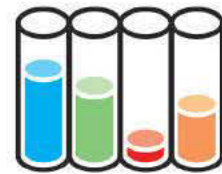

2. Descarga

Competencia A: Capacidad desbalanceada del paquete de batería

1. Sistema de carga de la competencia causa un decremento de la capacidad de la celda, debilitado por el trabajo pesado, porque la competencia no hace una carga óptima.
2. La descarga se detiene usando completamente la capacidad de la celda debilitada, cuando usted utiliza la herramienta en condición conocida como arriba se menciona. Por lo tanto, no utilizar las capacidades de otras celdas totalmente, por lo que las cargas de trabajo se disminuyen en una carga.

Carga en cualquier momento

Sin efecto de memoria
No requiere descarga



Absorbe impacto

Empaque de alto rendimiento



Largo almacenamiento

Baja autodescarga



Baterías y cargadores para un óptimo sistema de carga



Baterías y cargadores Li-ion 18V/14.4V

Tiempo de carga y compatibilidad

BATERÍZATE



Tecnología extrema de Litio-ion

Sistema de carga inteligente, la carga y descarga se hace completa, aumentando la vida útil de la batería, además de que el proceso de carga controla la corriente, el voltaje y la temperatura.

DC18RC BLISTER
(630714-3) A GRANEL



Multicargador de cuatro puertos
DC18SF
(196421-3) CAJA

DC18SD
(194529-7) CAJA



Multicargador de dos puertos
DC18RD (196963-7) CAJA
(630862-8) A GRANEL



DC18SE (Automotriz)
(194617-0) CAJA



* Excepto BL1430A

(sólo para conectar al encendedor del auto)

18V Lithium-ion		14.4V Lithium-ion				
6.0 Ah	 BL1860B (197422-4) CAJA DE CARTÓN			55 min.	230 min. 460 min.	230 min.
5.0 Ah	 BL1850B Ahora(632F15-1) A GRANEL Ahora(197282-4) BLISTER			45 min. Carga rápida	110 min. 1 a 2 baterías 220 min. 3 a 4 baterías	110 min.
4.0 Ah	 BL1840B BLISTER	Nivel de carga de la batería La energía restante de la batería puede ser indicada en 4 etapas, simplemente apretando un botón Modelos BL1860B, BL1850B, BL1840B y BL1830B		36 min. Carga rápida	90 min. 1 a 2 baterías 180 min. 3 a 4 baterías	90 min.
3.0 Ah	 BL1830B BLISTER (194205-3) A GRANEL	BL1430 (194065-3)BLISTER (638392-3) A GRANEL *BL1430A (194359-6) Tipo indicador de carga BL1430B (632G20-4)		22 min. Carga rápida	60 min. 1 a 2 baterías 120 min. 3 a 4 baterías	60 min.
2.0 Ah	 BL1820 BLISTER			24 min. Carga rápida	45 min. 1 a 2 baterías 90 min. 3 a 4 baterías	45 min.
1.5 Ah	 BL1815N (196449-1)	BL1415NA (196280-5) CAJA tipo indicador de carga		15 min. Carga rápida	30 min. 1 a 2 baterías 60 min. 3 a 4 baterías	30 min.
1.3 Ah	 BL1815 (638468-6) A GRANEL			15 min. Carga rápida	30 min. 1 a 2 baterías 60 min. 3 a 4 baterías	30 min.

Baterías y cargadores Li-ion y CXT

Tiempo de carga y compatibilidad

 **BATERÍZATE**

18V
Lithium-ion

1.3 Ah



BL1813G
(632B05-0)
A GRANEL

Para modelos:
DF457D, HP457D, JV183D, ML187, TD127D, UH422D,
UH482D, UH522D, UM167D, UR180D

1.1 Ah



BL1811G
(195453-7)
CARTÓN

Para modelos:
FD04, PH02, ML187, HU02, MU02, RJ02



DC18WA

60 min.

60 min.



Nivel de carga de la batería

La energía restante de la batería puede ser indicada en 4 etapas, simplemente apretando un botón (modelos **BL1021B** y **BL1041B**)



12V
Lithium-ion

1.5 Ah



BL1016
(197393-5)
(197413-5) BLISTER

2.0 Ah



BL1021B
(197414-3)

4.0 Ah



BL1041B
(197416-9) BLISTER



DC10SB
(197344-8)



DC10WD
(1973406)

22 min

Carga rápida

50 min

30 min

Carga rápida

70 min

60 min

Carga rápida

130 min

12V
Lithium-ion

1.3 Ah



BL1014
(638587-8) A GRANEL
(195332-9) ENCAPSULADO



DC10WB

50 min.

7.2V
Lithium-ion

1.3 Ah



BL7010
(194356-2) ENCAPSULADO



DC10WB

50 min.



DC07SA

30 min.

Baterías, cargadores y adaptadores Li-ion 36V

Tiempo de carga y compatibilidad

36V
Li-ion

Sistema de carga rápida



2.6Ah BL3626
(638645-0)

Tiempo de carga
22 min.



(630629-4)
DC36RA
Sólo para BL3626

Sistema de carga estándar



2.2Ah BL3622A
(195411-3)

Tiempo de carga
60 min.



con medidor de carga



(195468-4)
DC36WA
Sólo para BL3622A

36V
Lithium-ion

12.0
Ah



Tipo mochila BL36120A

DC3600



180
min.

Adaptador de batería
(opcional)



197727-2

Convertidor de batería BCV01 (opcional)

Para usuarios con 2 baterías de 18V BL1830 ó dos baterías BL1850, se pueden utilizar en herramientas inalámbricas de 36V con el convertidor de batería BCV01.



Con medidor de carga



18V x2

Para herramientas de 36V, utilizando el poder de dos baterías de 18V



BCV01 No es aplicable para desbrozadoras y cortadoras de cadena BBC231U/ BBC300L/ BC231UD/ BC300LD/ HRU01/ HXU01

Convertidor de batería BCV03 (opcional)

Para usuarios con 2 baterías de 18V BL1830 ó dos baterías BL1850, se pueden utilizar en herramientas inalámbricas de 36V con el convertidor de batería BCV03.



18V x2

Para herramientas de 36V, utilizando el poder de dos baterías de 18V



Con medidor de carga



Adaptador de batería BAP36N (opcional)

Permite separar la batería de la herramienta y así reducir el peso de esta, disminuyendo la fatiga de la mano y del brazo.



36V

Para herramientas con batería de 36V



BAP36N No es aplicable para desbrozadoras y cortadoras de cadena BBC231U/ BBC300L/ BC231UD/ BC300LD/ HRU01/ HXU01

Cuando baterías de diferentes capacidades son usadas juntas, por ejemplo una de 1.5Ah (BL1815N) y una de 3.0Ah (BL1830) ó una batería de 3.0Ah al 70% de carga y la otra de igual amperaje al 100%, la herramienta se detiene cuando la carga de la batería de menor capacidad se ha agotado.



KITS MAKPAC

Estuches Makpac con baterías y cargador de 12V deslizables y 18V Litio-ion

197665-8

1.5
Ah



Kit de estuche Makpac con baterías de **1.5Ah** y cargador (197649-6)
de NUEVA línea de baterías deslizables de 12V Litio-ion deslizable



BL1016
2 piezas



DC10SB

2.0
Ah



Kit de estuche Makpac con baterías de **2.0Ah** y cargador (197665-8)
de NUEVA línea de baterías deslizables de 12V Litio-ion deslizable



BL1021B
2 piezas



DC10SB

4.0
Ah



Kit de estuche Makpac con baterías de **4.0Ah** y cargador (197632-3)
de NUEVA línea de baterías deslizables de 12V Litio-ion deslizable



BL1041B
2 piezas



DC10SB

5.0
Ah



Kit de estuche Makpac con baterías de **5.0Ah** y cargador (197152-7)



BL1850
4 Piezas



DC18RD



ACCESORIOS

Baterías, lámparas y cargadores

Chegador de baterías



Descripción	Empaque pieza	No. Parte
Indispensable para revisar la vida útil de las baterías. Funciona con baterías Ni-Cd, Ni-Mh y Li-Ion hasta 24V. Incluye: chegador de baterías, adaptador para cargas de refresco, adaptador para baterías Ni-cd, software de instalación, cables de conexión a puerto p/ PC, maletín. Funciona con cargador DC245A, no incluido.	1	194090-4

Adaptadores

Descripción	Aplicación	Clave	Empaque Pieza	No. Parte
	Baterías Makstar 24V.	BAP24	1	193689-2
	Baterías Li-Ion 36V.	BAP36N	1	A-51225
		ADP03	1	193681-8
	Chegador de baterías 1940904		Juego 2 Piezas	194088-1
	Para baterías de 14.4V y 18V, Voltaje de salida: 5V	ADP05	1	ADP05

Accesorios para herramientas inalámbricas

Descripción	Usar en	Descripción	Empaque pieza	No. Parte
	BDF453	Empuñadura lateral	1	122822-9
	BC300LD	Guarda inferior para desbrozadora	1	140583-9
	UH5570	Gancho de seguridad para cable	1	158024-1
	BUB360	Correa de transporte	1	166095-4
	BDF330D	Funda para herramienta	1	168467-9

Descripción	Usar en	Descripción	Empaque pieza	No. Parte	
	5012B / BUC250	Aceite lubricante (repuesto)	1	182229-1	
	BHR2005	Extractor de polvo	1	193472-7	
	Baterías BL3626	Protector para batería 36V	1	194649-7	
	BTD146, BTD147, BDF458, BHP458	Protector contra polvo y agua p/ baterías BL1815 y BL1830	1	195798-3	
		Protector p/ baterías BL1430	1	456336-9	
	BTD133, BTD134, BTD135, BTD136, BTD145, BTD146, BTD147, BTP130, BTP140, BTS130, BTW152	BDF440, BDF444, BDF445, BDF450, BDF454, BHP440, BHP444, BHP450, BHP454, BTD130F	1	195927-8	
		Atornilladores de impacto	Amarrador de estructuras	1	194731-2
	BFH040/F/090/120F	Cubierta anti-impacto		1	195231-5
	BJS130	Gancho para cinturón		1	281220-7
	BUC122	Cubierta de barra guía		1	416311-7
	BVR340 / 850	Seguro		1	417383-5
	BTD120	Cubierta transparente de plástico		1	417476-8
	6796FD, 6797FD, 6798FD, BFT120/F, BFT121F	Protector de goma para herramienta (rojo)		1	417605-3
	6796FD, 6797FD, 6798FD, BFT120/F, BFT121F	Protector de goma para herramienta (azul)		1	417615-0
	6796FD, 6797FD, 6798FD, BFT120/F, BFT121F	Protector de goma para herramienta (amarillo)		1	417616-8
	BFL080F	Protector de herramienta	1	418066-0	
	Todos los atornilladores	Cubre polvo (proteje al operador al efectuar perforaciones verticales)	1	421342-3	

El equipo estándar (accesorios), las especificaciones y las fotografías pueden variar. Los accesorios pueden no estar incluidos desde origen con las herramientas aunque se indiquen en este catálogo.

Accesorios para herramientas inalámbricas

	Usar en	Descripción	Empaque pieza	No. Parte
	BDA350	Sujetador de llave	1	450688-0
	TD144D	Porta herramienta	1	A-49884
	LXGC01Z	Kit de cartucho p/ calafateadora 800ml	1	197195-9

	Usar en	Descripción	Empaque pieza	No. Parte
	BHR242	Sistema de extracción de polvo DX01	1	139121
	BHR243	Sistema de extracción de polvo DX02		139129
	DCG180	Cartucho recargable p/ calafateadora 600ml	1	196352-6

Lámparas

Lámparas versátiles

ideales para iluminar cualquier lugar de trabajo acorde a sus necesidades



* Nota: las lámparas no contienen batería

	Descripción	Empaque pieza	No. Parte
	Lámpara 36V Lithio recargable	1	STEXBML360
	Lámpara 18V recargable	1	LXLM01
	Luz de trabajo LED alimentada por batería Litio-ion 18V, 14.4V y corriente alterna	1	DML805
	Lámpara 18V Lithium ion con clip para solapa o cinturón	1	BML803
	Lámpara 18V, 14.4V Lithium ion fluorescente	1	BML184 / DML184
	Lámpara 18V, 14.4V Veinte LEDs blancos de 0.5W y un solo LED de 1W	1	DML806
	Lámpara LED, CXT 12V, Litio-ion	1	ML103
	Lámpara LED, CXT 12V, Litio-ion	1	ML104

	Descripción	Empaque pieza	No. Parte
	Lámpara luminiscente 14.4V, 18V Hasta 3 horas de iluminación continua con batería Lithium-ion (BL1830), cabezal de aluminio que gira a 170 grados	1	LXLM04
	Lámpara 14.4 - 18V Lithium ion c/ cabeza multiposiciones	1	ML187
	Un solo LED de 1W para una iluminación brillante 18V, 14.4V	1	DML800
	Radio para lugar de trabajo con triple LED de luz de destello 1.4W 18V, 14.4V	1	LXRM01
	Lámpara automotriz 14.4V fluorescente	1	ML143
	Lámpara 14.4V (foco)	1	192753-6 192752-8 (ML140)
	Lámpara de mano cabeza móvil 4 posiciones 12V	1	183588-6 (ML120)
	Lámpara 10.8 / 12V (inalámbrica luz LED, diseño compacto)	1	ML100
	De dos funciones lámpara linterna 10.8 / 7.2V LED recargable	1	ML102
	Mini lámpara LED	1	D-41838
	Adaptador imán	1	GM00001714

Hojas de sierra



Diámetro interior



Rake



Punta embedded



Corte limpio



Larga vida



No. Dientes



Anillo



Silencioso



Corte extra limpio



PCD Tip



Ranura



Corte al hilo



M-Force



Recubierto



Afilado



Espesor



Corte transversal ó a contra hilo



Corte rápido



Trabajo pesado



Hoja de sierra de carburo de tungsteno

Forma del diente

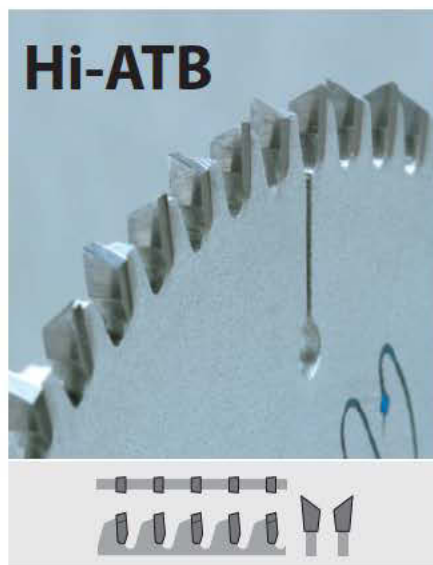
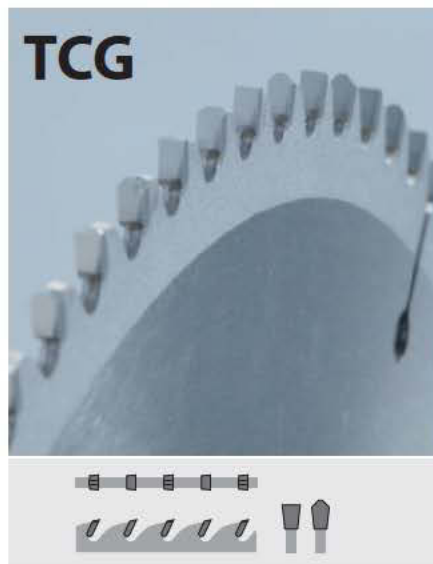
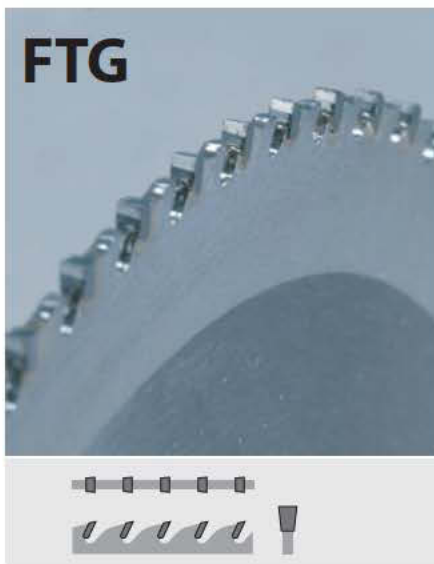
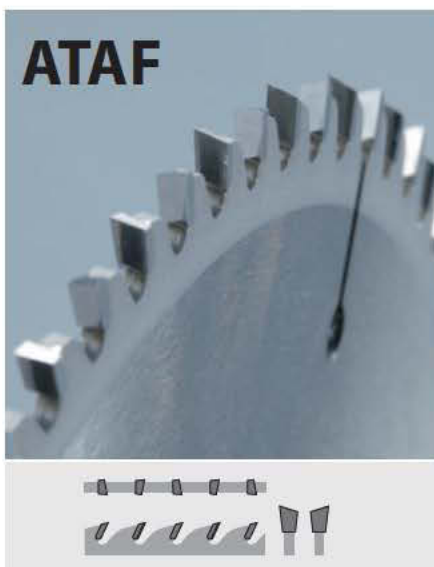
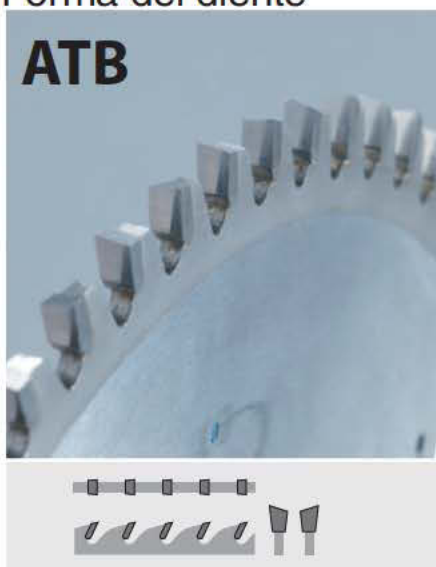

Término técnico

Hendidura laser

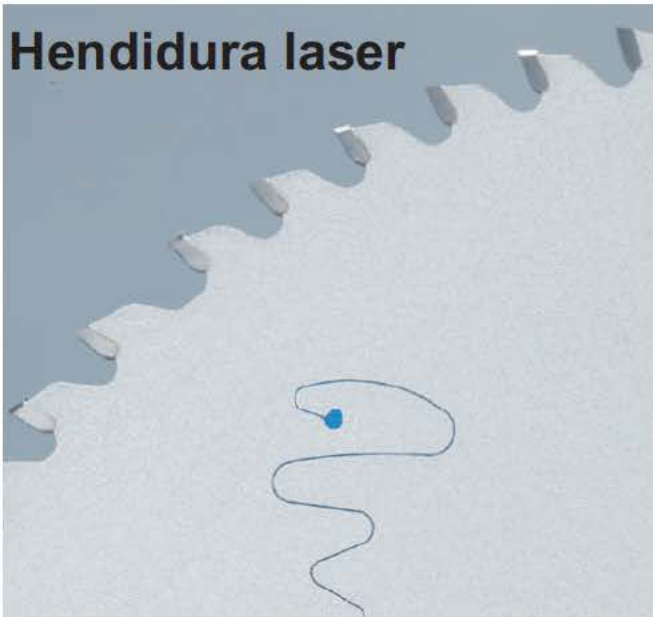

Sistema de oscilación de amortiguación Resinbond, llenos de ranuras láser del cuerpo para cortes más suaves y estables.

Cubierto



PTFE (pollytetrafluoroethylene) recubrimiento de Politetrafluoroetileno para reducir el calor y que no reaccione con otras sustancias químicas.

Punta incrustada



El diseño del diente insertado incrementa en gran medida el área de la soldadura de cuerpo -a- punta para un mayor apoyo y fuerza en punta.

Punta P.C.D.



PCD (Diamante Poly-Cristalizado) las pastillas son extremadamente fuertes con gran resistencia. Las pastillas PCD de los discos de corte son la mejor opción para un rendimiento de larga duración al cortar tableros de fibrocemento.

Especializado para corte silencioso

Línea estándar "Sierras manuales" Carburo de tungsteno

	Diámetro exterior (mm)	Perforación (mm- In)	Reductor (mm- In)	Grosor (mm)	Base (mm)	Dientes	Rastrillo	Forma del diente	Material	Nota	Piezas empaque	No. parte
	165 (6-1/2")	20mm	15.88(5/8")	1.45	1	44	5	TCG	Madera, MDF	Especial para DHS680RMI	1	B-53235
	165 (6-1/2")	20mm	15.88(5/8")	1.45	1	44	5	TCG	Madera	Especial para DHS680RMI	1	B-53241
	165 (6-1/2")	20mm	15.88(5/8")	1.45	1	56		ATAFR	Madera, MDF	Especial para SP600D	1	B-57370
	165 (6-1/2")	20mm	15.88(5/8")	2.2	1.6	48	8	ATB	Madera		1	B-07353
	165 (6-1/2")	20(3/4")	15.88(5/8")		1.2	24	12	ATB	Madera		1	D-51306
	165 (6-1/2")	20(3/4")	15.88(5/8")			64		ATAF	Madera	Especial para LS600D	1	B-56524
	165 (6-1/2")	20(3/4")	15.88(5/8")			60		TCT	Aluminio	Especial para LS600D	1	B-56574
	165 (6-1/2")	20(3/4")	15.88(5/8")	2	1.2	24	12	ATB	Madera		1	D-51312
	165 (6-1/2")	20(3/4")	15.88(5/8")	2	1.2	40	12	ATB	Madera		1	D-51328
	185 (7-1/4")	20(3/4")	15.88(5/8")	2.2	1.4	16	18	ATB	Madera		1	D-51334
	185 (7-1/4")	20(3/4")	15.88(5/8")	2.2	1.4	20	18	ATB	Madera		1	D-59106
	185 (7-1/4")	20(3/4")	15.88(5/8")	2.2	1.4	24	15	ATB	Madera		1	D-51340
	185 (7-1/4")	20(3/4")	15.88(5/8")	2.2	1.4	40	14	ATB	Madera		1	D-51356
	255 (10")	25.4mm	-	2.6	1.8	84		TCG	MDF		1	D-62452
	305 (12")	25.4mm	-			96		TCG	MDF		1	D-62468
	165 (6-1/2")	20mm	15.88(5/8")			52		TCG	MDF		1	D-62474
	255 (10")	25.4mm	-	2.8	1.8	84		TCG	MDF		1	D-62480
	305 (12")	25.4mm	-			96		TCG	MDF		1	D-62496

Sierra circular

	Diámetro exterior (mm)	Perforación (mm- In)	Reductor (mm- In)	Grosor (mm)	Base (mm)	Dientes	Rastrillo	Forma del diente	Material	Nota	Piezas empaque	No. parte
	185 (7-1/4")	15.88/5/8"		2	1.3	24	18	ATB	Madera		1	D-03436
	185 (7-1/4")	15.88/5/8"		2	1.3	40	18	ATB	Madera		1	D-20688
	210 (8-1/4")	15.88/5/8"		2	1.3	24	20	ATB	Madera		1	D-21521
	210 (8-1/4")	15.88/5/8"		2	1.3	40	15	ATB	Madera		1	D-31728
	210 (8-1/4")	15.88/5/8"		2.4	1.6	48	20	ATB	Madera		1	A-95934
	235 (9-1/4")	25.4(1")	25/15.88mm	2.5	1.6	20	14	ATB	Madera		1	D-51362
	235 (9-1/4")	25.4(1")	25/15.88mm	2.5	1.6	40	12	ATB	Madera		1	D-51378
	235 (9-1/4")	25.4(1")	25/15.88mm	2.5	1.6	60	12	ATB	Madera		1	D-51384

Sierra circular P/ aluminio

	Diámetro exterior (mm)	Perforación (mm- In)	Reductor (mm- In)	Grosor (mm)	Base (mm)	Dientes	Rastrillo	Forma del diente	Material	Nota	Piezas empaque	No. parte
	185 (7-1/4")	15.88/5/8"		-	-	40	-	TCG	Aluminio		1	D-62125

Línea estándar "Sierras manuales"

Empaque de 2 Y 3 Pzs.

	Diámetro exterior (mm)	Perforación (mm- In)	Reductor (mm- In)	Grosor (mm)	Base (mm)	Dientes	Rastrillo	Forma del diente	Material	Nota	Piezas empaque	No. parte
	185 (7-1/4")	1-3/16"	15.88mm-5/8"	2	1	16-20-40		ATB	Madera		1c/u 3Pzs	D-44769
	235 (9-1/4")	1-3/16"	15.88mm-5/8"	2.4	1.4	20-48-60		ATB	Madera		1c/u 3Pzs	D-44775
	185 (7-1/4")	1-3/16"	15.88mm-5/8"	2.2	1.6	24	25	ATB	Madera		1	D-59097
	235 (9-1/4")	25.4/1"	25mm-5/8"	2.4	1.6	24	25	ATB	Madera		1	B-19146
	235 (9-1/4")	25.4/1"	25mm-5/8"	2.4	1.6	40	25	ATB	Madera		1	B-19152
	235 (9-1/4")	25.4/1"	25mm-5/8"	2.4	1.6	60	20	ATAF	Madera		1	B-19168
	235 (9-1/4")	25.4/1"	25mm-5/8"	2.4	1.6	80	15	ATAF	Madera		1	B-19174
	235 (9-1/4")	25.4/1"	25mm-5/8"	2.4	1.6	40	18	ATB	Madera		1	D-03377
	235 (9-1/4")	30/1-3/16"	25.4mm 25mm-1"	2	1.6	20	20	ATB	Madera		1	D-03925

Sierra de banco

	Díámetro exterior (mm)	Perforación (mm- In)	Reductor (mm- In)	Grosor (mm)	Base (mm)	Dientes	Rastrillo	Forma del diente	Material	Nota	Piezas empaque	No. parte
	255(10")	25.4/1"	25mm-5/8"	2.8	2.2	40	25	ATB	Madera		1	A-81496
	255(10")	25.4/1"	25mm-5/8"	2.8	2	60	20	ATAF	Madera		1	A-81505

Sierra de inglete compuesto/Sierra de inglete

	Díámetro exterior (mm)	Perforación (mm- In)	Anillo (mm)	Grosor (mm)	Base (mm)	Dientes	Rastrillo	Forma del diente	Material	Nota	Piezas empaque	No. parte
	255(10")	30/1-3/16"	25.4/15.88	2.3	1.8	40	5	ATB	Madera		1	B-19233
	255(10")	30/1-3/16"	25.4/15.88	2.3	1.8	60	5	ATB	Madera		1	B-19249
	255(10")	30/1-3/16"	25.4/15.88	2.3	1.8	80	5	ATB	Madera		1	B-19255
	255(10")	30/1-3/16"	25.4/15.88	2.3	1.8	100	5	ATB	Madera		1	B-19261
	305(12")	30/1-3/16"	25.4	2.3	1.8	60	5	ATB	Madera		1	B-19364

Sierras de banco línea industrial

	Díámetro exterior (mm)	Perforación (mm- In)	Anillo (mm)	Grosor (mm)	Base (mm)	Dientes	Rastrillo	Forma del diente	Material	Nota	Piezas empaque	No. parte
	255(10")	30/1-3/16"	25.4/15.88	2.8	2	24	25	ATB	Madera		1	B-19392
	255(10")	30/1-3/16"	25.4/15.88	2.8	2	30	25	ATB	Madera		1	B-19401
	255(10")	30/1-3/16"	25.4/15.88	2.8	2	36	25	ATB	Madera		1	B-19417
	255(10")	30/1-3/16"	25.4/15.88	2.8	2	40	25	ATB	Madera		1	B-19423
	255(10")	30/1-3/16"	25.4/15.88	2.8	2	48	20	ATAF	Madera		1	B-19439
	255(10")			2.4	1.8	60	20	ATAF	Madera		1	B-19445
	255(10")	30/1-3/16"	25.4/15.88	2.4	1.8	80	15	ATAF	Madera		1	B-19451
	305(10-1/4")	25		1.4	1	36		ATB	Madera		1	7920873
	255(10")		1-3/16"	2.3	2	80		ATB	Madera		1	B-03551
	305(12")		25.4/1"	2.3	1.8	60		ATB	Madera		1	B-03676
	305(12")	30/1-3/16"	25.4/1"	3	2.2	30	25	ATB	Madera		1	B-19489
	305(12")	30/1-3/16"	25.4/1"	3	2.2	36	25	ATB	Madera		1	B-19495
	305(12")	30/1-3/16"	25.4/1"	3	2.2	40	25	ATB	Madera		1	B-19504
	305(12")	30/1-3/16"	25.4/1"	3	2.2	48	20	ATAF	Madera		1	B-19510
	305(12")	30/1-3/16"	25.4/1"	2.8	2	60	20	ATAF	Madera		1	B-19526
	305(12")	30/1-3/16"	25.4/1"	2.8	2	80	15	ATAF	Madera		1	B-19532

Sierras de banco

	Díámetro exterior (mm)	Perforación (mm- In)	Anillo (mm)	Grosor (mm)	Base (mm)	Dientes	Rastrillo	Forma del diente	Material	Nota	Piezas empaque	No. parte
	255(10")	30/1-3/16"	25.4/1" 15.88/5/8"	2.8	1.8	40	20	ATB	Madera	Hendidura láser	1	B-19467
	255(10")	30/1-3/16"	25.4/1" 15.88/5/8"	2.8	1.8	80	15	ATAFR	Madera	Hendidura láser	1	B-19473
	305(12")	30/1-3/16"	25.4/1"	2.8	1.8	48	20	ATB	Madera	Hendidura láser	1	B-19548
	305(12")	30/1-3/16"	25.4/1"	2.8	1.8	100	15	ATAFR	Madera	Hendidura láser	1	B-19554

Punta especializada para corte de clavos

Sierra circular

	Díámetro exterior (mm)	Perforación (mm- In)	Anillo (mm)	Grosor (mm)	Base (mm)	Dientes	Rastrillo	Forma del diente	Material	Nota	Piezas empaque	No. parte
	185(7-1/4")	20	15.88/5/8"	1.85	1.25	16	25	ATB	Madera	Punta incrustada	1	B-19118
	185(7-1/4")	20	15.88/5/8"	1.85	1.25	20	25	ATB	Madera	Punta incrustada	1	B-19124
	185(7-1/4")	20	15.88/5/8"	1.85	1.25	40	25	ATB	Madera	Punta incrustada	1	B-19130
	185(7-1/4")	5/8"	15.88/5/8"	1.2	1	24		ATB	Madera		1	A-94530
	185(7-1/4")	5/8"	15.88/5/8"	1.8	1.2	36		TCG	Madera		1	A-98778

El equipo estándar (accesorios), las especificaciones y las fotografías pueden variar. Los accesorios pueden no estar incluidos desde origen con las herramientas aunque se indiquen en este catálogo.

Especializado para corte silencioso

A batería

	Díámetro exterior (mm)	Perforación (mm- In)	Anillo (mm)	Grosor (mm)	Base (mm)	Dientes	Rastrillo	Forma del diente	Material	Nota	Piezas empaque	No. parte
	3-3/8"	15mm	n/a	1.1	1	50		ATB	Plástico		1	792299-8
	3-3/8"	15mm	n/a	1	1	24		ATB	Madera		1	721005A
	4"	7/8"	n/a	1.2	1	6		ATB	Madera		1	A-95118
	4-3/8"	20mm	n/a	1.8	1.2	24		ATB	Madera		1	A-81359
	4-3/8"	20mm	n/a	1	0.9	20	18	ATB	Madera		1	792010-8
	4-3/8"	20mm	n/a	1.8	1.2	12	20	ATB	Madera		1	A-90093

Especializado para corte de melámina

Sierras de banco (*Delgados)

	Díámetro exterior (mm)	Perforación (mm- In)	Anillo (mm)	Grosor (mm)	Base (mm)	Dientes	Rastrillo	Forma del diente	Material	Nota	Piezas empaque	No. parte
	250(10")	30 1-3/16"	25.4/15.88	3.2	2.2	80	5	TCG	Madera/MDF	Con cubierta Hendidura láser	1	B-39263
	300(12")	30 1-3/16"	25.4/1"	3.2	2.2	96	5	TCG	Madera/MDF	Con cubierta Hendidura láser	1	B-39279
	250(10")	30 1-3/16"	25.4/15.88	3.2	2.2	80	-5	Hi-ATB	Madera/MDF	Con cubierta Hendidura láser	1	B-39285
	300(12")	30 1-3/16"	25.4/1"	3.2	2.2	96	-5	Hi-ATB	Madera/MDF	Con cubierta Hendidura láser	1	B-39291
	185 (7 1-4")	20mm							Madera/MDF	Con cubierta Hendidura láser	1	D-61466
	250(10")	30 1-3/16"	25.4/15.88	2.6	1.8	80	5	TCG	Madera/MDF	Con cubierta Hendidura láser	1	B-42606*
	300(12")	30 1-3/16"	25.4/1"	2.6	1.8	96	5	TCG	Madera/MDF	Con cubierta Hendidura láser	1	B-42612*
	250(10")	30 1-3/16"	25.4/15.88	2.6	1.8	80	-5	Hi-ATB	Madera/MDF	Con cubierta Hendidura láser	1	B-42628*
	300(12")	30 1-3/16"	25.4/1"	2.6	1.8	96	-5	Hi-ATB	Madera/MDF	Con cubierta Hendidura láser	1	B-42634*

Especializado para corte de aluminio estándar

Sierra circular Mod. CA5000

	Díámetro exterior (mm)	Perforación (mm- In)	Anillo (mm)	Grosor (mm)	Base (mm)	Dientes	Rastrillo	Forma del diente	Material	Nota	Piezas empaque	No. parte
	118(4-1/2")	20	15.88 /5/8"			6		TCG	Aluminio	90°	1	B-48832
	118(4-1/2")	20	15.88 /5/8"			6		TCG	Aluminio	135°	1	B-48860

Sierra circular

	Díámetro exterior (mm)	Perforación (mm- In)	Anillo (mm)	Grosor (mm)	Base (mm)	Dientes	Rastrillo	Forma del diente	Material	Nota	Piezas empaque	No. parte
	185(7-1/4")	15.88(5/8")		2.2	1.5	40	5	FTG	Aluminio		1	D-03464
	235(9-1/4")	20	15.88 /5/8"	2.4	1.8	80	0	TCG	Aluminio		1	B-19722

Sierra de inglete compuesto /sierra de inglete

	Díámetro exterior (mm)	Perforación (mm- In)	Anillo (mm)	Grosor (mm)	Base (mm)	Dientes	Rastrillo	Forma del diente	Material	Nota	Piezas empaque	No. parte
	255(10")	15.88(5/8")		2.8	.2	70	0	TCG	Aluminio		1	D-19059
	255(10")	15.88(5/8")		2.3	1.8	80	-5	TCG	Aluminio		1	A-93887
	255(10")	15.88(5/8")		2.8	.2	100	-3	TCG	Aluminio		1	D-19065
	255(10")	15.88(5/8")		2.3	1.8	100	-5	TCG	Aluminio		1	A-93893
	255(10")	1-3/16"		2.4	1.8	100		TCG	Aluminio		1	D-19788
	255(10")	15.88 (5/8")		2.4	1.8	100		TCT	Aluminio		1	D-61896
	255(10")	15.88 (5/8")		2.4	1.8	100		TCT	Aluminio		1	D-61905

Sierra de inglete compuesto/sierra de inglete

	Díámetro exterior (mm)	Perforación (mm- In)	Anillo (mm)	Grosor (mm)	Base (mm)	Dientes	Rastrillo	Forma del diente	Material	Nota	Piezas empaque	No. parte
	305(12")	30 1-3/16"	25.4 /1"	2.3	1.8	80	-5	TCG	Aluminio		1	B-19766
	305(12")	30 1-3/16"	25.4 /1"	2.3	1.8	100	-5	TCG	Aluminio		1	B-19772

Especializado para corte de aluminio estándar

Sierra de banco

	Diámetro exterior (mm)	Perforación (mm-In)	Anillo (mm)	Grosor (mm)	Base (mm)	Dientes	Rastrillo	Forma del diente	Material	Nota	Piezas empaque	No. parte
	305(12")	30/1-3/16"	25.4/1"	2.6	2	100	0	ATB	Aluminio		1	B-19794
	305(12")	30/1-3/16"	25.4/1"	2.6	2	120	0	ATB	Aluminio		1	B-19803

Sierra de inglete compuesto /sierra de inglete

	Diámetro exterior (mm)	Perforación (mm-In)	Anillo (mm)	Grosor (mm)	Base (mm)	Dientes	Rastrillo	Forma del diente	Material	Nota	Piezas empaque	No. parte
	305(12")	25.4(1")		3	2.2	80	5	TCG	Aluminio		1	D-03486
	305(12")	25.4(1")		2.3	1.8	80	-5	TCG	Aluminio		1	A-93902
	305(12")	25.4(1")		2.3	1.8	100	-5	TCG	Aluminio		1	A-93918

Para panel de aluminio compuesto

	Diámetro exterior (mm)	Perforación (mm-In)	Anillo (mm)	Grosor (mm)	Base (mm)	Dientes	Rastrillo	Forma del diente	Material	Nota	Piezas empaque	No. parte
									Aluminio		1	A-96132

Especializado para corte de metal

Cortadora circular de metal

	Diámetro exterior (mm)	Perforación (mm-In)	Anillo (mm)	Grosor (mm)	Base (mm)	Dientes	Rastrillo	Forma del diente	Material	Nota	Piezas empaque	No. parte
	150(6")	20	15.88(5/8")	1.8	1.5	32	0	MTCG	Metal		1	B-47195
	150(6")	20	15.88(5/8")	1.8	1.5	52	0	ATB	Lámina de metal		1	B-47204
	150(6")	20	15.88(5/8")	1.8	1.5	60	0	SMTCG	Inox		1	B-47210
	150(6")	20	15.88(5/8")	1.8	1.5	52	0	CTG	Aluminio		1	B-47226
	185(7-1/4")	20	15.88(5/8")	1.9	1.5	36	0	ATB	Acero dulce		1	B-33912
	185(7-1/4")	20	15.88(5/8")	2	1.6	38	0	MTCG	Acero dulce		1	B-33928
	185(7-1/4")	20	15.88(5/8")	2	1.6	48	0	MTCG	Acero dulce delgado		1	B-33934
	185(7-1/4")	20	15.88(5/8")	1.7	1.3	70	-10	FTG	Base de acero corrugado		1	B-33940
	185(7-1/4")	20	15.88(5/8")	1.85	1.5	48	0	SMTCG	Acero dulce	Larga vida	1	B-23341
	185(7-1/4")	20	15.88(5/8")	1.8	1.5	56	0	SMTCG	Acero dulce delgado	Larga vida	1	B-23385
	185(7-1/4")	20	15.88(5/8")	1.6	1.3	64	0	SMTG	Acero inoxidable Acero dulce	Hendidura Láser	1	B-31681

Especializado para corte de metal

Cortadora de metal 12"

	Diámetro exterior (mm)	Perforación (mm-In)	Anillo (mm)	Grosor (mm)	Base (mm)	Dientes	Rastrillo	Forma del diente	Material	Nota	Piezas empaque	No. parte
	305(12")	25.4(1")		2.5	2.2	60	0	TCG	Acero dulce		1	A-90532
	305(12")	25.4(1")		2.1	1.7	60	0	TCG	Acero dulce		1	B-33956
	305(12")	25.4(1")		2.4	2.2	60	0	TCG	Acero dulce	Hendidura Láser	1	B-33962
	305(12")	25.4(1")		2.3	2	78	-5	MTCG	Acero dulce delgado		1	B-33978
	305(12")	25.4(1")		1.95	1.65	100	-3	SMTCG	Acero inoxidable Acero dulce	Hendidura Láser	1	B-23145
	305(12")	25.4(1")		1.8	1.2	76	0	TCG	Acero inoxidable Acero dulce		1	A-91039

Cortadora de metal 14"

	Diámetro exterior (mm)	Perforación (mm-In)	Anillo (mm)	Grosor (mm)	Base (mm)	Dientes	Rastrillo	Forma del diente	Material	Nota	Piezas empaque	No. parte
	355(14")	25.4(1")		2.2	1.8	70	0	TCG	Metal		1	B-51281
	355(14")	25.4(1")		2.1	1.8	90	-5	MTCG	Metal suave		1	B-51297

El equipo estándar (accesorios), las especificaciones y las fotografías pueden variar. Los accesorios pueden no estar incluidos desde origen con las herramientas aunque se indiquen en este catálogo.

Especializado para corte de MDF

Sierra circular

	Diámetro exterior (mm)	Perforación (mm- in)	Anillo (mm)	Grosor (mm)	Base (mm)	Dientes	Rastrillo	Forma del diente	Material	Nota	Piezas empaque	No. parte
	185(7-1/4")	30/1-3/16"	16-5/8" 20-3/4"	2.4	1.5	60	12	ATB	MDF		1	D-38934
	185(7-1/4")	20mm	16-5/8" 20-3/4"	2.2	1.5	60	12	ATB	MDF		1	D-59427
	185(7-1/4")	20mm		1.45	1	24	12	ATAFR	Madera	Para sierras circulares inalámbricas	1	B-62038
	190mm (7-1/2")		15.88mm (5/8")	1.45	1	44		TCG	MDF	Para sierras circulares inalámbricas de 7-1/2"	1	B-54461
	190mm (7-1/2")		15.88mm (5/8")	1.45	1	44		TCG	Madera	Para sierras circulares inalámbricas de 7-1/2"	1	B-54477

Sierra de inglete compuesto/Sierra de inglete

	Diámetro exterior (mm)	Perforación (mm- in)	Anillo (mm)	Grosor (mm)	Base (mm)	Dientes	Rastrillo	Forma del diente	Material	Nota	Piezas empaque	No. parte
	255(10")	30/1-3/16"	15.88/5/8"	3	2	100	12	ATB	MDF		1	D-38940
	305(12")	30/1-3/16"	15.88/5/8"	3.2	2.2	120	12	ATB	MDF		1	D-38956

Especializado para fibro cemento

Sierra circular

	Diámetro exterior (mm)	Perforación (mm- in)	Anillo (mm)	Grosor (mm)	Base (mm)	Dientes	Rastrillo	Forma del diente	Material	Nota	Piezas empaque	No. parte
	7-1/4"	5/8"		1.6	1	28		ATB	Fibro-cemento		1	A-90451

Anillos reductores para discos de sierra



Usar en	Eje disco	Reducción	Espeor	Empaque piezas	No. Parte
Discos para sierra 10"	1"	5/8"		1	257060-5
Discos para sierra 10"	1"	5/8"		1	257022-3
Discos para sierra 10"	3/4"	5/8"	1.2mm	1	B-20987
Discos para sierra 10"	3/4"	5/8"	1.8mm	1	B-20993
Discos para sierra 10"	1-3/16"	5/8"	1.2mm	1	B-21004
Discos para sierra 10"	1-3/16"	5/8"	1.8mm	1	B-21010
Discos para sierra 10"	1-3/16"	3/4"	1.2mm	1	B-21026
Discos para sierra 10"	1-3/16"	3/4"	1.4mm	1	B-21032
Discos para sierra 10"	1-3/16"	3/4"	1.8mm	1	B-21048
Discos para sierra 10"	1-3/16"	25mm	1.6mm	1	B-21054
Discos para sierra 10"	1-3/16"	1"	1.4mm	1	B-21060
Discos para sierra 10"	1-3/16"	1"	2.2mm	1	B-21076

Cera lubricante para discos metálicos y sierras de banda

Facilita el corte al disminuir a resistencia entre los materiales

Tipo	Empaque piezas	No. Parte
BpB180, 2016, 2106W, 2107F Discos para sierra con carburo de tungsteno y metálicos	Tubo 50gr.	191897-9



Seguetas



118° borde de cincel



135° Punta dividida



HSS-R



HSS-G



Alta velocidad cobalto 5%



M-force



Estaño alta velocidad



Para martillos SDS-plus



Punta de carburo de tungsteno



Utilice refrigerante



No perfora con impacto

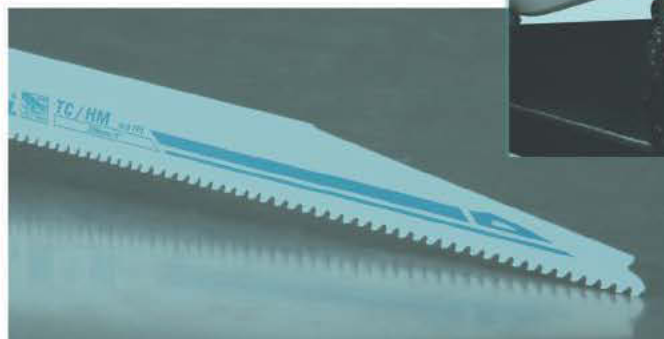
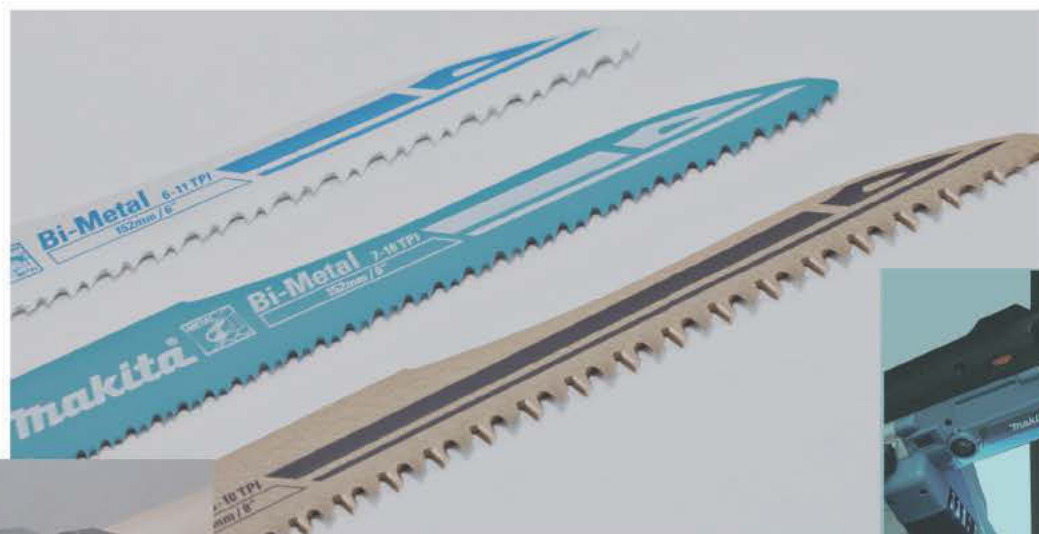

Segueta

Diente tipo

Dientes fresados corte libre triscado

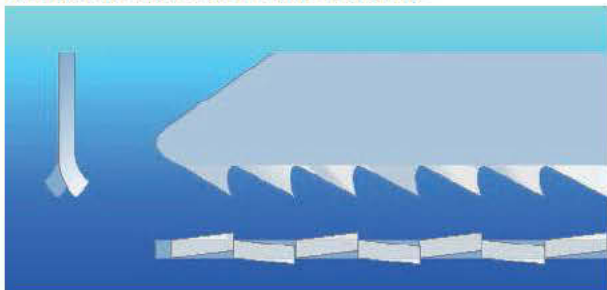

Dientes afilados corte libre triscados



Dientes fresados corte libre ondulado

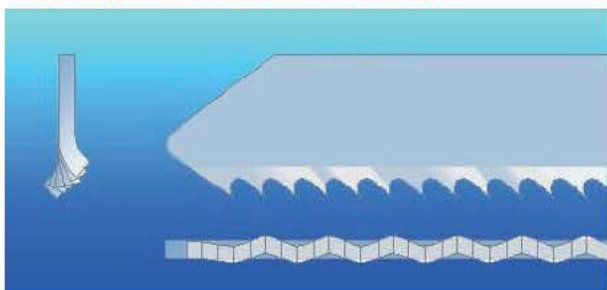

Dientes afilados corte libre afilado en ángulo libre

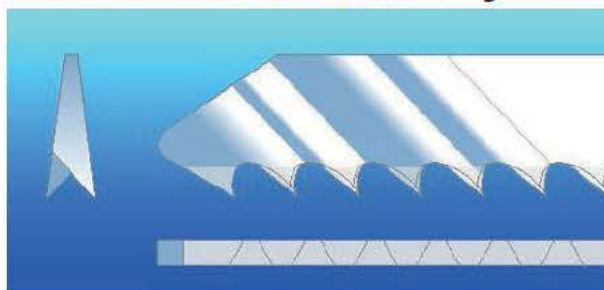

Fabricación de dientes

Dientes

- Bajo costo en el tipo de manufactura
- Para cortes en general
- Suave para materiales duros
- Larga vida de la segueta



Dientes para suelo

- Costo del tipo de manufactura
- Muy fuerte
- Corte preciso y limpio
- Suave para materiales de dureza media



Método de producción

- **Juego lateral:** Cada diente es alternado individualmente a la izquierda y a la derecha. Ejemplo de configuración: derecha, izquierda, recta, etc.
- **Juego ondulado:** La fila de dientes tiene forma de onda
- **Suelo:** El cuerpo de la segueta se estrecha en la parte posterior (cónico)



Juego lateral

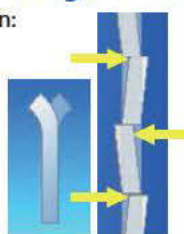

Juego ondulado: Suelo

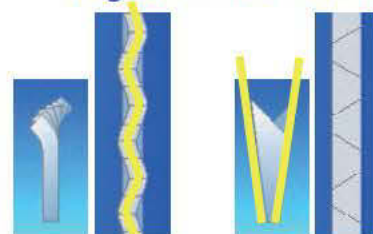

Segueta

- **HCS (Acero al alto carbón)** para corte de materiales suaves como madera o plásticos.
- **HSS (acero de alta velocidad)** para corte de materiales duros tales como metales.
- **BiM (Bi-Metal, HCS base y dientes HSS)** para corte de materiales suaves a duros como madera, metal, plásticos.
- **TC (Carburo de tungsteno)** para corte de fibra de vidrio reforzada de plástico, planchas de fibrocemento o yeso.

Segueta - encastre tipo B

Para modelos:

DJV181, DJV182, DJV141, DJV142, BJV180, BJV140, JV183D, JV143D, JV0600, JV100D, DJR185, DJR145, JR102D, 4326, 4327, 4328, 4329, 4350T/CT/FCT, 4351T/CT/FCT



Sierra de calar super-express

Forma	No.	Madera contrachapada (mm)	Plásticos (mm)	Aluminio (mm)	Acero inoxidable (mm)	Acero dulce (mm)	Características de la aplicación	Longitud de trabajo (mm)	Dientes por in	Material	Tipo de corte	Piezas empaque	No. parte
	B-50	B-50	B-50	-	-	-	Para trabajos de acabado en madera y plástico	77	8.5 -10.6	HCS		5	B-06460
	B-51	-	-	-	1-3	1-8	Para cortes en acero dulce, acero inoxidable	77	9.8 -18.1	HSS		5	B-06476
	B-52	5-50	5-50	3-35	3-5	3-8	Para corte universal de materiales	77	5.5 -9.8	HSS		5	B-06482

Madera/ básico

Forma	No.	Madera contrachapada (mm)	Plásticos (mm)	Aluminio (mm)	Acero inoxidable (mm)	Acero dulce (mm)	Características de la aplicación	Longitud de trabajo (mm)	Dientes por in	Material	Tipo de corte	Piezas empaque	No. parte
	B-13	4-65	4-65	-	-	-	Para cortes en general	70	8	HCS		5	A-85656
	B-15	3-35	3-35	-	-	-	Ideal para corte de materiales delgados	50	12	HCS		5	A-85678
	B-14	2-35	2-35	-	-	-	Ideal para corte de materiales delgados	50	18	HCS		5	A-85662
	B-18	2-35	2-35	-	-	-	Para cortes curvos	45	14	HCS		5	A-85709

Madera/ corte rápido

Forma	No.	Madera contrachapada (mm)	Plásticos (mm)	Aluminio (mm)	Acero inoxidable (mm)	Acero dulce (mm)	Características de la aplicación	Longitud de trabajo (mm)	Dientes por in	Material	Tipo de corte	Piezas empaque	No. parte
	B-58	4-65	4-65	-	-	-	Para corte rápido	75	8	HCS		5	A-86577
	B-16	5-65	5-65	-	-	-	Para corte rápido y basto	75	6	HCS		5	A-85684
	B-17	5-60	5-60	-	-	-	Ángulo del gancho 2°	70	6	HCS		5	A-85690
	B-17	4-65	4-65	-	-	-	Ángulo del gancho 2°	75	8	HCS		5	A-85232

Madera/ finalización

Forma	No.	Madera contrachapada (mm)	Plásticos (mm)	Aluminio (mm)	Acero inoxidable (mm)	Acero dulce (mm)	Características de la aplicación	Longitud de trabajo (mm)	Dientes por in	Material	Tipo de corte	Piezas empaque	No. parte
	B-17	4-65	4-65	-	-	-	Para trabajo de corte rápido y limpio	75	8	HCS		5	A-86583
	B-10	3-65	3-65	-	-	-	Para trabajo de acabado, especialmente en triplay	75	9	HCS		5	A-85628
	B-11	3-60	3-60	-	-	-	Para trabajos de acabado en madera y plástico	75	9	HCS		5	A-85634
	B-12	5-65	5-65	-	-	-	Trabajos de acabado en madera y plásticos	75	6	HCS		5	A-85640
	L-1	5-90	5-90	-	-	-	Ideal para cortes de materiales delgados	100	6	HCS		5	A-86290
	B-29	2-35	2-35	-	-	-	Para cortes curvos	42	16	HCS		5	A-80400
	BR-13	5-65	-	-	-	-	Cortes en madera que no requieren ser lijados	64	9	HCS		5	A-85793

El equipo estándar (accesorios), las especificaciones y las fotografías pueden variar. Los accesorios pueden no estar incluidos desde origen con las herramientas aunque se indiquen en este catálogo.

Trabajo duro/ chapas decorativas

Forma	No.	Madera contrachapada (mm)	Plásticos (mm)	Aluminio (mm)	Acero inoxidable (mm)	Acero dulce (mm)	Características de la aplicación	Longitud de trabajo (mm)	Dientes por In	Material	Tipo de corte	Piezas empaque	No. parte
	B-25	3-60	3-60	3-6	-	3-6	Para madera dura, hojas delgadas de acero dulce y plásticos duros	75	9	HSS		5	A-85765
	B-26	3-60	3-60	3-10	-	3-10	Para cortes curvos madera dura y plásticos duros	70	9	HSS		5	A-85771

Finalización de placas decorativas

Forma	No.	Madera contrachapada (mm)	Plásticos (mm)	Aluminio (mm)	Acero inoxidable (mm)	Acero dulce (mm)	Características de la aplicación	Longitud de trabajo (mm)	Dientes por In	Material	Tipo de corte	Piezas empaque	No. parte
	B-19	3-50	3-50	-	-	-	Dientes reversibles para cortes libres de astillas. Para plásticos duros y chapas decorativas	65	12	HCS		5	A-85715

Metal/ básico

Forma	No.	Madera contrachapada (mm)	Plásticos (mm)	Aluminio (mm)	Acero inoxidable (mm)	Acero dulce (mm)	Características de la aplicación	Longitud de trabajo (mm)	Dientes por In	Material	Tipo de corte	Piezas empaque	No. parte
	B-51	-	1.5-6	1.5-6	1-3	1-3	Para acero dulce	65	24	HSS		5	A-86561
	B-22	-	1-6	1-3	1-3	1-3	Para acero dulce, plásticos duros especialmente para lámina delgada de metal	50	24	HSS		5	A-85737
	B-24	-	1-3	1-2	0.5-2	0.5-2	Para metal muy delgado	50	32	HSS		5	A-85759
	B-23	3-35	3-35	2-6	-	2-6	Chapas decorativas, láminas de metal de grosor medio	50	14	HSS		5	A-85743
	B-27	-	1-6	1-3	1-3	1-3	Para cortes curvos en acero dulce	50	24	HSS		5	A-85787

Para MDF

Forma	No.	Madera contrachapada (mm)	Plásticos (mm)	Aluminio (mm)	Acero inoxidable (mm)	Acero dulce (mm)	Características de la aplicación	Longitud de trabajo (mm)	Dientes por In	Material	Tipo de corte	Piezas empaque	No. parte
	P	3-20	3-20	-	-	-	Especial para MDF y triplay larga vida	63	16	HSS	Recto	5	B-28709
	B-29	3-6	3-6	-	-	-	Especial para MDF y triplay	42	16	HSS	Curvo	5	B-28715
	B-28	3-20	3-20	-	-	-	Especial para MDF, triplay y madera enchapada corte fino	63	16	HSS	Recto	5	B-28721

Juego de seguetas Makita

Super cuchillo para sierra de calar













Tipo	5 diferentes hojas de sierra de calar en un paquete						Piezas empaque	No. parte
 Tipo B	B-10S	B-13	B-16	B-22	B-23	A-86898	5	
 Tipo B	B-50	B-51	B-52	-	-	B-06292	3	B-06292
 Tipo B	B-50x2	B-51	B-52	B-53	-	B-48527	5	

Para maderas básicas normales (línea estándar)

Para modelos:

DJV181, DJV182, DJV141, DJV142, BJV180, BJV140, JV183D, JV143D, JV0600, JV100D, DJR185, DJR145, JR102D, 4326, 4327, 4328, 4329, 4350T/CT/FCT, 4351T/CT/FCT

Forma	Madera contrachapada (mm)	Plásticos (mm)	Aluminio (mm)	Acero inoxidable (mm)	Acero dulce (mm)	Características de la aplicación	Longitud de trabajo (mm)	Dientes por in	Material	Tipo de corte	Piezas empaque	No. parte
	4-50	-	-	-	-	Madera /Básico	74	8	HCS		5	D-34877
	4-50	-	-	-	-	Madera / corte rápido	74	6	HCS		5	D-34883
	4-50	-	-	-	-	Madera / corte rápido, curvo	74	6	HCS		5	D-34899
	-	-	-	-	1-3	Metal / Básico		21	HSS		5	D-34908
	4-50	-	-	-	-	Madera / finalización	74	9	HCS		5	D-44214

Para plásticos

Forma	No.	Madera contrachapada (mm)	Plásticos (mm)	Aluminio (mm)	Acero inoxidable (mm)	Acero dulce (mm)	Características de la aplicación	Longitud de trabajo (mm)	Dientes por in	Material	Tipo de corte	Piezas empaque	No. parte
	B-21	-	3-60	1-10	-	-	Para trabajos de acabado en plásticos		12	HSS		5	A-85721

Para cemento de fibra

Forma	No.	Madera contrachapada (mm)	Plásticos (mm)	Aluminio (mm)	Acero inoxidable (mm)	Acero dulce (mm)	Características de la aplicación	Longitud de trabajo (mm)	Dientes por in	Material	Tipo de corte	Piezas empaque	No. parte
	B-60		-	-	-	-	Fibrocemento/yeso 5-50, FRP/plástico 5-20	75	6	TC	-	3	B-06890
	B-61		-	-	-	-	Fibrocemento/yeso 5-80, FRP/plástico 5-50	105	6	TC	-	3	B-06909

Sierra recíproca

Para madera y metal

Tipo	No.	Madera contrachapada (mm)	Aplicación	Material del diente	Piezas empaque /No. pieza	No. parte
	B-13	70	Para corte básico madera	HCS	2 A-85656	B-44410
	B-16	75	Para corte rápido madera	HCS	2 A-85684	
	B-10	65	Para corte fino madera	HCS	2 792691-8	
	B-22	50	Para corte básico metal	HSS	2 A-85737	
	B-23	50	Para corte básico metal	HSS	2 A-85743	

Para madera, metal, universal y laminado

Tipo	No.	Madera contrachapada (mm)	Aplicación	Material del diente	Piezas empaque /No. pieza	No. parte
	B-50	77	Para corte rápido/ fino madera	HCS	4 B-064640	B-44426
	B-51	77	Para corte rápido metal	HSS	2 B-06476	
	B-52	77	Para corte rápido universal	HSS	2 B-06482	
	B-53	60	Para corte fino laminado	BI-Metal	2 B-10970	





El equipo estándar (accesorios), las especificaciones y las fotografías pueden variar. Los accesorios pueden no estar incluidos desde origen con las herramientas aunque se indiquen en este catálogo.

Corte de metales y plásticos

Tipo	Dientes por in	Longitud total	Aplicación	Material	Piezas empaque	No. parte
	14 TPI	100(4")	Para corte en metales hasta 1/4" (6mm), conductos, portables, tuberías y canaletas	Bi-Metal	5	723062-A5
	10 TPI	100(4")	Para corte en metales y tuberías hasta 1/4" (6mm), conductos, madera con clavos, materiales compuestos, plásticos	Bi-Metal	5	723064-A5
	18 TPI	6-5/16"	Para corte en placa de acero de más de 3mm de espesor, tubo de hierro de 90mm ó menor	HCS	2	B-00810
	24 TPI	160mm	Placa de acero de 3mm ó menor, tubo de hierro de 50mm ó menor	HCS	2	B-00832

Para modelo: JR100D, JR102D

Para acero

Tipo	Dientes por in	Longitud total	Aplicación	Material	Piezas empaque	No. parte
	24	100(4")	Para metal de espesor de 0.7-3.0mm.	Bi-Metal	5	B-20395
	18	100(4")	Para metal de espesor de 1.5-4.0mm.	Bi-Metal	5	B-20404
	14	100(4")	Para metal de espesor de 3.0-8.0mm	Bi-Metal	5	B-20410
	24 TPI Acero al alto carbón	100(4")	Corte de lámina de acero hasta 3mm de espesor	(HCS)	2	B-00804
	18 TPI	82(3-1/2")	Cortes irregulares en metales hasta 1/8"	Bi-Metal	5	723061-A5

Para madera y acero

Tipo	Dientes por in	Longitud total	Aplicación	Material	Piezas empaque	No. parte
	10	100(4")	Para lámina de metal de 3.0-12.0mm, madera de 10.0-50.0mm	Bi-Metal	5	B-20426
	14-18	100(4")	Para metal de espesor de 3.0-8.0mm, madera de 10.0-50.0mm	Bi-Metal	5	B-20454

Para madera con clavos

Tipo	Dientes por in	Longitud total	Aplicación	Material	Piezas empaque	No. parte
	6	100(4")	Para madera con clavos 10.0mm-50.0mm	Bi-Metal	5	B-20432
	8-12 TPI	100(4")	Para madera con clavos, materiales compuestos, plásticos y metales	Bi-Metal	5	723059-A5

Para cartón yeso * Para JR300



Tipo	Dientes por in	Longitud total	Aplicación	Material	Piezas empaque	No. parte
	6	100(4")	Para tablaroca 5.0-50.0mm	Bi-Metal	5	B-20448
	6 TPI	100(6")	Cortes en yeso y tablaroca	Bi-Metal	5	723060-A5 *
	Varios	100(6")	Juego combinado	Bi-Metal	3	792003-5 *

Sierra recíproca



Para modelo:

JR140D, JR180D, BJR141, BJR181, BJR182, BJR240, JR3050T, JR3060T, JR3070CT





Para acero /básico

Tipo	Dientes por In	Longitud total (mm)	Aplicación	Material	Piezas empaque	No. parte
	18	165	Para lámina de acero, aluminio 3.0mm-5.0mm. Para tubo de hierro de 90 mm de diám. o menos	HSS	5	792147-1
	18	152	Para lámina de acero 1.5mm-3.0 mm. Para tubo de hierro de 100 mm de diám. o menos.	Bi-Metal	5	B-05169
	18	152	Para lámina de acero 1.5mm-3.0 mm. Para tubo de hierro de 100 mm de diám. o menos.	Bi-Metal	25	B-05169-25
	18	152	Corte de metal 1.5-4mm, tubería 5-100mm	Bi-Metal	2	D-51633
	24	152	Corte de metal 0.7-3mm, tubería 5-100mm	Bi-Metal	2	D-51649
	18	255	Corte de metal 1.5-4mm, tubería 5-175mm	Bi-Metal	2	D-51661
	24	255	Corte de metal 1.7-3mm, tubería 5-175mm	Bi-Metal	2	D-51677
	24	255	Corte de metal 0.7-3mm, tubería 5-175mm	Bi-Metal	5	B-43169
	10-94	255	Corte de metal 2-10mm, tubería 175mm	Bi-Metal	5	B-43197

Segueta sable flexible // Corte rápido, Para metal, larga vida

Tipo	Dientes por In	Longitud total (mm)	Aplicación	Material	Piezas empaque	No. parte
	14-18	152 (6")	Corte de metal	Bi-Metal	5	B-55815
	14-18	225 (9")	Corte de metal	Bi-Metal	5	B-55821
	14-18	305 (12")	Corte de metal	Bi-Metal	5	B-55837

Para madera con clavos

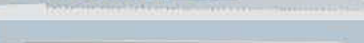
Tipo	Dientes por In	Longitud total (mm)	Aplicación	Material	Piezas empaque	No. parte
	6	152 (6")	Para madera con clavos 10mm-100mm, fibra de vidrio 8-50mm	Bi-Metal	5	B-05175
	10	152 (6")	Para tarimas, madera con clavos 5-100mm, hojas de metal, tubos, perfiles de aluminio 3-12mm	Bi-Metal	5	B-31843
	10	225 (9")	Para tarimas, madera con clavos 5-100mm, hojas de metal, tubos, perfiles de aluminio 3-12mm	Bi-Metal	5	B-31859
	14-18	225 (9")	Para tubos de automóvil	Bi-Metal	5	B-31865
	10-14	152 (6")	Corta metal, aluminio (3-10mm), pvc, madera c/ clavos (5-100mm)	Bi-Metal	5	B-43240
	10-14	225 (9")	Corta metal, aluminio (3-10mm), pvc, madera c/ clavos (5-175mm)	Bi-Metal	5	B-43262

El equipo estándar (accesorios), las especificaciones y las fotografías pueden variar.
Los accesorios pueden no estar incluidos desde origen con las herramientas aunque se indiquen en este catálogo.

Segueta sable flexible // Corte rápido, Para metal, larga vida

Tipo	Dientes por In	Longitud total (mm)	Aplicación	Material	Piezas empaque	No. parte
	14	152 (6")	Corte de metal 1.5-4mm, tubería 5-100mm	Bi-Metal	25	D-51627-25
	18	152 (6")	Corte de metal 1.5-4mm, tubería 5-100mm	Bi-Metal	25	D-51633-25

Sierra recíproca

Segueta sable para poliuretano, hule espuma

Tipo	Dientes por In	Longitud total (mm)	Aplicación	Material	Piezas empaque	No. parte
	1.5mm	6"	Para poliuretano y hule espuma	HCS	1	B-52118
	1.5mm	9"	Para poliuretano y hule espuma	HCS	1	B-52124
	1.5mm	12"	Para poliuretano y hule espuma	HCS	1	B-52130











Tipo	Dientes por In	Longitud total (mm)	Aplicación	Material	Piezas empaque	No. parte empaque	No. parte
Para madera y madera con clavos 			Para corte rápido (super express) madera		2	B-05153	B-44432
			Para corte básico madera		2	B-16798	
			Para madera con clavos		2	B-05175	
Para metal, universal 			Para corte rápido (super express) universal		2	B-05044	B-44448
			Para corte básico metal		2	B-16776	
	18	228mm	Para corte básico metal		2	B-16782	
Para madera con clavos 	Variado	152	Corta metal, madera juego c/ porta seguetas	Bi-Metal HCS	2	D-53089	D-53051
					2	D-51627	
					2	D-51633	

Sierra recíproca

Para modelo:

JR140D, JR180D, BJR141, BJR181, BJR182, BJR240, JR3050T, JR3060T, JR3070CT

Segueta para sierra sable super express

Tipo	Dientes por In	Longitud total (mm)	Aplicación	Material	Piezas empaque	No. parte
	7-18	152(6")	Para corte rápido de metal (hierro/acero 1.5-8.0mm, plástico 5-77mm)	Bi-Metal	5	B-05038
	7-18	152(6")	Para corte rápido de metal (hierro/acero 1.5-8.0mm, plástico 5-77mm)	Bi-Metal	25	B-05038-25
	6-11	152(6")	Corte rápido para metal no-ferroso, aluminio, plásticos, madera con clavo, acero (hierro/acero 5-8mm, plástico 5-77mm, madera 5-77mm)	Bi-Metal	5	B-05044
	6-11	152(6")	Corte rápido para metal no-ferroso, aluminio, plásticos, madera con clavo, acero (hierro/acero 5-8mm, plástico 5-77mm, madera 5-77mm)	Bi-Metal	25	B-05044-25
	6-10	203(8")	Corte rápido para madera	HCS	5	B-05153
	6-10	203(8")	Corte rápido para madera	HCS	25	B-05153-25
	18	225mm	Para corte básico metal	Bi-Metal	5	B-16782
	18	225mm	Para corte básico metal	Bi-Metal	25	B-16782-25
	24	225mm	Para metal y tubería delgada	Bi-Metal	5	B-16835
	6 TPI Alta velocidad	305(12")	Cortes rápidos y trabajos preparativos generales en madera sin clavos	HSS	5	723051-A5
	6 TPI BiMetal (Bim)	150(6")	Cortes rápidos y trabajos preparativos generales en madera	HCS		D-53089

Sierra recíproca

Para modelo:

JR140D, JR180D, BJR141, BJR181, BJR240, JR3050T, JR3060T, JR3070CT

Para material congelado (carne)

Tipo	Dientes por in	Longitud total (mm)	Aplicación	Material	Piezas empaque	No. parte
	3	305(12")	Para material congelado (Carne) 10-250 mm	Acero inoxidable	1	B-10609
	6	152(6")	Para material congelado (Carne) 10-80 mm	Acero inoxidable	1	B-52043
	6	228(9")	Para material congelado (Carne) 10-175 mm	Acero inoxidable	1	B-30564
	6	305(12")	Para material congelado (Carne) 10-250 mm	Acero inoxidable	1	B-23248
	10	228(9")	Para material congelado (Carne) 10-175 mm	Acero inoxidable	1	B-30570
	10	305(12")	Para material congelado (Carne) 10-250 mm	Acero inoxidable	1	B-23254

Para madera y acero

Tipo	Dientes por in	Longitud total (mm)	Aplicación	Material	Piezas empaque	No. parte
	5-8	305	Hormigón (10-250mm), plásticos/fibra de vidrio plástico reforzado, perfiles (5-60mm)	Bi-Metal	3	B-10637

Para uso especial

Tipo	Dientes por in	Longitud total (mm)	Aplicación	Material	Piezas empaque	No. parte
	-	152	Para lámina de acero inoxidable 2mm-4mm, tubo de acero inoxidable 50mm diám. o menos, fibra de vidrio	TC/HM	2	B-07250
	-	200	Tubo de acero inoxidable diámetro de hasta 3"	TC/HM	2	B-51312
	-	228	Tubo de acero fundido 150mm diámetro o menos para ladrillo rojo 10-175mm , FRP/ Epóxico 3-175mm	Grano de diamante	2	B-31871

Para bambú y rama verde

Tipo	Dientes por in	Longitud total (mm)	Aplicación	Material	Piezas empaque	No. parte
	8.5	190	Para ramas verdes, bambú; corte limpio	HCS	1	B-56580
	15	190	Para ramas verdes, bambú; corte limpio	HCS	1	B-56596
	8.5	225	Para ramas verdes, bambú; corte limpio	BIM	1	B-57386
	15	225	Para ramas verdes, bambú; corte limpio	BIM	1	B-57392
	8.5	250	Para ramas verdes, madera; corte limpio	HCS	1	B-62016

Segueta sable para madera y metal

Tipo	Dientes por in	Longitud total (in)	Aplicación	Material	Piezas empaque	No. parte
	6-8	6"	Labores de rescate, para madera, acero termotratado, material compuesto y cuerda de tornillo; sin chispas	TC	10	B-49834-10
	6-8	9"	Labores de rescate, para madera, acero termotratado, material compuesto y cuerda de tornillo; sin chispas	TC	10	B-49840-10
	6-8	12"	Labores de rescate, para madera, acero termotratado, material compuesto y cuerda de tornillo; sin chispas	TC	10	B-49856-10

Corte de ladrillo

Tipo	Dientes por in	Longitud total (mm)	Aplicación	Material	Piezas empaque	No. parte
	2 TPI carburo de tungsteno	12"	Para ladrillo, tabique y mampostería	2	1	B-10394
	2 TPI carburo de tungsteno	18"	Para ladrillo, tabique y mampostería	2	1	B-10403

Para tablaroca

Tipo	Dientes por in	Longitud total (mm)	Aplicación	Material	Piezas empaque	No. parte
	4Cs	2"	Para tablaroca	0.55	2	B-49703
	4Cs	2"	Para madera	0.55	2	B-49719

El equipo estándar (accesorios), las especificaciones y las fotografías pueden variar. Los accesorios pueden no estar incluidos desde origen con las herramientas aunque se indiquen en este catálogo.

Cuchilla para sierra de banda

Espesor: 0,5mm

Para modelo: LB1200F



Ancho (mm)	Dientes por In	Aplicación	Parte No.
16	4	Madera / para corte cruzado	B-16667
13	4	Madera / para universal	B-16673
6	6	Madera / para corte curvo	B-16689
16	14	Metal no ferroso	B-16695



Cuchilla para sierra de banda

Ancho: 13mm Grosor: 0.5mm Longitud: 1,140mm

Para modelo: BPP180, 2106, 2107F

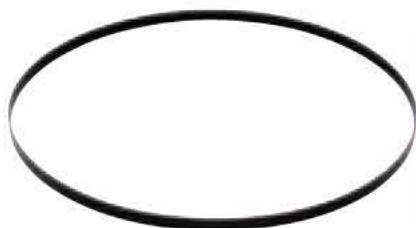

Diente de honda

Tipo	Espesor de la pieza de trabajo	Dientes por In	Aplicación	Parte No.
Acero al carbón (juego de 3 piezas)	4 mm- 5 mm	18	Plásticos y metal no ferroso, acero dulce, acero fundido, hierro fundido	792559-8
Acero al carbón	32" X 1/2"	14	metal P/ PB181B	B-40543
Acero al carbón	32" X 1/2"	18	metal P/ PB181B	B-40559
Acero al carbón	32" X 1/2"	24	metal P/ PB181B	B-40565

Abrazadera de segueta

(Para uso de hojas de vastago de 6,35 mm)



Modelo No.	No. Parte
4300BA, 4300BV	132276-260

Protector

(cubierta transparente delante de la hoja)



Modelo No.	No. Parte
4331D, 4333D, 4334D	415887-1

Placas de acrílico anti-astillas

(para cortes más limpios)

Evita el astillamiento de la madera al cortar con caladora



(Paquete de 5 piezas)

Modelo No.	No. Parte.
4326, 4327, 4328	192733-2
4323	416477-3

ACCESORIOS

Guía paralela

Guía de inclinación

A: regla de guía y set de reglas circulares



B: Regla de guía

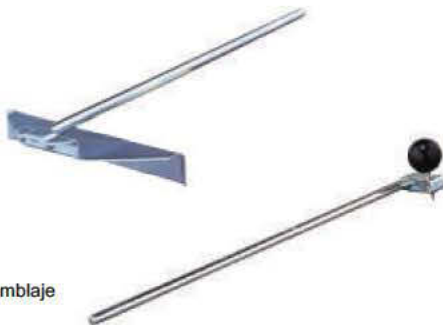

Guía circular de ensamble

Modelo No.	Tipo	No. Parte
4300BA, 4300BV	-	164113-2
4326/M, 4327/M, 4328, 4329, JV0600	A	192732-4
4300BA, 4300BV, 4301SB	B	123030-5

Base para caladora



Modelo No.	No. Parte
4331D, 4333D, 4334D	413068-1
4304	344443-9

Conector para aspiradora

Cabeza para aspiradora



Modelo No.	No. Parte
4331D, 4333D, 4334D	192547-9

Seguetas para caladora de banco

(Para madera)



Espesor	Corte	Diente	Triscado	Acabado	Longitud total	Longitud corte	No. Parte
1"	Recto	15 x in.	Exterior	Regular	130mm	80mm	351011-000

Cuchillas para cizallas

	Aplicación	Para	Empaque Pieza	No. Parte
	Cabezal de corte	JS1300	1	125112-9
	Cabezal de corte	JS8000	1	125354-5
	Cuchilla central	BJS130	1	725094-1
	Cuchilla central	BJS161, JS1660, JS1601	1	792534-4
	Cuchilla central	JS1300	1	792744-3
	Cuchilla central	JS1670	1	792537-8
	Cuchilla central	JS8000	1	725129-8
	Cuchilla derecha	BJS130	1	725092-5
	Cuchilla derecha	JS1300	1	792742-7
	Cuchilla izquierda	BJS130	1	725093-3
	Cuchilla izquierda	JS1300	1	792743-5
	Cuchilla lateral	JS8000	1	725130-3
	Juego de cuchillas	JS1600, JS1602		191383-0
	Juego de cuchillas	JS1670	Juego 2 piezas	792536-0
	Juego de cuchillas	JS3200, JS3201	Juego 2 piezas	792287-5
	Juego de cuchillas	BJS161, JS1660, JS1601	Juego 2 piezas	792533-6

Punzones para roedoras

	Tipo	Para	Empaque Pieza	No. Parte
	Punzón	JN1600, JN1602	1	792265-5
	Punzón	JN3200, JN3201	1	792728-1
	Punzón de repuesto	JN1601	1	A-83951

Matriz para roedoras

	Tipo	Para	Empaque Pieza	No. Parte
	Matriz	JN3200, JN3201	1	792292-2
	Soporte de punzón	JN1601	1	A-15051

El equipo estándar (accesorios), las especificaciones y las fotografías pueden variar. Los accesorios pueden no estar incluidos desde origen con las herramientas aunque se indiquen en este catálogo.

Calibrador de cuchillas



Tipo	Para	Empaque Pieza	No. Parte
Calibrador de cuchillas	JS1650	1	762013-6
Calibrador de cuchillas	JS3200	1	762007-1

Cuchillas par cortadora de varilla



Descripción	Aplicación	Empaque Pieza	No. Parte
Cuchillas para cortador de varilla CT	Repuestos para cortadora de varilla SC161	Juego de cuchillas y tornillos de sujeción	SC00000111
Cuchillas para cortador de varilla HSS	Repuestos para cortadora de varilla SC161	Juego de cuchillas y tornillos de sujeción	SC00000160
Cuchillas para cortador de varilla	Repuestos para cortadora de varilla DSC250	Juego de cuchillas y tornillos de sujeción	SC09002890

Accesorios para cepillos

Cuchillas



Tipo	Usar en	Medida	Características	Empaque Pieza	No. Parte
Carburo de tungsteno	1100,1100NH, N1900B,1902	82 mm	Juego dos cuchillas de repuesto	1	D-07945
Carburo de tungsteno	1100,1100NH, N1900B,1902	82 mm	Juego de dos cuchillas con cabeza reemplazable	1	D-07951
Carburo de tungsteno	1100,1100NH, N1900B,1902	82 mm	Juego de dos cuchillas tipo pulir, afilable.	1	D-07967
Acero rápido	1100,1100NH, N1900B,1902	82 mm	Juego de dos cuchillas afilables.	1	D-16346
Acero rápido	N1900B	82 mm	Juego de dos cuchillas afilables.	1	A-07406
Acero rápido	1050DWAE	50 mm.	Juego de dos cuchillas afilables.	1	A-85400
Acero rápido	1600	3-1/8" (80 mm)	Juego de dos cuchillas afilables.	1	A-07397
Acero rápido	1912B	4-3/8"	Juego de dos cuchillas afilables.	1	793008-8
Acero rápido	1804N	136mm	Juego de dos cuchillas afilables.	1	793011-9
Acero rápido	1805N	6-1/8"	Juego de dos cuchillas afilables.	1	793013-5
Carburo de tungsteno	1805N	6-1/8"	Juego de dos cuchillas afilables.	1	793015-1
Carburo de tungsteno	1806B	170mm.	Juego de dos cuchillas afilables.	1	793186-4
Carburo de tungsteno	1806B	170mm.	Juego de dos cuchillas afilables.	1	D-63666
Carburo de tungsteno	2012NB	12" (305mm)	Juego de dos cuchillas reemplazables.	1	793346-8
Carburo de tungsteno	KP312S	312mm.	Juego de dos cuchillas reemplazables.	1	B-02864
Carburo de tungsteno	2030S	321mm.	Juego de dos cuchillas reemplazables.	1	B-02870

Porta cuchillas



Usar en	Medida	Características	Empaque Piezas	No. Parte
1912B	4-3/8"	Sujeción de cuchillas de repuesto	1	123062-2
1805B	6-1/8"	Sujeción de cuchillas de repuesto	1	123009-6

Soporte para afilado



Usar en	Medida	Características	Empaque Piezas	No. Parte
1912B	4-3/8"	Soporte para afilar cuchillas para cepillo	1	123055-9
N1900B	82mm	Soporte para afilar cuchillas para cepillo	1	123004-6

Calibrador de cuchillas



Usar en	Medida	Características	Empaque Piezas	No. Parte
N1900B		Calibrador de cuchillas	1	123010-1

Guías de cepillo



Usar en	Tipo	Características	Empaque Piezas	No. Parte
1805N	Guías paralela	Guías para cepillo	1	191454-3
1902	Guías paralela	Guías para cepillo	1	191455-1
1900B	Guías de nivel	Guías para cepillo	1	123060-6
1805B	Guías de nivel	Guías para cepillo	1	123053-3

Piedra para afilado



Usar en	Medida	Características	Empaque Piezas	No. Parte
Cuchillas de acero de alta velocidad	180x70x 20mm	Piedra para afilado de cuchillas para cepillo grano 1200	1	794060-9

Llaves para herramientas

	Tipo	Usar en	Medidas	Para modelo	No. Parte
	Llave hexagonal p/Bujía	Ajuste de tornillos hexagonales	3/4" X 5/8"	Desbrozadora de mochila EBH340R	060000026N
	Llave allen	Ajuste de tornillos hexagonales	3mm	JN3200,JS1600, JS1660,JS1670,4331D, 4333D,4334D,4300BA, 4300BV,4326/M,4327/M,4328, 4329,JV6000	783201-2
	Llave allen	Ajuste de tornillos hexagonales	4mm	Desbrozadora de mochila EBH340R	060040000N
	Llave allen	Ajuste de tornillos hexagonales	4mm.	JS3200,4350T/CT/FCT, 4351T/CT/FCT,BJV140, BJV180,1806B,N1923B, 1911B	783202-0
	Llave allen	Ajuste de tornillos hexagonales	5mm.	Desbrozadora RBC411	0717059990
	Llave allen	Ajuste de tornillos hexagonales	5mm.	2711,2708W,5740NB, 5044KB, 4101RH	783203-8
	Llave allen	Ajuste de tornillos hexagonales	6mm.	HM1211	783204-6
	Llave allen	Ajuste de tornillos hexagonales	8mm.	HM1500	783207-0
	Llave allen	Ajuste de tornillos hexagonales	10mm.	HM1211B	783210-1
	Llave Hex.	Ajuste de tornillos hexagonales	4mm.	Desbrozadora RBC413U, RBC414U	783223-2
	Llave hexagonal	Ajuste de tornillos hexagonales	23mm.	RD1100,RD1101, RF1100,RF1101	781031-5
	Llave hexagonal	Ajuste de tornillos hexagonales	13mm.	5057KB,5277B, 5077B,5177B	782016-4
	Llave hexagonal	Ajuste de tornillos hexagonales	13-22mm.	2702,2703	782021-1
	Llave de contratuerca con pernos	Bridas de apriete	20mm.	3901,9500N, 9523NBH,LXJP02, PC1100, PJ7000	782401-1
	Llave de dado hexagonal	Apriete de tornillos	13mm.	Desbrozadora de mochila EBH340R	060000015N
	Llave de dado hexagonal	Apriete de tornillos	13mm.	EM4250	6249000000
	Llave de dado hexagonal	Apriete de tornillos	13mm.	EF1550RH	6909093000
	Llave de dado hexagonal	Apriete de tornillos	22mm.	MT410	781041-2
	Llave de dado hexagonal	Apriete de tornillos	9mm.	2012, 2012NB	782203-5
	Llave de dado hexagonal	Apriete de tornillos	6mm.	4200H, 5005BA	782209-3
	Llave de dado hexagonal	Apriete de tornillos	17mm.	2414NB,4100C, 4112H,BBC231U, BC231UD,BC300LD, HML01,LC1210, LC1230,MLC140, MLC141,MT240	782210-8

	Tipo	Usar en	Medidas	Para modelo	No. Parte
	Llave de dado hexagonal	Para instalación de discos de sierra	13mm.	Todas las sierras angulares y compuestas Makita	782212-4
	Llave española	Apriete de tornillos	8 x 10mm.	Desbrozadora de mochila EBH340R	302040600N
	Llave española	Apriete de tornillos	10mm.	3700D,906H,GE0600	781003-0
	Llave española	Apriete de tornillos	13mm.	3621,MRP090,RP0900, UT1301,UT1305, UT2204	781006-4
	Llave española	Apriete de tornillos	16mm (5/8")	Rebajadora 3706, pulidora 9217SPC	781008-0
	Llave española	Apriete de tornillos	10mm	2708W,4200H,5077B, 5201NA,5402A,4101RH	781011-1
	Llave española	Apriete de tornillos	19mm	2702, 2703	781027-6
	Llave española	Apriete de tornillos	24mm	Router 3612B,3612C	781030-7
	Llave española	Apriete de tornillos	19mm	GD0800,GD0810C	781206-6
	Llave española	Apriete de tornillos	8mm	3612BR,3620	781213-9
	Llave inglesa	Tuerca de seguridad	50mm	JN3200	781019-5
	Llave inglesa	Tuerca de seguridad	32mm	JN1601	781028-4
	Llave para tuerca de seguridad	Tuerca de seguridad	35mm.	HR3851	782407-9
	Llave para pernos	Para bridas		Esmeriladoras angulares 7" y 9"	782412-6
	Llave para pernos	Para bridas		Esmeriladoras angulares 4-1/2"	782420-7
	Llave para pernos	Para bridas		Esmeriladoras angulares 4-1/2"	782424-9
	Llave torx	Para tornillos		DCS3501, DCS4301, DCS460, DCS520, DCS5000, DCS5030, DCS6400, DCS6401, DCS7300, DPC6400, DPC7311, DPC7331, EA4300F	940827000

El equipo estándar (accesorios), las especificaciones y las fotografías pueden variar. Los accesorios pueden no estar incluidos desde origen con las herramientas aunque se indiquen en este catálogo.

Cardas





Cardas para taladro

Carda tipo



0.3mm diámetro de alambre de acero prensado
Ideal para oxidación ligera y remoción de pintura para metal



Nylon grueso (#80)
Ideal para oxidación ligera y remoción de pintura para metal, madera y PVC



Nylon fino (#240)
Ideal para acabado en superficie de metal y PVC

Forma tipo



Tipo copa
Efectivo para superficies planas o rugosas



Tipo disco
Efectivo para trabajo en un punto



Tipo final
Efectivo para lugares estrechos o apretados



Tipo flap
Efectivo para tratamiento de madera

Gráfica de material

AA : Recomendado

A : Aceptable

Carda tipo			
	0.3mm diámetro de alambre de acero prensado	Nylon grueso (#80)	Nylon fino (#240)
Madera 		AA	AA
PVC 		AA	AA
Metal 	AA	AA	AA
Acabado (Superficie de metal)			 Carda de nylon fino (#240) después carda para cubierta Nylon (#80)

El equipo estándar (accesorios), las especificaciones y las fotografías pueden variar. Los accesorios pueden no estar incluidos desde origen con las herramientas aunque se indiquen en este catálogo.

Escobilla de nylon para taladro

Carda de nylon tipo copa



Tamaño	Grano	Diámetro	No. Parte
50mm(2")	(#80)	6mm (1/4")	D-45509
63mm(2-1/2")	(#80)	6mm (1/4")	D-45515
75mm(3")	(#80)	6mm (1/4")	D-45521
50mm(2")	(#240)	6mm (1/4")	D-45537
63mm(2-1/2")	(#240)	6mm (1/4")	D-45543
75mm(3")	(#240)	6mm (1/4")	D-45559

Disco de nylon para cepillado



Tamaño	Grano	Diámetro	No. Parte
38mm (1-1/2")	(#80)	6mm (1/4")	D-45565
50mm (2")	(#80)	6mm (1/4")	D-45571
63mm (2-1/2")	(#80)	6mm (1/4")	D-45587
75mm (3")	(#80)	6mm (1/4")	D-45593
100mm (4")	(#80)	6mm (1/4")	D-45602
38mm (1-1/2")	(#240)	6mm (1/4")	D-45618
50mm (2")	(#240)	6mm (1/4")	D-45624
63mm (2-1/2")	(#240)	6mm (1/4")	D-45630
75mm (3")	(#240)	6mm (1/4")	D-45646
100mm (4")	(#240)	6mm (1/4")	D-45652

Escobilla de nylon para acabado



Tamaño	Grano	Diámetro	No. Parte
12mm (1/2")	(#80)	6mm (1/4")	D-45668
19mm (3/4")	(#80)	6mm (1/4")	D-45674
25mm (1")	(#80)	6mm (1/4")	D-45680
30mm (1-1/4")	(#80)	6mm (1/4")	D-45696
12mm (1/2")	(#240)	6mm (1/4")	D-45705
19mm (3/4")	(#240)	6mm (1/4")	D-45711
25mm (1")	(#240)	6mm (1/4")	D-45727
30mm (1-1/4")	(#240)	6mm (1/4")	D-45733

Cepillo de nylon tipo flap



Tamaño	Grano	Diámetro	No. Parte
100mm(4")	(#80)	6mm (1/4")	D-45749
100mm(4")	(#240)	6mm (1/4")	D-45755

Carda copa de alambre para taladro

Carda de alambre tipo copa



Tamaño	Diámetro	No. Parte
38mm (1-1/2")	6mm (1/4")	D-39908
50mm (2")	6mm (1/4")	D-39914
63mm (2-1/2")	6mm (1/4")	D-39920
75mm (3")	6mm (1/4")	D-39936
80mm (3-1/8")	6mm (1/4")	D-39942

Carda circular de alambre para taladro



Tamaño	Diámetro	No. Parte
38mm (1-1/2")	6mm (1/4")	D-39958
50mm (2")	6mm (1/4")	D-39964
63mm (2-1/2")	6mm (1/4")	D-39970
75mm (3")	6mm (1/4")	D-39986
100mm (4")	6mm (1/4")	D-39992

Carda tipo brocha para taladro



Tamaño	Diámetro	No. Parte
12mm (1/2")	6mm (1/4")	D-40004
19mm (3/4")	6mm (1/4")	D-40010
25mm (1")	6mm (1/4")	D-40026
30mm (1-1/4")	6mm (1/4")	D-40032

ACCESORIOS

Carda copa de alambre ondulado

Empaque plástico



Para modelo	Tamaño	Cuerda	No. Parte
B	2-1/2"	M14	D-55099
B	3"	M14	D-55108
C	4"	M14	D-55114

Carda copa de alambre ondulado latonado

Empaque plástico



Para modelo	Tamaño	Cuerda	No. Parte
B	2-1/2"	M14	D-55348*
B	3"	M14	D-55354
C	3-1/2"	M14	D-55360*
C	4"	M14	D-55376*

Carda copa de alambre trenzado

Empaque plástico
*Cónica



Para modelo	Tamaño	Cuerda	No. Parte
B	2-1/2"	M14	D-55164*
B	3"	M14	D-55170
B	2-1/2"	M14	D-55217
C	4"	M14	D-55223

Carda circular de alambre trenzado



Para modelo	Tamaño	Cuerda	No. Parte
C	6"	M14	D-45761
C	7"	M14	D-45777
C	4"	M14	D-55245
C	4-1/2"	M14	D-55251
C	5"	M14	D-55267
C	6"	M14	D-55273
C	7"	M14	D-55289

Carda circular cóncava alambre ondulado

Empaque plástico



Para modelo	Tamaño	Cuerda	No. Parte
C	4"	M14	D-55382
C	4-1/2"	M14	D-55398

Carda circular cónica Alambre trenzado



Para modelo	Tamaño	Cuerda	No. Parte
C	4"	M14	D-55407
C	4-1/2"	M14	D-55413

El equipo estándar (accesorios), las especificaciones y las fotografías pueden variar. Los accesorios pueden no estar incluidos desde origen con las herramientas aunque se indiquen en este catálogo.

Carda copa de alambre ondulado

Empaque de plástico

Carda de alambre ondulado tipo copa



Para modelo	Tamaño	Cuerda	No. Parte
B	2-1/2"	5/8"	D-55120
C	3"	5/8"	D-55136
C	4"	5/8"	D-55310

Carda copa de alambre ondulado latonado

Empaque de plástico



Para modelo	Tamaño	Cuerda	No. Parte
B	2-1/2"	5/8"	D-55429
B	3"	5/8"	D-55435
C	3-1/2"	5/8"	D-55441
C	4"	5/8"	D-55457

Carda copa de alambre trenzado

Empaque de plástico



Para modelo	Tamaño	Cuerda	No. Parte
B	2-1/2"	5/8"	D-55186
B	3"	5/8"	D-55192
C	2-1/2"	5/8"	D-55239
C	4"	5/8"	D-55326
B	4"	5/8"	D-55332

Carda circular cóncava

Alambre ondulado

Para modelo	Tamaño	Cuerda	No. Parte
C	4"	5/8"	D-55463
C	4-1/2"	5/8"	D-55479

Carda circular cóncava

Alambre ondulado

Para modelo	Tamaño	Cuerda	No. Parte
C	4"	5/8"	D-55485
B	4-1/2"	5/8"	D-55491

Carda circular de alambre trenzado

Para modelo	Tamaño	Cuerda	No. Parte
C	6"	5/8"	D-55295
C	7"	5/8"	D-55304

Carda copa de alambre ondulado

Para modelos:

- A: 100mm disco / esmeriladora
- B: 125, 150mm esmeriladora
- C: 180, 230mm esmeriladora
- D: 230mm esmeriladora



(Ideal para remover oxido en superficies planas y bordes)

Para modelo	Tamaño	Cuerda	No. Parte
A	2-1/2"	5/8"-11	D-26515
A	3"	5/8"-11	D-26521
C	4"	5/8"-11	D-31697

ACCESORIOS

Cardas

Carda copa de alambre trenzado

0.5mm alambre de acero trenzado 2
(Ideal para trabajo pesado, alambre de acero trenzado anudado doble, más fuerte)



Para modelo	Tamaño	Cuerda	No. Parte
A	2-1/2"	5/8"-11	D-26537
A	3"	5/8"-11	D-26543
A	2-1/2"	5/8"-11	D-26559
C	4"	5/8"-11	D-31706
C	4"	5/8"-11	D-31712

Carda copa de alambre ondulado latonado



(Ideal para remover oxido en superficies planas y bordes)

Para modelo	Tamaño	Cuerda	No. Parte
B	2-1/2"	5/8"-11	D-39752
B	3"	5/8"-11	D-39774
C	3-1/2"	5/8"-11	D-39796
C	4"	5/8"-11	D-39811

Carda circular cóncava de alambre ondulado

Mejor para limpiar por todos lados



Para modelo	Tamaño	Cuerda	No. Parte
B, C	4"	5/8"-11	D-39833
B, C	4-1/2"	5/8"-11	D-39855

Carda circular de alambre trenzado

0.5mm alambre de acero trenzado
Efectivo para orillas y esquinas



Para modelo	Tamaño	Cuerda	No. Parte
B, C	4"	5/8"-11	D-39877
B, C	4-1/2"	5/8"-11	D-39899

Carda circular cónica de alambre ondulado

0.5mm alambre de acero



(Para esmeriladoras angulares de todas las marcas 4-1/2", 7", 9")

Tipo	Diámetro	Eje	No. Parte
Copa	2-1/2"	Multirosca (M14 - 5/8")	T-01993
Copa	4"	Multirosca (M14 - 5/8")	T-02004
Copa	5"	Multirosca (M14 - 5/8")	T-02010

Carda circular multirosca

Tipo	Diámetro	Eje	No. Parte
Cóncava	3-1/2"	Multirosca (M14 - 5/8")	T-02026

Carda de copa de alambre trenzado multirosca



(Para esmeriladoras angulares de todas las marcas 4-1/2", 7", 9")

Tipo	Diámetro	Eje	No. Parte
Copa	3"	Multirosca (M14-5/8")	P-04488
Copa	3-1/2"	Multirosca (M14-5/8")	P-04472

Carda circular multirosca Trenzada

Tipo	Diámetro	Eje	No. Parte
Circular	4"	Multirosca (M14-5/8")	P-04494

Cepillo- Tipo rodillo (USA)

Para modelo 9741

Aplicación	Grano	No. Parte
Para lijar	#40	794380-1
Para acabado en metal		794382-7
Para lijar	#80	794384-3
Para lijar (medio)	#100	794379-6
Para lijar (fino)	#240	794383-5



El equipo estándar (accesorios), las especificaciones y las fotografías pueden variar.
Los accesorios pueden no estar incluidos desde origen con las herramientas aunque se indiquen en este catálogo.



Makita

ACCESORIOS



TIPO DE DISCOS

Esmerilando



Disco de desbaste con centro hundido

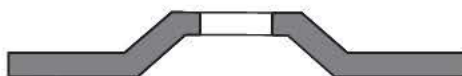

Diámetro 100mm~230mm
Grosor: 6.0mm



Disco de desbaste flexible

*Siempre utilice respaldo



Diámetro 100mm~230mm
Grosor: 3.0mm



Disco de corte para cortadora portátil



Diámetro 355mm~405mm
Grosor: 2.5mm~3.0mm



Cortando



Disco delgado de corte (plano)



Diámetro 100mm~230mm
Grosor: 0.8mm~2.0mm



Disco delgado de corte con centro hundido



Diámetro 100mm~230mm
Grosor: 0.8mm~2.0mm



Disco de corte (plano)



Diámetro 100mm~230mm
Grosor: 2.5mm~3.0mm



Disco de corte con centro hundido



Diámetro 100mm~230mm
Grosor: 3.0mm



El equipo estándar (accesorios), las especificaciones y las fotografías pueden variar.
Los accesorios pueden no estar incluidos desde origen con las herramientas aunque se indiquen en este catálogo.

DISCO ABRASIVO

Cómo leer las especificaciones:

Grupo de alúmina de óxido



aluminio fundido café: A



Carburo de silicio: C



Óxido blanco de aluminio: WA



Alúmina de zirconio: Z



Tamaño del grano



Tipo Bond



Resina = Resinoide (BF)

Componente principal es la resina de fenol Mecánicamente fuerte, pero débil contra la humedad y el calor"

Dureza del disco



Cerca de A, disco de desbaste suave
Cerca de Z, disco de desbaste fuerte
Disco de desbaste ▶ Pieza dura de trabajo
Disco de desbaste ▶ Pieza de trabajo suave

Muy suave	Suave	Medio	Duro	Muy fuerte
A - G	H - K	L - O	P - S	T - Z

Parte No. B-12217

Medida 115 x 1 x 22.23mm
4-1/2" x 3/64" x 7/8"

Velocidad máxima de operación max. 80m/s (4800 m/min)
max. 13300min⁻¹ (13300rpm)

Estándar EN 12413

Pictogramas de uso seguro

Aplicación INOX

Código color A60T-BF

Especificaciones

Validez

Legenda:
Azul: Metal
Oro: INOX
Verde: Mampostería
Plata: Aluminio

Makita

ACCESORIOS

DISCOS ABRASIVOS 2 EN 1



Características

1. Desbaste y corte con un solo disco.
 2. Ahorro de tiempo y costo gracias a su eficiencia de trabajo.
 3. Recomendable para profesional DIY.
 4. Hecho de acuerdo con la guía oSa.
- Cubiertas: EN 12413.

Aplicación y ángulo

Desbaste



Desbaste limpio

Corte



Corte fino, fácil y exacto



Desbaste



Corte



Eliminar rebabas

El equipo estándar (accesorios), las especificaciones y las fotografías pueden variar.
Los accesorios pueden no estar incluidos desde origen con las herramientas aunque se indiquen en este catálogo.



DISCOS DE DESBASTE FLEXIBLE

Características

1. Menos ruido.
2. Baja vibración.
3. Disco abrasivo flexible casi sin tocar, provee un excelente trabajo.
4. Amplia gama de aplicaciones.



Esmeriladoras



Pulido



Rectificado

Dirección para colocación y uso

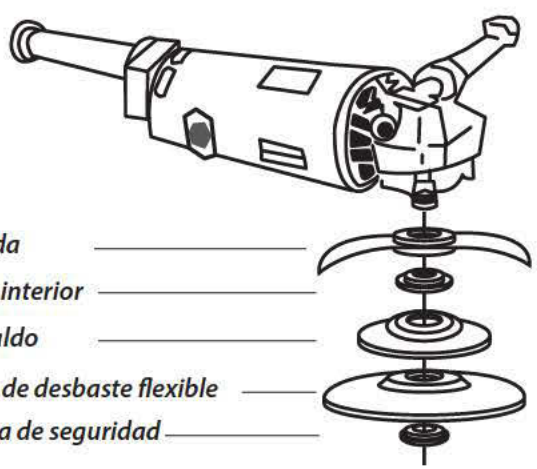

Operación angular

La operación angular puede ser mantenida de 15 - 30°

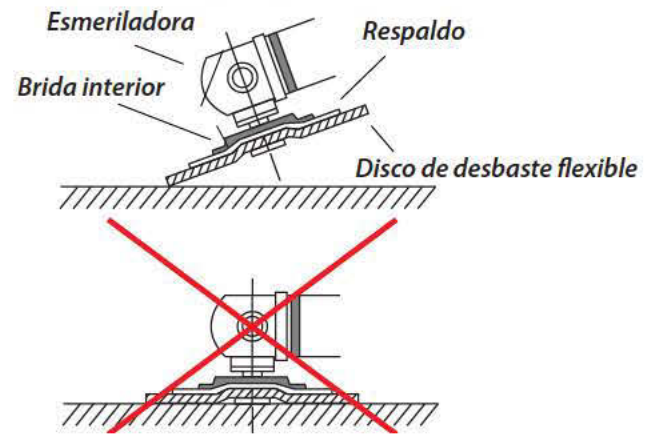

Makita

ACCESORIOS

DISCO ABRASIVO 2 EN 1 B-52071



¡Ahora es posible cortar y desbastar con un solo disco!

Ideal para miniesmeril inalámbrico

CORTE



DESBASTE



Conveniente en trabajos de Altura



Para trabajos de **construcción, industria metal mecánica y plomería**

Reduce la carga al corte 10% más velóz por la alta calidad de grano SA (Aluminio simple)

No. parte:

B-52071

Material

Metal / Inox

Grano

46

Tamaño

4 -1/2"

Empaque piezas

1

El equipo estándar (accesorios), las especificaciones y las fotografías pueden variar. Los accesorios pueden no estar incluidos desde origen con las herramientas aunque se indiquen en este catálogo.

Discos flexibles para corte y desbaste



Discos para desbaste de metal / inox / aluminio



Material	Eje	Diámetro	Grano	Empaque Piezas	No. Parte
Acero y metales ferrosos	7/8"	4 1/2"	36	1	B-18275
Acero y metales ferrosos	7/8"	4 1/2"	60	1	B-18297
Acero y metales ferrosos	7/8"	4 1/2"	80	1	B-18306
Acero y metales ferrosos	7/8"	7"	36	1	B-18356
Acero y metales ferrosos	7/8"	7"	60	1	A-88490
Acero inoxidable	7/8"	4 1/2"	36	1	B-18502
Acero inoxidable	7/8"	4 1/2"	60	1	B-18524
Acero inoxidable	7/8"	4 1/2"	80	1	B-18530
Acero inoxidable	7/8"	7"	36	1	B-18580
Acero inoxidable	7/8"	7"	60	1	B-18605
Respaldo de plástico (Complemento indispensable)	Respaldo de plástico	4 1/2"	s/n	1	B-20482
Respaldo de plástico (Complemento indispensable)	Respaldo de plástico	7"	s/n	1	B-20498

Material	Eje	Diámetro	Espesor	Empaque Piezas	No. Parte
Metal uso general	7/8"	4"	1/4"	1	D-56471
Metal uso general	7/8"	4"	1/4"	1	D-56487
Metal uso general	7/8"	7"	1/4"	1	D-56493
Metal uso general	5/8"	4"	3/16"	1	741402-B
Metal uso general	7/8"	4-1/2"	1/4"	1	B-44264
Metal uso general	7/8"	7"	1/4"	1	B-44286
Metal uso general	7/8"	9"	1/4"	1	B-44301
Acero inoxidable	7/8"	4-1/2"	1/4"	1	B-44111
Acero inoxidable	7/8"	5"	1/4"	1	B-44161
Acero inoxidable	7/8"	7"	1/4"	1	B-44199
Acero inoxidable	7/8"	9"	1/4"	1	B-44236
Aluminio	7/8"	4"	1/4"	1	B-44052
Aluminio	7/8"	4-1/2"	1/4"	1	B-44105
Aluminio	7/8"	5"	1/4"	1	B-44155
Aluminio	7/8"	7"	1/4"	1	B-44183
Aluminio	7/8"	9"	1/4"	1	B-44220

Disco 2 en 1 (Desbaste y corte) Línea industrial

Para uso pesado en metales ferrosos y acero inoxidable



Discos para desbaste de metal / inox Alto rendimiento



*Especial para herramientas a batería

Material	Eje	Diámetro	Empaque Piezas	No. Parte
Acero y metales ferrosos	7/8"	4-1/2"	1	*B-50360
Acero y metales ferrosos	7/8"	4-1/2"	1	B-21238
Acero y metales ferrosos	7/8"	4-1/2"	1	B-44096
Acero y metales ferrosos	7/8"	7"	1	B-48686
Acero y metales ferrosos	7/8"	4-1/2"	1	B-52071

Material	Eje	Diámetro	Espesor	Empaque Piezas	No. Parte
Acero y metales ferrosos	5/8"	4"	1/4"	1	B-21157
Acero y metales ferrosos	7/8"	4-1/2"	1/4"	1	B-21163
Acero y metales ferrosos	7/8"	5"	1/4"	1	B-21179
Acero y metales ferrosos	7/8"	7"	1/4"	1	B-21185
Acero y fundición	7/8"	9"	1/4"	1	B-21191

ACCESORIOS

Discos de desbaste para industria pesada

Mejora la eficiencia del trabajo hasta un **130% más**

Grano: Oxido de aluminio



Grano: Zirconia
Larga vida

Espesor de 7.2mm

Material	Grano	Diámetro	Espesor	Empaque Piezas	No. Parte
Metal e inoxidable	A24S	4 1/2"	7.2mm	1	B-62290
Metal e inoxidable	AZ24N Zirconia	4 1/2"	7.2mm	1	B-62309
Metal e inoxidable	A24S	5"	7.2mm	1	B-62315
Metal e inoxidable	AZ24N Zirconia	5"	7.2mm	1	B-62321



El equipo estándar (accesorios), las especificaciones y las fotografías pueden variar. Los accesorios pueden no estar incluidos desde origen con las herramientas aunque se indiquen en este catálogo.

Discos abrasivos

Discos para desbaste de metal con adaptador



Material	Eje	Diámetro	Espesor	Empaque Piezas	No. Parte
Acero y metales ferrosos	5/8"	4 1/2"	1/4"	1	B-44270
Acero y metales ferrosos	5/8"	7"	1/4"	1	B-44292

Discos corte de aluminio



Material	Eje	Diámetro	Espesor	Empaque Piezas	No. Parte
Aluminio	5/8"	4"	1.1mm	1	B-50304
Aluminio	7/8"	4-1/2"	1.1mm	1	B-50310
Aluminio	7/8"	5-1/2"	1.1mm	1	B-50326
Aluminio	7/8"	6"	1.6mm	1	B-50332
Aluminio	7/8"	7"	1.6mm	1	B-50348
Aluminio	7/8"	9"	1.9mm	1	B-50354

Discos corte de metal 1.6 más rápidos



Material	Eje	Diámetro	Espesor	Empaque Piezas	No. Parte
Acero y metales	5/8"	4"	1.6mm	1	B-49529
Acero y metales	7/8"	4-1/2"	1.6mm	1	B-49535
Acero y metales	7/8"	5"	1.6mm	1	B-49541
Acero y metales	7/8"	7"	1.8mm	1	B-60470
Acero y metales	7/8"	9"	2.0mm	1	B-60486



DISCO ABRASIVO PARA CORTE 4-1/2" (115mm)

¡Más delgado, rápido, limpio y preciso!

0.8mm

Características



1. Menos rebaba de material



0.8mm



2.5mm



2. Menos polvo de material



0.8mm



2.5mm



ACCESORIOS

Discos para corte de metal 0.8mm



Planos

Material	Eje	Diámetro	Espesor	Empaque Piezas	No. Parte
Inox	5/8"	4"	0.8mm	1	B-48848
Inox	7/8"	4-1/2"	0.8mm	1	B-48670

Discos para corte de metal 0.8mm



Concavos

Material	Eje	Diámetro	Espesor	Empaque Piezas	No. Parte
Inox	7/8"	4-1/2"	0.8mm	1	B-49507
Inox	7/8"	5"	0.8mm	1	B-49513

Discos de corte

Línea profesional



*Especial para herramientas a batería

Material	Eje	Diámetro	Espesor	Empaque Piezas	No. Parte
Metal	5/8"	4"	3 mm.	1	B-44074
Metal	7/8"	4-1/2"	3 mm.	1	B-44127
Metal	7/8"	5"	1.6 mm.	1	B-35433
Metal	7/8"	7"	3 mm.	1	B-44208
Metal	7/8"	9"	3mm.	1	B-44242
Metal	7/8"	4-1/2"	3mm. Larga Vida	1	D-45456

Discos abrasivos

Discos de corte

Línea profesional



*Especial para herramientas a batería

Material	Eje	Diámetro	Espesor	Empaque Piezas	No. Parte
Metal	7/8"	7"	3mm. Larga Vida	1	D-45484
Metal	7/8"	4-1/2"	1.6 mm.	1	B-13817
Metal	7/8"	4-1/2"	1 mm.	1	724115-A
Metal	7/8"	7"	1.5 mm.	1	A-91447
Metal	7/8"	9"	1.9 mm.	1	A-91453
Acero inoxidable	7/8"	4-1/2"	4.0 mm.	1	B-49878*
Acero inoxidable	5/8"	4"	1 mm.	1	B-12441
Acero inoxidable	7/8"	4-1/2"	1 mm.	1	B-12457
Acero inoxidable	7/8"	4-1/2"	1.6 mm.	1	B-48692
Acero inoxidable	7/8"	5"	1 mm.	1	B-12479
Acero inoxidable	7/8"	7"	1.6 mm.	1	B-12500
Acero inoxidable	7/8"	9"	1.6 mm.	1	B-12516
Concreto	5/8"	4"	3 mm.	1	A-86745
Concreto	7/8"	4-1/2"	3 mm.	1	A-85254
Concreto	7/8"	7"	3 mm.	1	A-85276
Concreto	7/8"	9"	3 mm.	1	A-85282
Acero inoxidable	7/8"	4-1/2"	1 mm.	1	B-12457-10

Discos abrasivos línea clásica

Línea profesional



Material	Eje	Diámetro	Espesor	Empaque Piezas	No. Parte
Metal	1"	14"	3 mm	Caja 25 piezas	A-89872-25 Rojo
Metal	1"	14"	3 mm	Caja 25 piezas	B-30514-25 Gris
Metal	1"	14"	3 mm	Caja 25 piezas	B-54293-25 Gris
Metal	1"	14"	2.5 mm	Caja 25 piezas	B-57118-25 Gris
Metal	1"	14"	3 mm	Caja 25 piezas	B-14598-25 Doble malla
Metal	1"	16"	3 mm	Caja 25 piezas	A-87694-25 Doble malla

El equipo estándar (accesorios), las especificaciones y las fotografías pueden variar. Los accesorios pueden no estar incluidos desde origen con las herramientas aunque se indiquen en este catálogo.

Discos de corte

Línea estándar



Material	Eje	Diámetro	Espesor	Empaque Piezas	No. Parte
Metal	5/8"	100mm (4")	2.5 mm.	1	D-18297
Metal	7/8"	115mm (4-1/2")	2.5 mm.	1	D-18306
Metal	7/8"	125 mm (5")	2.5 mm.	1	D-18312
Metal	7/8"	180 mm (7")	2.5 mm.	1	D-18328
Metal	7/8"	230 mm (9")	2.5 mm.	1	D-18334
Acero inoxidable	5/8"	100mm (4")	1 mm.	1	D-18390
Acero inoxidable	7/8"	115mm (4-1/2")	1.2 mm.	1	D-18409
Acero inoxidable	7/8"	125 mm (5")	1.2 mm.	1	D-18415
Acero inoxidable	7/8"	180 mm (7")	2 mm.	1	D-18421
Acero inoxidable	7/8"	230 mm (9")	2 mm.	1	D-18437
Concreto	5/8"	100mm (4")	3 mm.	1	D-18340
Concreto	7/8"	115mm (4-1/2")	3 mm.	1	D-18356
Concreto	7/8"	125 mm (5")	3 mm.	1	D-18362
Concreto	7/8"	180 mm (7")	3 mm.	1	D-18378
Concreto	7/8"	230 mm (9")	3 mm.	1	D-18384
Concreto	7/8"	125 mm (5")	1.2 mm.	10	D-53447

Discos de desbaste con centro hundido (Tipo 27)

Línea estándar



Material	Eje	Diámetro	Espesor	Empaque Piezas	No. Parte
Metal	5/8"	100mm (4")	6 mm.	1	D-18188
Metal	7/8"	115mm (4-1/2")	6 mm.	1	D-18194
Metal	7/8"	125 mm (5")	2.5 mm.	1	D-18203
Metal	7/8"	180 mm (7")	6 mm.	1	D-18219
Metal	7/8"	230 mm (9")	6 mm.	1	D-18225
Concreto	5/8"	100mm (4")	6 mm.	1	D-18231
Concreto	7/8"	115mm (4-1/2")	6 mm.	1	D-18247
Concreto	7/8"	125 mm (5")	6 mm.	1	D-18253
Concreto	7/8"	180 mm (7")	6 mm.	1	D-18275
Concreto	7/8"	230 mm (9")	6 mm.	1	D-18281

Discos de corte Presentación en lata

Línea profesional

Material	Eje	Diámetro	Espesor	Empaque Piezas	No. Parte
Acero inoxidable	5/8"	4"	1 mm.	10	B-12441-10
Acero inoxidable	7/8"	5"	1 mm.	10	B-12479-10

Discos de corte Presentación en lata, Estuche aniversario 100 años



Línea estándar

Material	Eje	Diámetro	Espesor	Empaque Piezas	No. Parte
Acero inoxidable	7/8"	115mm 4-1/2"	1.2 mm	10	D-53431

Abrasivos para esmeriles

Ruedas abrasivas

*Rectificado y afilado de metales



**Esmerilado y afilado de acero al carbón y hierro forjado, entre otras aplicaciones

Usar en	Diámetro	Espesor	Eje	Grano	Empaque Piezas	No. Parte
GB600, GB601	150mm. (6")	25mm.(1")	12.7mm(1/2")	36G	1	*6005R (Derecha)
GB600, GB601	150mm. (6")	25mm.(1")	12.7mm(1/2")	60G	1	*6005L (Izquierda)
GB600, GB601	150mm. (6")	25mm.(1")	12.7mm(1/2")	A360Q (Mediano)	1	*6105R (Derecha)
GB600, GB601	150mm. (6")	25mm.(1")	12.7mm(1/2")	A060P (Fino)	1	*6105L (Izquierda)
GB800	205mm. (8")	25mm.(1")	15.88mm(5/8")	A60P (Mediano)	1	**8005L (Izquierda)
GB800	205mm. (8")	25mm.(1")		A36Q (Grueso)	1	**8005R (Derecha)

Ruedas abrasivas

Rectificado y afilado de metales



Usaren	Diámetro	Espesor	Eje	Grano	Empaque Piezas	No. Parte
9105	125mm. (5")	19mm(3/4")	12.7mm(1/2")	24G	1	*741015-5
9105	125mm. (5")	19mm(3/4")	12.7mm(1/2")	36G	1	*741016-3

Ruedas abrasivas

Para esmeril de banco

Material	Diámetro	Espesor	Eje	Grano	Empaque Piezas	No. Parte
metal	150mm	16mm(5/8")	12.7mm(1/2")	A36M	1	B-51904
metal	150mm	16mm(5/8")	12.7mm(1/2")	A60M	1	B-51910
no ferrosos	150mm	16mm(5/8")	12.7mm(1/2")	GC120H	1	B-51932
metal	205mm	19mm(3/4")	15.88mm	A36P	1	B-51948
metal	205mm	19mm(3/4")	15.88mm	A60P	1	B-51954
no ferrosos	205mm	19mm(3/4")	15.88mm	GC120H	1	B-51976

Piedra para afilar

Usar en	Parte No.
3501N	794063-3
906/H	794217-2
9803	A-24642



Puntas montadas para rectificador



Usar en	Forma	Espesor	Zanco	Empaque Piezas	No. Parte
906.GD0800C, GD0810C, GD0600, BGD800, BGD801	Cilíndrica	19mm (3/4")	1/4"	1"	741617-7
906.GD0800C, GD0810C, GD0600, BGD800, BGD801	Cónica	19mm (3/4")	1/4"	1"	741616-9

Limas rotativas para metal

Línea estándar

10 veces más velocidad de corte y hasta 200 veces más durabilidad que las limas montadas



Lima standard

Remueve y desbasta con gran eficiencia

Material	Zanco	Tipo	Forma	Empaque Piezas	No. Parte
Metal	1/4"	Estándar	Cilíndrica	1	B-52962
Metal	1/4"	Estándar	Redonda	1	B-52990
Metal	1/4"	Estándar	Árbol	1	B-53023
Metal	1/4"	Estándar	Cónica	1	B-53051
Metal	1/4"	Estándar	Cónica	1	B-53089

Limas rotativas para Inox

Línea estándar



Lima Diamante

Reduce la vibración y un manejo suave evitando fatiga al operador

Material	Zanco	Tipo	Forma	Empaque Piezas	No. Parte
Inox	1/4"	Diamante	Cilíndrica	1	B-52978
Inox	1/4"	Diamante	Redonda	1	B-53001
Inox	1/4"	Diamante	Árbol	1	B-53039
Inox	1/4"	Diamante	Cónica	1	B-53067
Inox	1/4"	Diamante	Cónica	1	B-53095

Limas rotativas para aluminio

Línea estándar



Lima No ferroso

Previene atascos en el uso evitando dañar el material

Material	Zanco	Tipo	Forma	Empaque Piezas	No. Parte
Aluminio	1/4"	No ferrosos	Cilíndrica	1	B-52984
Aluminio	1/4"	No ferrosos	Redonda	1	B-53017
Aluminio	1/4"	No ferrosos	Árbol	1	B-53045
Aluminio	1/4"	No ferrosos	Cónica	1	B-53073
Aluminio	1/4"	No ferrosos	Cónica	1	B-53104

Productos de lija y fibra



118° borde de cincel



135° Punta dividida



HSS-R



HSS-G



Alta velocidad cobalto 5%



M-force



Estaño alta velocidad



Para martillos SDS-plus



Punta de carburo de tungsteno



Utilice refrigerante



No perfora con impacto



PAPEL LIJA

Estructura

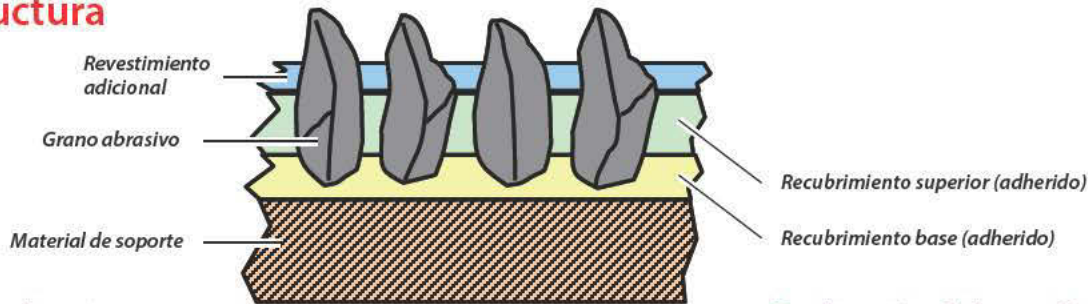

Grano abrasivo

Tipo de material	Óxido de aluminio	Carburo de silicio	Zirconia alumina
Imagen			
Código de grano	A&WA	C	Z
Aplicación	Madera, metal, etc.	Piedra, hierro fundido, vidrio, etc.	Aceros, tableros de fibra etc.

Explicación del tamaño de grano

	Grueso	Medio	Fino	Muy fino
Tamaño de grano	- 80	80 - 120	120 - 400	400 -
Imagen				

Disco flap



Gráfica de material

AA : Recomendado A: Aceptable

Descripción del material del grano	A Alúmina de óxido	Z Alúmina de zirconio	C Carburo de silicón	Ca óxido de aluminio cerámico
Descripción de la etiqueta de color				
Madera	A			
Plástico	A			
Metal	AA	AA		
No ferroso	A	A		AA
Inoxidable		AA		AA
Mampostería			AA	AA

Grano tipo / medida del grano



Tipo de apoyo



El equipo estándar (accesorios), las especificaciones y las fotografías pueden variar. Los accesorios pueden no estar incluidos desde origen con las herramientas aunque se indiquen en este catálogo.

Hoja de lija completa (23x28cm)

Para madera



Usar en	Grano	Empaque Piezas	No. Parte
Madera	40	Paq. 50 pzs.	D-51683
Madera	60	Paq. 50 pzs.	D-51699
Madera	80	Paq. 50 pzs.	D-51708
Madera	100	Paq. 50 pzs.	D-51714
Madera	120	Paq. 50 pzs.	D-51720
Madera	150	Paq. 50 pzs.	D-51736
Madera	180	Paq. 50 pzs.	D-51742
Madera	240	Paq. 50 pzs.	D-51758
Madera	320	Paq. 50 pzs.	D-56873
Madera	400	Paq. 50 pzs.	D-56889

Hoja de lija completa (23x28cm)

Para piedra



Usar en	Grano	Empaque Piezas	No. Parte
Piedra	60	Paq. 50 pzs.	D-56530
Piedra	80	Paq. 50 pzs.	D-56546
Piedra	100	Paq. 50 pzs.	D-56552
Piedra	120	Paq. 50 pzs.	D-56568
Piedra	150	Paq. 50 pzs.	D-56574
Piedra	180	Paq. 50 pzs.	D-56580
Piedra	240	Paq. 50 pzs.	D-56596

Hoja de lija completa (23x28cm)

Para metal



Usar en	Grano	Empaque Piezas	No. Parte
Metal	36	Paq. 50 pzs.	D-56677
Metal	40	Paq. 50 pzs.	D-56683
Metal	60	Paq. 50 pzs.	D-56699
Metal	80	Paq. 50 pzs.	D-56708
Metal	100	Paq. 50 pzs.	D-56714
Metal	120	Paq. 50 pzs.	D-56720
Metal	150	Paq. 50 pzs.	D-56736
Metal	180	Paq. 50 pzs.	D-56742
Metal	240	Paq. 50 pzs.	D-56758

Hoja de lija completa (23x28cm) de agua

Para metal



Usar en	Grano	Empaque Piezas	No. Parte
Metal	60	Paq. 50 pzs.	D-58936
Metal	80	Paq. 50 pzs.	D-58942
Metal	100	Paq. 50 pzs.	D-58958
Metal	120	Paq. 50 pzs.	D-58964
Metal	150	Paq. 50 pzs.	D-58970
Metal	180	Paq. 50 pzs.	D-58986
Metal	220	Paq. 50 pzs.	D-58992
Metal	240	Paq. 50 pzs.	D-59003
Metal	320	Paq. 50 pzs.	D-59019
Metal	400	Paq. 50 pzs.	D-59025
Metal	400	Paq. 50 pzs.	D-59031
Metal	400	Paq. 50 pzs.	D-59047
Metal	400	Paq. 50 pzs.	D-59053
Metal	1200	Paq. 50 pzs.	D-56851
Metal	1200	Paq. 50 pzs.	D-59069
Metal	1200	Paq. 50 pzs.	D-59075

Hoja de lija completa (23x28cm)

Para pintura

Usar en	Grano	Empaque Piezas	No. Parte
Pintura	80	Paq. 100 pzs.	D-60698
Pintura	100	Paq. 100 pzs.	D-60707
Pintura	120	Paq. 100 pzs.	D-60713
Pintura	150	Paq. 100 pzs.	D-60729
Pintura	180	Paq. 100 pzs.	D-60735
Pintura	220	Paq. 100 pzs.	D-60741
Pintura	240	Paq. 100 pzs.	D-60757
Pintura	280	Paq. 100 pzs.	D-60763
Pintura	320	Paq. 100 pzs.	D-60779
Pintura	360	Paq. 100 pzs.	D-60785
Pintura	400	Paq. 100 pzs.	D-60791
Pintura	500	Paq. 100 pzs.	D-60800
Pintura	600	Paq. 100 pzs.	D-60816
Pintura	800	Paq. 100 pzs.	D-60822

Rollo de lija



Diámetro	Grano	Empaque Piezas	No. Parte
120mm x 5m	60	1	P-38118
120mm x 5m	80	1	P-38124
120mm x 5m	120	1	P-38146

ACCESORIOS

Productos de lija y fibra

Lija 1/4" de hoja para madera



Usar en	Grano	Empaque Piezas	No. Parte
Madera	80	5 pzs.	A-920315
Madera	120	5 pzs.	A-920475
Madera	150	5 pzs.	A-920535
Madera	80	10 pzs.	007430-0
Madera	100	10 pzs.	007431-0
Madera	150	10 pzs.	007432-0

Lija 1/4" de hoja normal



Usar en	Grano	Empaque Piezas	No. Parte
Madera	60	10 pzs.	P-32904
Madera	100	10 pzs.	P-32910
Madera	120	10 pzs.	P-32926
Madera	150	10 pzs.	P-32932

Lija 1/4" de hoja con velcro perforada



Usar en	Grano	Empaque Piezas	No. Parte
Madera	40	paq. 10 pzs.	P-33087
Madera	60	paq. 10 pzs.	P-33093
Madera	80	paq. 10 pzs.	P-33102
Madera	100	paq. 10 pzs.	P-33118
Madera	120	paq. 10 pzs.	P-33124
Madera	150	paq. 10 pzs.	P-33130
Madera	180	paq. 10 pzs.	P-33146
Madera	240	paq. 10 pzs.	P-33152
Madera	320	paq. 10 pzs.	P-33168

Lija 1/4" de hoja con velcro perforada



Usar en	Grano	Empaque Piezas	No. Parte
Madera pintura	40	paq. 10 pzs.	P-35807
Madera pintura	60	paq. 10 pzs.	P-35813
Madera pintura	80	paq. 10 pzs.	P-35829
Madera pintura	100	paq. 10 pzs.	P-35835
Madera pintura	120	paq. 10 pzs.	P-35841

Lija 1/4" de hoja con velcro perforada

Usar en	Grano	Empaque Piezas	No. Parte
Madera pintura	150	paq. 10 pzs.	P-35857
Madera pintura	180	paq. 10 pzs.	P-35863
Madera pintura	240	paq. 10 pzs.	P-35879
Madera pintura	320	paq. 10 pzs.	P-35885

Lija 1/3" de hoja con velcro



Usar en	Grano	Empaque Piezas	No. Parte
Madera (con perforaciones)	40	Paq. 10 pzs.	P-31871
Madera (con perforaciones)	60	Paq. 10 pzs.	P-31887
Madera (con perforaciones)	80	Paq. 10 pzs.	P-31893
Madera (con perforaciones)	100	Paq. 10 pzs.	P-31902
Madera (con perforaciones)	240	Paq. 50 pzs.	P-36005

Lija 1/3" de hoja normal



Usar en	Grano	Empaque Piezas	No. Parte
Madera (con perforaciones)	40	Paq. 10 pzs.	P-31837
Madera (con perforaciones)	60	Paq. 10 pzs.	P-31843
Madera (con perforaciones)	80	Paq. 10 pzs.	P-31859
Madera (con perforaciones)	100	Paq. 10 pzs.	P-31865
Madera (con perforaciones)	120	Paq. 10 pzs.	P-36011
Madera (con perforaciones)	150	Paq. 10 pzs.	P-36027
Madera (con perforaciones)	180	Paq. 10 pzs.	P-36033
Madera (con perforaciones)	240	Paq. 10 pzs.	P-36049
Madera (con perforaciones)	60	Paq. 10 pzs.	P-32948

Lija de 1/2" hoja con velcro



Usar en	Grano	Empaque Piezas	No. Parte
Madera (con 6 perforaciones)	40	Paq. 10 pzs.	P-33009
Madera (con 6 perforaciones) normal	60	Paq. 10 pzs.	P-33015
Madera (con 6 perforaciones) normal	80	Paq. 10 pzs.	P-33021
Madera (con 6 perforaciones) normal	100	Paq. 10 pzs.	P-33037

El equipo estándar (accesorios), las especificaciones y las fotografías pueden variar. Los accesorios pueden no estar incluidos desde origen con las herramientas aunque se indiquen en este catálogo.

Lija de 1/2" hoja con velcro



Usar en	Grano	Empaque Piezas	No. Parte
Madera (con 6 perforaciones) normal	120	paq. 10 pzs.	P-33043
Madera (con 6 perforaciones) normal	150	paq. 10 pzs.	P-33059
Madera (con 6 perforaciones) normal	180	paq. 10 pzs.	P-33065
Madera (con 6 perforaciones) normal	240	paq. 10 pzs.	P-33071

Línea estándar

Lija perforada con velcro Para madera 5"



Usar en	Grano	Empaque Piezas	No. Parte
Madera	40	paq. 10 pzs.	D-54134
Madera	60	paq. 10 pzs.	D-54140
Madera	80	paq. 10 pzs.	D-54156
Madera	100	paq. 10 pzs.	D-54162
Madera	120	paq. 10 pzs.	D-54178
Madera	150	paq. 10 pzs.	D-54184
Madera	180	paq. 10 pzs.	D-54190
Madera	240	paq. 10 pzs.	D-54209
Madera	320	paq. 10 pzs.	D-54215

Lija perforada con velcro Para madera 5"



Disco de lijas

Usar en	Grano	Empaque Piezas	No. Parte
Madera y metal	40	paq. 5 pzs.	742137-A
Madera y metal	60	paq. 5 pzs.	794518-8
Madera y metal	80	paq. 5 pzs.	794519-6
Madera y metal	100	paq. 5 pzs.	794523-A
Madera y metal	120	paq. 5 pzs.	794520-1
Madera y metal	180	paq. 5 pzs.	794521-9
Madera y metal	240	paq. 5 pzs.	794522-7

Lija perforada con velcro Para madera 5"

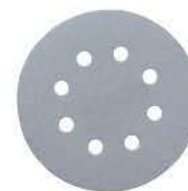

Disco de lijas

Usar en	Grano	Empaque Piezas	No. Parte
Madera y metal	320	paq. 5 pzs.	742526-A
Madera y metal	400	paq. 5 pzs.	742527-A
Madera y metal	80	paq. 5 pzs.	794609-5
Madera y metal	120	paq. 5 pzs.	794544-7
Madera y metal	40	paq. 10 pzs.	P-43533
Madera y metal	60	paq. 10 pzs.	P-43549
Madera y metal	80	paq. 10 pzs.	P-43555
Madera y metal	100	paq. 10 pzs.	P-43561
Madera y metal	120	paq. 10 pzs.	P-43577
Madera y metal	180	paq. 10 pzs.	P-43583
Madera	240	paq. 10 pzs.	P-43599
Madera	320	paq. 10 pzs.	P-43608
Madera	400	paq. 10 pzs.	P-43614
Madera	40	paq. 50 pzs.	P-43620
Madera	60	paq. 50 pzs.	P-43636
Madera	80	paq. 50 pzs.	P-43642
Madera	100	paq. 50 pzs.	P-43658
Madera	120	paq. 50 pzs.	P-43664
Madera	180	paq. 50 pzs.	P-43670
Madera	240	paq. 50 pzs.	P-43686
Madera	320	paq. 50 pzs.	P-43692
Madera	400	paq. 50 pzs.	P-43701

Disco de lija de velcro 5"

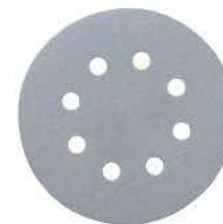

Usar en	Grano	Empaque Piezas	No. Parte
Madera y metal	40	Paq. 50 pzs.	742137-A50
Madera y metal	60	Paq. 50 pzs.	794518-8-50
Madera y metal	80	Paq. 50 pzs.	794519-6-50
Madera y metal	100	Paq. 50 pzs.	794523-A50
Madera y metal	120	Paq. 50 pzs.	794520-1-50
Madera y metal	180	Paq. 50 pzs.	794521-9-50
Madera y metal	240	Paq. 50 pzs.	794522-7-50
Madera y metal	320	Paq. 50 pzs.	742526-A50
Madera y metal	400	Paq. 50 pzs.	742527-A50

ACCESORIOS

Disco de lija liso
(sin perforaciones) 6"



Usar en	Grano	Empaque Piezas	No. Parte
Madera	40	Paq. 5 pzs.	A-92184-5
Madera	150	Paq. 5 pzs.	A-92075-5
Madera	180	Paq. 5 pzs.	A-92081-5
Madera	220	Paq. 5 pzs.	A-92097-5
Madera	320	Paq. 5 pzs.	A-92106-5
Madera	360	Paq. 5 pzs.	A-92112-5
Madera	360	Paq. 5 pzs.	A-92128-5
Madera	600	Paq. 5 pzs.	A-92271-5
Madera	1000	Paq. 5 pzs.	A-92293-5
Madera	1200	Paq. 5 pzs.	A-92302-5
Madera	1500	Paq. 5 pzs.	A-92318-5
Madera	80	Paq. 10 pzs.	794609-5

Línea estándar

Disco de lija de velcro 6"



Usar en	Grano	Empaque Piezas	No. Parte
Madera	40	paq. 10 pzs.	D-54221
Madera	60	paq. 10 pzs.	D-54237
Madera	80	paq. 10 pzs.	D-54243
Madera	100	paq. 10 pzs.	D-54259
Madera	120	paq. 10 pzs.	D-54265
Madera	150	paq. 10 pzs.	D-54271
Madera	180	paq. 10 pzs.	D-54287
Madera	240	paq. 10 pzs.	D-54293
Madera	320	paq. 10 pzs.	D-54302
Madera	40	paq. 50 pzs.	D-54405
Madera	60	paq. 50 pzs.	D-54411
Madera	80	paq. 50 pzs.	D-54427
Madera	100	paq. 50 pzs.	D-54433
Madera	120	paq. 50 pzs.	D-54449
Madera	150	paq. 50 pzs.	D-54455
Madera	240	paq. 50 pzs.	D-54477
Madera	320	paq. 50 pzs.	D-54483

Productos de lija y fibra

Disco de lija de velcro 6"
(Con 8 perforaciones)



Usar en	Grano	Empaque Piezas	No. Parte
Pintura	40	paq. 10 pzs.	P-37839
Pintura	60	paq. 10 pzs.	P-37845
Pintura	80	paq. 10 pzs.	P-37851
Pintura	100	paq. 10 pzs.	P-37867
Pintura	120	paq. 10 pzs.	P-37873
Pintura	150	paq. 10 pzs.	P-37889
Pintura	240	paq. 10 pzs.	P-37910

Disco de lija de velcro 6"
(con 6 perforaciones)



Usar en	Grano	Empaque Piezas	No. Parte
Madera	40	paq. 50 pzs.	P-37568
Madera	60	paq. 50 pzs.	P-37574
Madera	80	paq. 50 pzs.	P-37580
Madera	100	paq. 50 pzs.	P-37596
Madera	120	paq. 50 pzs.	P-37605
Madera	180	paq. 50 pzs.	P-37611
Madera	240	paq. 50 pzs.	P-37627
Madera	320	paq. 50 pzs.	P-37633
Madera	400	paq. 50 pzs.	P-37649
Pintura	40	paq. 50 pzs.	P-37742
Pintura	60	paq. 50 pzs.	P-37758
Pintura	80	paq. 50 pzs.	P-37764
Pintura	100	paq. 50 pzs.	P-37770
Pintura	120	paq. 50 pzs.	P-37786
Pintura	180	paq. 50 pzs.	P-37792
Pintura	240	paq. 50 pzs.	P-37801
Pintura	320	paq. 50 pzs.	P-37817
Pintura	400	paq. 50 pzs.	P-37823

El equipo estándar (accesorios), las especificaciones y las fotografías pueden variar. Los accesorios pueden no estar incluidos desde origen con las herramientas aunque se indiquen en este catálogo.

Disco de lija de velcro 6" (multipropósitos)



Usar en	Grano	Empaque Piezas	No. Parte
Madera, pintura y metal	40	paq.100 pzs.	B-39300
Madera, pintura y metal	60	paq.100 pzs.	B-39316
Madera, pintura y metal	80	paq.100 pzs.	B-39322
Madera, pintura y metal	120	paq.100 pzs.	B-39344

Disco de lija de velcro 6" (con 6 perforaciones)



Usar en	Grano	Empaque Piezas	No. Parte
Madera (con 6 perforaciones)	40	paq. 10 pzs.	P-37471
Madera (con 6 perforaciones)	60	paq. 10 pzs.	P-37487
Madera (con 6 perforaciones)	80	paq. 10 pzs.	P-37493
Madera (con 6 perforaciones)	100	paq. 10 pzs.	P-37502
Madera (con 6 perforaciones)	120	paq. 10 pzs.	P-37518
Madera (con 6 perforaciones)	180	paq. 10 pzs.	P-37524
Madera (con 6 perforaciones)	240	paq. 10 pzs.	P-37530
Madera (con 6 perforaciones)	320	paq. 10 pzs.	P-37546
Madera (con 6 perforaciones)	400	paq. 10 pzs.	P-37552
Madera (con 8 perforaciones)	40	paq. 10 pzs.	P-31918
Madera (con 8 perforaciones)	60	paq. 10 pzs.	P-31924
Madera (con 8 perforaciones)	80	paq. 10 pzs.	P-31930
Madera (con 8 perforaciones)	100	paq. 10 pzs.	P-31946
Madera (con 8 perforaciones)	120	paq. 10 pzs.	P-31952
Madera (con 8 perforaciones)	150	paq. 10 pzs.	P-31968
Madera (con 8 perforaciones)	180	paq. 10 pzs.	P-31974
Madera (con 8 perforaciones)	220	paq. 10 pzs.	P-31980
Madera (con 8 perforaciones)	240	paq. 10 pzs.	P-31996
Madera (con 8 perforaciones)	320	paq. 10 pzs.	P-32007
Madera (con 8 perforaciones)	400	paq. 10 pzs.	P-32013
Madera	40	paq. 50 pzs.	P-32574
Madera	60	paq. 50 pzs.	P-32580
Madera	80	paq. 50 pzs.	P-32596
Madera	100	paq. 50 pzs.	P-32605
Madera	120	paq. 50 pzs.	P-32611
Madera	180	paq. 50 pzs.	P-32633
Madera	240	paq. 50 pzs.	P-32655
Madera	320	paq. 50 pzs.	P-32661
Madera	400	paq. 50 pzs.	P-32677

Disco de lija de velcro 6" (con 15 perforaciones) para madera



Usar en	Grano	Empaque Piezas	No. Parte
Madera	40	paq. 10 pzs.	B-51415
Madera	60	paq. 10 pzs.	B-51421
Madera	80	paq. 10 pzs.	B-51437
Madera	100	paq. 10 pzs.	B-51443
Madera	120	paq. 10 pzs.	B-51459
Madera	180	paq. 10 pzs.	B-51465
Madera	240	paq. 10 pzs.	B-51471
Madera	320	paq. 10 pzs.	B-51487
Madera	400	paq. 10 pzs.	B-51493

Disco de lija de velcro 6" (con 15 perforaciones) para pintura



Usar en	Grano	Empaque Piezas	No. Parte
Pintura	40	paq. 10 pzs.	B-51502
Pintura	60	paq. 10 pzs.	B-51518
Pintura	80	paq. 10 pzs.	B-51524
Pintura	100	paq. 10 pzs.	B-51530
Pintura	120	paq. 10 pzs.	B-51546
Pintura	180	paq. 10 pzs.	B-51552
Pintura	240	paq. 10 pzs.	B-51568
Pintura	320	paq. 10 pzs.	B-51574
Pintura	400	paq. 10 pzs.	B-51580

Disco de lija para piedra

Pulido de superficies de piedra con pulidora PK5001C ó PK5011C



Diámetro	Grano	Empaque Piezas	No. Parte
5"	24	paq. 5 pzs.	B-14526
5"	50	paq. 5 pzs.	B-14532
5"	80	paq. 5 pzs.	B-14548
5"	120	paq. 5 pzs.	B-14554

Disco de lija de oxido de aluminio para metal

Para esmeriladoras angulares 4-1/2" y 5"



Diámetro	Grano	Empaque Piezas	No. Parte
4-1/2"	16	paq. 5 pzs.	P-00854
4-1/2"	24	paq. 5 pzs.	P-00860
4-1/2"	36	paq. 5 pzs.	P-00876
4-1/2"	40	paq. 5 pzs.	P-00882
4-1/2"	50	paq. 5 pzs.	P-00898
4-1/2"	60	paq. 5 pzs.	P-00907
4-1/2"	80	paq. 5 pzs.	P-00913
4-1/2"	100	paq. 5 pzs.	P-00929
4-1/2"	120	paq. 5 pzs.	P-00935
5"	24	paq. 5 pzs.	P-00957
5"	36	paq. 5 pzs.	P-00963
5"	40	paq. 5 pzs.	P-00979
5"	80	paq. 5 pzs.	P-00991
5"	100	paq. 5 pzs.	P-01002
5"	120	paq. 5 pzs.	P-01018

Discos de lija para esmeril (7")



Diámetro	Grano	Empaque Piezas	No. Parte
180mm (7")	24	paq. 25 pzs.	P-43804
180mm (7")	36	paq. 25 pzs.	P-43810
180mm (7")	40	paq. 25 pzs.	P-43826
180mm (7")	50	paq. 25 pzs.	P-43832
180mm (7")	60	paq. 25 pzs.	P-43848
180mm (7")	80	paq. 25 pzs.	P-43854
180mm (7")	100	paq. 25 pzs.	P-43860
180mm (7")	120	paq. 25 pzs.	P-43876
180mm (7")	150	paq. 25 pzs.	P-43882



El equipo estándar (accesorios), las especificaciones y las fotografías pueden variar. Los accesorios pueden no estar incluidos desde origen con las herramientas aunque se indiquen en este catálogo.

Discos de fibra



Material	Eje	Grano	Diámetro	Empaque Piezas	No. Parte
Metal / inox	7/8"	Ligero	4-1/2"	1	B-36619
Metal / inox	7/8"	Long Life	4-1/2"	1	B-36653
Metal / inox	7/8"	Ligero	7"	1	B-36631
Metal / inox	7/8"	Long Life	7"	1	B-36675

Multidiscos insertados

Uso general

Línea profesional



Lijado y esmerilado de metales, maderas, plásticos y acero sin pintura.

Material	Eje	Diámetro	Grano	Empaque Piezas	No. Parte
Metal / inox	7/8"	4-1/2"	40	1	B-06345
Metal / inox	7/8"	4-1/2"	60	1	B-06351
Metal / inox	7/8"	4-1/2"	80	1	B-06367
Metal / inox	7/8"	4-1/2"	120	1	B-06373
Metal / inox	7/8"	7"	40	1	B-06395
Metal / inox	7/8"	7"	60	1	B-06404
Metal / inox	7/8"	7"	80	1	B-06410
Metal / inox	7/8"	7"	120	1	B-06426

Multidiscos abrasivos angulares de zirconia para acero inoxidable

Línea industrial



Para uso pesado en metales ferrosos y acero inoxidable

Material	Eje	Diámetro	Grano	Empaque Piezas	No. Parte
Metal / inox	7/8"	4-1/2"	40	1	B-34160
Metal / inox	7/8"	4-1/2"	60	1	B-34176
Metal / inox	7/8"	4-1/2"	80	1	B-34182
Metal / inox	7/8"	4-1/2"	120	1	B-34198
Metal / inox	7/8"	7"	40	1	B-34241
Metal / inox	7/8"	7"	60	1	B-34257
Metal / inox	7/8"	7"	80	1	B-34263
Metal / inox	7/8"	7"	120	1	B-34279

Multidiscos abrasivos angulares de zirconia

Línea industrial



Para uso pesado en metales ferrosos y acero inoxidable

Material	Eje	Diámetro	Grano	Empaque Piezas	No. Parte
Metal		4-1/2"	40	1	B-55603
Metal		4-1/2"	60	1	B-55619
Metal		4-1/2"	80	1	B-55625
Metal		4-1/2"	120	1	B-55631
Metal		4-1/2"	40	1	B-55647
Metal		4-1/2"	60	1	B-55653
Metal		4-1/2"	80	1	B-55669
Metal		4-1/2"	120	1	B-55675

Multidiscos abrasivos angulares de zirconia para acero inoxidable

Línea estandar



Material	Eje	Diámetro	Grano	Empaque Piezas	No. Parte
Metal / inox	7/8"	4-1/2"	36	1	D-53861
Metal / inox	7/8"	4-1/2"	40	1	D-53877
Metal / inox	7/8"	4-1/2"	60	1	D-53883
Metal / inox	7/8"	4-1/2"	80	1	D-53899
Metal / inox	7/8"	4-1/2"	120	1	D-53908
Metal / inox	7/8"	5"	36	1	D-53914
Metal / inox	7/8"	5"	40	1	D-53920
Metal / inox	7/8"	5"	60	1	D-53936
Metal / inox	7/8"	5"	80	1	D-53942
Metal / inox	7/8"	5"	120	1	D-53958
Metal / inox	7/8"	7"	36	1	D-53964
Metal / inox	7/8"	7"	40	1	D-53970
Metal / inox	7/8"	7"	60	1	D-53986
Metal / inox	7/8"	7"	80	1	D-53992
Metal / inox	7/8"	7"	120	1	D-54003

Multidiscos abrasivos angulares de zirconia para acero inoxidable

Línea estandar



Material	Eje	Diámetro	Grano	Empaque Piezas	No. Parte
Metal / inox	7/8"	4-1/2"	Z40	1	D-63747
Metal / inox	7/8"	4-1/2"	Z60	1	D-63753
Metal / inox	7/8"	4-1/2"	Z80	1	D-63769
Metal / inox	7/8"	4-1/2"	Z120	1	D-63775
Metal / inox	7/8"	5"	Z40	1	D-63781
Metal / inox	7/8"	5"	Z60	1	D-63797
Metal / inox	7/8"	5"	Z80	1	D-63806
Metal / inox	7/8"	5"	Z120	1	D-63812
Metal / inox	7/8"	7"	Z40	1	D-63828
Metal / inox	7/8"	7"	Z60	1	D-63834
Metal / inox	7/8"	7"	Z80	1	D-63840
Metal / inox	7/8"	7"	Z120	1	D-63856

Multidiscos insertados uso general

Para uso pesado en metales ferrosos y acero inoxidable

LONG LIFE



Material	Eje	Diámetro	Grano	Empaque Piezas	No. Parte
Metal / inox	7/8"	4-1/2"	40	1	B-34285
Metal / inox	7/8"	4-1/2"	60	1	B-34291
Metal / inox	7/8"	4-1/2"	80	1	B-34300
Metal / inox	7/8"	4-1/2"	120	1	B-34316
Metal / inox	7/8"	7"	40	1	B-34366
Metal / inox	7/8"	7"	60	1	B-34372
Metal / inox	7/8"	7"	80	1	B-34388
Metal / inox	7/8"	7"	120	1	B-34394

ACCESORIOS

Multidiscos insertado Para madera y metal



Material	Eje	Diámetro	Grano	Empaque Piezas	No. Parte
Metal, plástico y madera	7/8"	4-1/2"	40	1	D-32007
Metal, plástico y madera	7/8"	4-1/2"	60	1	D-32013
Metal, plástico y madera	7/8"	4-1/2"	80	1	D-32029
Metal, plástico y madera	7/8"	4-1/2"	120	1	D-32035
Metal, plástico y madera	7/8"	7"	40	1	D-32041
Metal, plástico y madera	7/8"	7"	60	1	D-32057
Metal, plástico y madera	7/8"	7"	80	1	D-32063
Metal, plástico y madera	7/8"	7"	120	1	D-32079
Concreto	7/8"	4-1/2"	40	1	D-31946
Concreto	7/8"	4-1/2"	60	1	D-31952
Concreto	7/8"	4-1/2"	80	1	D-31968
Acero inoxidable, alto rendimiento	7/8"	4-1/2"	40	1	D-31974
Acero inoxidable, alto rendimiento	7/8"	4-1/2"	60	1	D-31980
Acero inoxidable, alto rendimiento	7/8"	4-1/2"	80	1	D-31996
Acero inoxidable	7/8"	4-1/2"	40	1	D-32085
Acero inoxidable	7/8"	4-1/2"	60	1	D-32091
Acero inoxidable	7/8"	4-1/2"	80	1	D-32100
Acero inoxidable	7/8"	4-1/2"	120	1	D-32493

Multidiscos insertado Para metal y PVC

Material	Eje	Diámetro	Grano	Empaque Piezas	No. Parte
Metal, PVC	7/8"	4-1/2"	40	1	D-63432
Metal, PVC	7/8"	4-1/2"	60	1	D-63448
Metal, PVC	7/8"	4-1/2"	80	1	D-63454
Metal, PVC	7/8"	4-1/2"	120	1	D-63460
Metal, PVC	7/8"	5"	40	1	D-63476
Metal, PVC	7/8"	5"	60	1	D-63482
Metal, PVC	7/8"	5"	80	1	D-63498
Metal, PVC	7/8"	5"	120	1	D-63507
Metal, PVC	7/8"	7"	40	1	D-63513
Metal, PVC	7/8"	7"	60	1	D-63529
Metal, PVC	7/8"	7"	80	1	D-63535
Metal, PVC	7/8"	7"	120	1	D-63541

Productos de lija y fibra

Discos de fibra Para inoxidable



Descripción	Diámetro	Tipo	Empaque Piezas	No. Parte
Disco de fibra	4-1/2"	Grueso con ángulo	1	B-41713
Disco de fibra	4-1/2"	Medio con ángulo	1	B-41729
Disco de fibra	4-1/2"	Fino con ángulo	1	B-41735
Disco de fibra	4-1/2"	Ultra-fino con ángulo	1	B-41741
Disco de fibra	5"	Grueso con ángulo	1	B-41757
Disco de fibra	5"	Medio con ángulo	1	B-41763
Disco de fibra	5"	Fino con ángulo	1	B-41779
Disco de fibra	5"	Ultra-fino con ángulo	1	B-41785
Disco de fibra	7"	Grueso con ángulo	1	B-41791
Disco de fibra	7"	Medio con ángulo	1	B-41800
Disco de fibra	7"	Fino con ángulo	1	B-41816
Disco de fibra	7"	Ultra-fino con ángulo	1	B-41822
Disco de fibra	4-1/2"	Grueso flat	1	B-41872
Disco de fibra	4-1/2"	Medio flat	1	B-41888
Disco de fibra	4-1/2"	Fino flat	1	B-41894
Disco de fibra	4-1/2"	Ultra-fino flat	1	B-41903
Disco de fibra	5"	Grueso flat	1	B-41919
Disco de fibra	5"	Medio flat	1	B-41925
Disco de fibra	5"	Fino flat	1	B-41931
Disco de fibra	5"	Ultra-fino flat	1	B-41947
Disco de fibra	7"	Grueso flat	1	B-41953
Disco de fibra	7"	Medio flat	1	B-41969
Disco de fibra	7"	Fino flat	1	B-41975
Disco de fibra	7"	Ultra-fino flat	1	B-41981

Discos de lija para piedra y mármol 7"



Usar en	Grano	Empaque Piezas	No. Parte
Lijadoras y esmeriladoras 7"	120	Paq. 5pz.	A-92623-5
Lijadoras y esmeriladoras 7"	24	Paq. 5pz.	A-92798-5
Lijadoras y esmeriladoras 7"	36	Paq. 5pz.	A-92807-5
Lijadoras y esmeriladoras 7"	60	Paq. 5pz.	A-92813-5
Lijadoras y esmeriladoras 7"	120	Paq. 5pz.	A-92829-5
Lijadoras y esmeriladoras 7"	180	Paq. 5pz.	A-92835-5

El equipo estándar (accesorios), las especificaciones y las fotografías pueden variar. Los accesorios pueden no estar incluidos desde origen con las herramientas aunque se indiquen en este catálogo.

Discos de lija para aluminio



Usar en	Grano	Empaque Piezas	No. Parte
Lijadoras y esmeriladoras 7"	24	Paq. 5Pzs.	A-92885-5
Lijadoras y esmeriladoras 7"	36	Paq. 5Pzs.	A-92891-5
Lijadoras y esmeriladoras 7"	50	Paq. 5Pzs.	A-92841-5
Lijadoras y esmeriladoras 7"	50	Paq. 5Pzs.	A-92900-5
Lijadoras y esmeriladoras 7"	60	Paq. 5Pzs.	A-92857-5
Lijadoras y esmeriladoras 7"	60	Paq. 5Pzs.	A-92916-5
Lijadoras y esmeriladoras 7"	80	Paq. 5Pzs.	A-92863-5
Lijadoras y esmeriladoras 7"	80	Paq. 5Pzs.	A-92922-5
Lijadoras y esmeriladoras 7"	100	Paq. 5Pzs.	A-92879-5
Lijadoras y esmeriladoras 7"	100	Paq. 5Pzs.	A-92938-5

Discos de lija para acero



Usar en	Grano	Empaque piezas	No. Parte
Esmeriladoras 7"	60	Paq. 5Pzs.	A-92592-5
Esmeriladoras 7"	80	Paq. 5Pzs.	A-92710-5
Esmeriladoras 7"	80	Paq. 5Pzs.	A-92601-5
Esmeriladoras 7"	100	Paq. 5Pzs.	A-92726-5
Esmeriladoras 7"	100	Paq. 5Pzs.	A-92617-5
Esmeriladoras 7"	120	Paq. 5Pzs.	A-92732-5
Esmeriladoras 4-1/2"	16	Paq. 5Pzs.	A-92667-5
Esmeriladoras 4-1/2"	24	Paq. 5Pzs.	A-92673-5
Esmeriladoras 4-1/2"	36	Paq. 5Pzs.	A-92689-5
Esmeriladoras 4-1/2"	50	Paq. 5Pzs.	A-92748-5
Esmeriladoras 4-1/2"	60	Paq. 5Pzs.	A-92754-5
Esmeriladoras 4-1/2"	80	Paq. 5Pzs.	A-92760-5
Esmeriladoras 4-1/2"	100	Paq. 5Pzs.	A-92776-5
Esmeriladoras 4-1/2"	120	Paq. 5Pzs.	A-92782-5
Esmeriladoras 7"	16	Paq. 5Pzs.	A-92558-5
Esmeriladoras 7"	16	Paq. 5Pzs.	A-92639-5
Esmeriladoras 7"	24	Paq. 5Pzs.	A-92564-5
Esmeriladoras 7"	24	Paq. 5Pzs.	A-92645-5
Esmeriladoras 7"	36	Paq. 5Pzs.	A-92570-5
Esmeriladoras 7"	36	Paq. 5Pzs.	A-92651-5
Esmeriladoras 7"	50	Paq. 5Pzs.	A-92695-5
Esmeriladoras 7"	50	Paq. 5Pzs.	A-92586-5
Esmeriladoras 7"	60	Paq. 5Pzs.	A-92704-5

Lijas de banda

Lijas de banda para madera 1/4"x21"



Usar en	Grano	Empaque piezas	No. Parte
Madera	40	Paquete con 5 Pzs.	P-43181
Madera	60	Paquete con 5 Pzs.	P-43197
Madera	80	Paquete con 5 Pzs.	P-43206
Madera	100	Paquete con 5 Pzs.	P-43212
Madera	120	Paquete con 5 Pzs.	P-43228
Madera	150	Paquete con 5 Pzs.	P-43234
Madera	240	Paquete con 5 Pzs.	P-43240
Madera	80	Paquete con 10 Pzs.	A-34534
Madera	100	Paquete con 10 Pzs.	A-34540
Madera	120	Paquete con 10 Pzs.	A-34556

Lijas de banda para madera 1/2"x21"



Usar en	Grano	Empaque piezas	No. Parte
Madera	40	Paquete con 5 Pzs.	P-43321
Madera	60	Paquete con 5 Pzs.	P-43337
Madera	80	Paquete con 5 Pzs.	P-43343
Madera	100	Paquete con 5 Pzs.	P-43359
Madera	120	Paquete con 5 Pzs.	P-43365
Madera	150	Paquete con 5 Pzs.	P-43371
Madera	240	Paquete con 5 Pzs.	P-43387
Madera	40	Paquete con 10 Pzs.	A-34562
Madera	60	Paquete con 10 Pzs.	A-34578
Madera	80	Paquete con 10 Pzs.	A-34584
Madera	100	Paquete con 10 Pzs.	A-34590
Madera	120	Paquete con 10 Pzs.	A-34609

ACCESORIOS

Lijas de banda para madera, metal inox 3/8"x21"



Usar en	Grano	Empaque piezas	No. Parte
Madera	40	Paquete con 5 Pzs	P-43256
Madera	60	Paquete con 5 Pzs	P-43262
Madera	80	Paquete con 5 Pzs	P-43278
Madera	100	Paquete con 5 Pzs	P-43284
Madera	120	Paquete con 5 Pzs	P-43290
Madera	150	Paquete con 5 Pzs	P-43309
Madera	240	Paquete con 5 Pzs	P-43315
Madera	40	Paquete con 10 Pzs	A-34447
Madera	60	Paquete con 10 Pzs	A-34453
Madera	80	Paquete con 10 Pzs	A-34469
Madera	100	Paquete con 10 Pzs	A-34475
Madera	120	Paquete con 10 Pzs	A-34481
Madera	80	Paquete con 25 Pzs	P-39453
Metal inox	40	Paquete con 25 Pzs	P-39431
Metal inox	60	Paquete con 25 Pzs	P-39447
Metal inox	100	Paquete con 25 Pzs	P-39469
Metal inox	120	Paquete con 25 Pzs	P-39475

Lijas de banda para madera, metal inox 1- 3/16"x21"



Usar en	Grano	Empaque piezas	No. Parte
Madera	40	Paquete con 5 Pzs	P-36675
Madera	60	Paquete con 5 Pzs	P-36681
Madera	80	Paquete con 5 Pzs	P-36697
Madera	100	Paquete con 5 Pzs	P-36706
Madera	120	Paquete con 5 Pzs	P-36712

Productos de lija y fibra

Lijas de banda para madera, metal inox 1- 3/16"x21"



Usar en	Grano	Empaque piezas	No. Parte
Madera	150	Paquete con 5 Pzs	P-36728
Madera	240	Paquete con 5 Pzs	P-36734
Madera	40	Paquete con 10 Pzs	A-91665-10
Madera	60	Paquete con 10 Pzs	A-91671-10
Madera	80	Paquete con 10 Pzs	A-91481-10
Madera	100	Paquete con 10 Pzs	A-91497-10
Madera	120	Paquete con 10 Pzs	A-91506-10
Metal inox	150	Paquete con 10 Pzs	A-91512-10
Metal inox	40	Paquete con 5 Pzs	P-00088
Metal inox	60	Paquete con 5 Pzs	P-00094
Metal inox	80	Paquete con 5 Pzs	P-00103
Metal inox	100	Paquete con 5 Pzs	P-00119
Metal inox	120	Paquete con 5 Pzs	P-00125
Metal inox	150	Paquete con 5 Pzs	P-00131

Lijas de banda para piedra 1-3/16"x21"



Usar en	Grano	Empaque piezas	No. Parte
Piedra	40	Paquete con 5 Pzs	P-01395
Piedra	60	Paquete con 5 Pzs	P-01404
Piedra	80	Paquete con 5 Pzs	P-01199
Piedra	100	Paquete con 5 Pzs	P-01208
Piedra	120	Paquete con 5 Pzs	P-01214
Piedra	150	Paquete con 5 Pzs	P-01220
Piedra	180	Paquete con 5 Pzs	P-01236

El equipo estándar (accesorios), las especificaciones y las fotografías pueden variar. Los accesorios pueden no estar incluidos desde origen con las herramientas aunque se indiquen en este catálogo.

Lijas de banda para madera, vidrio 3"x18"



Usar en	Grano	Empaque Piezas	No. Parte
Madera	40	Paquete con 10 Pzs	A-91687-10
Madera	50	Paquete con 10 Pzs	A-91693-10
Madera	60	Paquete con 10 Pzs	A-91702-10
Madera	80	Paquete con 10 Pzs	A-91528-10
Madera	100	Paquete con 10 Pzs	A-91534-10
Madera	120	Paquete con 10 Pzs	A-91540-10
Madera	40	Paquete con 5 Pzs	P-37091
Madera	60	Paquete con 5 Pzs	P-37100
Madera	80	Paquete con 5 Pzs	P-37116
Madera	100	Paquete con 5 Pzs	P-37122
Madera	120	Paquete con 5 Pzs	P-37138
Madera	150	Paquete con 5 Pzs	P-37144
Madera	240	Paquete con 5 Pzs	P-37150
Madera	40/60/120	Paquete 3 Pzs 1 c/u	P-37166
Vidrio	60	Paquete con 10 Pzs	A-91914-10
Vidrio	80	Paquete con 10 Pzs	A-91920-10
Vidrio	100	Paquete con 10 Pzs	A-91936-10
Vidrio	120	Paquete con 10 Pzs	A-91942-10
Vidrio	180	Paquete con 10 Pzs	A-91958-10
Vidrio	220	Paquete con 10 Pzs	A-91964-10

Lijas línea estándar para madera, metal y PVC 3"x18"



Usar en	Grano	Empaque Piezas	No. Parte
Madera, metal y PVC	40	Paquete con 3 Pzs.	D-59184
Madera, metal y PVC	60	Paquete con 3 Pzs.	D-59190
Madera, metal y PVC	80	Paquete con 3 Pzs.	D-59209
Madera, metal y PVC	100	Paquete con 3 Pzs.	D-59215
Madera, metal y PVC	120	Paquete con 3 Pzs.	D-59221
Madera, metal y PVC	150	Paquete con 3 Pzs.	D-59237
Madera, metal y PVC	180	Paquete con 3 Pzs.	D-59243
Madera, metal y PVC	240	Paquete con 3 Pzs.	D-59259

Lijas línea estándar Para madera, metal y PVC 3x21"



Usar en	Grano	Empaque piezas	No. Parte
Madera, metal y PVC	40	Paquete con 3 Pzs.	D-59265
Madera, metal y PVC	60	Paquete con 3 Pzs.	D-59271
Madera, metal y PVC	80	Paquete con 3 Pzs.	D-59287
Madera, metal y PVC	100	Paquete con 3 Pzs.	D-59293
Madera, metal y PVC	120	Paquete con 3 Pzs.	D-59302
Madera, metal y PVC	150	Paquete con 3 Pzs.	D-59318
Madera, metal y PVC	180	Paquete con 3 Pzs.	D-59324
Madera, metal y PVC	240	Paquete con 3 Pzs.	D-59330

Lijas de banda para metal 3"x24"



Usar en	Grano	Empaque piezas	No. Parte
Metal	60	Paquete con 10 Pzs.	A-91861-10
Metal	80	Paquete con 10 Pzs.	A-91877-10
Metal	100	Paquete con 10 Pzs.	A-91880-10
Metal	120	Paquete con 10 Pzs.	A-91899-10
Metal	150	Paquete con 10 Pzs.	A-91908-10



ACCESORIOS

Lijas de banda para madera, 3"x24"



Usar en	Grano	Empaque piezas	No. Parte
Madera	40	Paquete con 5 Pzs.	P-37312
Madera	60	Paquete con 5 Pzs.	P-37328
Madera	80	Paquete con 5 Pzs.	P-37334
Madera	100	Paquete con 5 Pzs.	P-37340
Madera	120	Paquete con 5 Pzs.	P-37356
Madera	150	Paquete con 5 Pzs.	P-37362
Madera	240	Paquete con 5 Pzs.	P-37378
Madera	40	Paquete con 10 Pzs.	A-91780-10
Madera	50	Paquete con 10 Pzs.	A-91796-10
Madera	60	Paquete con 10 Pzs.	A-91805-10
Madera	80	Paquete con 10 Pzs.	A-91621-10
Madera	100	Paquete con 10 Pzs.	A-91637-10
Madera	120	Paquete con 10 Pzs.	A-91643-10
Madera	150	Paquete con 10 Pzs.	A-91659-10

Lijas de banda para vidrio, 3"x24"



Usar en	Grano	Empaque piezas	No. Parte
Vidrio	60	Paquete con 10 Pzs.	A-91970-10
Vidrio	80	Paquete con 10 Pzs.	A-91986-10
Vidrio	100	Paquete con 10 Pzs.	A-91992-10
Vidrio	120	Paquete con 10 Pzs.	A-92003-10
Vidrio	180	Paquete con 10 Pzs.	A-92019-10
Vidrio	220	Paquete con 10 Pzs.	A-92025-10

Lijas de banda para madera 3"x21"



Usar en	Grano	Empaque piezas	No. Parte
Madera	40	Paquete con 5 Pzs.	P-37172
Madera	60	Paquete con 5 Pzs.	P-37188
Madera	80	Paquete con 5 Pzs.	P-37194
Madera	100	Paquete con 5 Pzs.	P-37203
Madera	120	Paquete con 5 Pzs.	P-37219
Madera	150	Paquete con 5 Pzs.	P-37225
Madera	240	Paquete con 5 Pzs.	P-37231

Productos de lija y fibra

Lijas de banda para madera 3"x21"



Usar en	Grano	Empaque piezas	No. Parte
Madera	40	Paquete con 10 Pzs.	A-91746-10
Madera	60	Paquete con 10 Pzs.	A-91768-10
Madera	80	Paquete con 10 Pzs.	A-91584-10
Madera	100	Paquete con 10 Pzs.	A-91590-10
Madera	120	Paquete con 10 Pzs.	A-91609-10
Madera	40	Paquete con 25 Pzs.	P-37247
Madera	60	Paquete con 25 Pzs.	P-37253
Madera	80	Paquete con 25 Pzs.	P-37269
Madera	100	Paquete con 25 Pzs.	P-37275
Madera	120	Paquete con 25 Pzs.	P-37281
Madera	150	Paquete con 25 Pzs.	P-37297
Madera	240	Paquete con 25 Pzs.	P-37306

Lijas de banda para madera 4"x24"



Usar en	Grano	Empaque piezas	No. Parte
Madera	80	Paq. 2 Pzs.	A-915562
Madera	40	Paq. 5 Pzs.	P-36887
Madera	60	Paq. 5 Pzs.	P-36893
Madera	80	Paq. 5 Pzs.	P-36902
Madera	100	Paq. 5 Pzs.	P-36918
Madera	120	Paq. 5 Pzs.	P-36924
Madera	150	Paq. 5 Pzs.	P-36930
Madera	240	Paq. 5 Pzs.	P-36946
Madera	80	Paq. 10 Pzs.	A-91556-10
Madera	120	Paq. 10 Pzs.	A-91562-10
Madera	150	Paq. 10 Pzs.	A-91578-10
Madera	40	Paq. 10 Pzs.	A-91724-10
Madera	40	Paq. 25 Pzs.	P-36952
Madera	60	Paq. 25 Pzs.	P-36968
Madera	80	Paq. 25 Pzs.	P-36974
Madera	100	Paq. 25 Pzs.	P-36980
Madera	120	Paq. 25 Pzs.	P-36996
Madera	150	Paq. 25 Pzs.	P-37007
Madera	240	Paq. 25 Pzs.	P-37013

El equipo estándar (accesorios), las especificaciones y las fotografías pueden variar. Los accesorios pueden no estar incluidos desde origen con las herramientas aunque se indiquen en este catálogo.

Lijas línea estándar para madera, metal y PVC 4x24"



Usar en	Grano	Empaque piezas	No. Parte
Madera, metal y PVC	40	Paquete con 3 Pzs.	D-59346
Madera, metal y PVC	60	Paquete con 3 Pzs.	D-59352
Madera, metal y PVC	80	Paquete con 3 Pzs.	D-59368
Madera, metal y PVC	100	Paquete con 3 Pzs.	D-59374
Madera, metal y PVC	120	Paquete con 3 Pzs.	D-59380
Madera, metal y PVC	150	Paquete con 3 Pzs.	D-59396
Madera, metal y PVC	180	Paquete con 3 Pzs.	D-59405
Madera, metal y PVC	240	Paquete con 3 Pzs.	D-59411

Conectores



Aplicación	Usar en	Empaque piezas	No. Parte
Adaptador bolsa a máquina	3901	1	415252-4
Adaptador bolsa a máquina	9401	1	192613-2
Seguro para bolsa	9901	1	410602-8

Complementos



Descripción	Usar en	Empaque piezas	No. Parte
Placa perforadora para lijas (plástica)	BO3710/3711	1	451271-6
Mango frontal	BO4051	1	451623-1
Base de empuñadura	BO5041	1	140440-1
Seguro	BO5041	1	451622-3



Accesorios para lijadoras

	Usar en	Descripción	Empaque Pieza	No. Parte
	9401 - 9402	Base fijadora para mesa	1	342332-2
	9901	Base de acero	1	343355-3
	9924B	Base de acero	1	342526-9
	BO5041	Filtro de velcro	1	794559-4
	BO5021	Borla de lana 5" con velcro	1	794560-9
	BO5030	Respaldo con velcro 5" 8 (Perforaciones)	1	743081-8
	BO5030	Esponja para pulir con velcro 5"	1	794558-6
	BO5001	Respaldo de esponja	1	743022-A
	BO5010/ 5020/ 5021	5" Respaldo liso	1	743056-7
	BO4530	5" Respaldo liso	1	743032-1
	BO6030/ BO6040	Respaldo con velcro 6" 6 (perforaciones)	1	A-87812
	SA7000C/ 9237C con adaptador D-57087	Bonete p/pulir 9" doble borla amarillo	1	D-57152
	PO5000C 197920-8	Esponja 4"	1	197912-7
		Esponja 6"	1	197914-3
		Felpa 4"	1	197916-9
		Bonete para pulir 4"	1	197918-5
		Bonete para pulir 4 1/2"	1	197920-8

ACCESORIOS

Esponjas de pulido para PO5000C



Duro

Medida	Forma	Tipo	Empaque Pieza	No. Parte
100mm	Plano	Duro	1	D-62505
125mm	Plano	Duro	1	D-62511
150mm	Plano	Duro	1	D-62527
100mm	Ondulado	Duro	1	D-62599
125mm	Ondulado	Duro	1	D-62608
150mm	Ondulado	Duro	1	D-62614

Productos de lija y fibra

Esponjas de pulido para PO5000C



Suave

Medida	Forma	Tipo	Empaque Pieza	No. Parte
100mm	Plano	Suave	1	D-62561
125mm	Plano	Suave	1	D-62577
150mm	Plano	Suave	1	D-62583
100mm	Ondulado	Suave	1	D-62658
125mm	Ondulado	Suave	1	D-62664
150mm	Ondulado	Suave	1	D-62670

Esponjas de pulido para PO5000C



Medio

Medida	Forma	Tipo	Empaque Pieza	No. Parte
100mm	Plano	Medio	1	D-62533
125mm	Plano	Medio	1	D-62549
150mm	Plano	Medio	1	D-62555
100mm	Ondulado	Medio	1	D-62620
125mm	Ondulado	Medio	1	D-62636
150mm	Ondulado	Medio	1	D-62642

kit de Pulidora automotriz PO5000CX2



Incluye:
Maleta (No parte: 831271-6)
Almohadillas de espuma 5-1/2"

El equipo estándar (accesorios), las especificaciones y las fotografías pueden variar. Los accesorios pueden no estar incluidos desde origen con las herramientas aunque se indiquen en este catálogo.

Bolsas para recolección de polvo



Aplicación	Usar en	Empaque piezas	No. Parte
Recolección del polvo de desecho generado durante el trabajo con la herramienta.	3901	1	122474-6
Recolección del polvo de desecho generado durante el trabajo con la herramienta.	9046	1	152456-4
Recolección del polvo de desecho generado durante el trabajo con la herramienta.	9401	1	122297-2
Recolección del polvo de desecho generado durante el trabajo con la herramienta.	9901	1	122329-5
Recolección del polvo de desecho generado durante el trabajo con la herramienta.	1900B	1	122230-4
Recolección del polvo de desecho generado durante el trabajo con la herramienta.	1911B	1	122402-1
Recolección del polvo de desecho generado durante el trabajo con la herramienta.	4014NV UB1101	1	122321-1
Recolección del polvo de desecho generado durante el trabajo con la herramienta.	9045N	1	122339-2
Recolección del polvo de desecho generado durante el trabajo con la herramienta.	9403, 9921	1	122562-9
Recolección del polvo de desecho generado durante el trabajo con la herramienta.	9900B, 9924DB	1	122296-4
Recolección del polvo de desecho generado durante el trabajo con la herramienta.	9902/03 /04/20	1	122591-2
Recolección del polvo de desecho generado durante el trabajo con la herramienta.	9910, 9911	1	122548-3
Recolección del polvo de desecho generado durante el trabajo con la herramienta.	B03710	1	140115-2

Bolsas para recolección de polvo



Aplicación	Usar en	Empaque piezas	No. Parte
Recolección del polvo de desecho generado durante el trabajo con la herramienta.	B04551, B04552, B04562	1	166027-1
Recolección del polvo de desecho generado durante el trabajo con la herramienta.	B04556	1	166078-4
Recolección del polvo de desecho generado durante el trabajo con la herramienta.	*	1	166079-2
Recolección del polvo de desecho generado durante el trabajo con la herramienta.	B05010	1	166047-5
Recolección del polvo de desecho generado durante el trabajo con la herramienta.	4093D BOLSA ANTIBACTERIAL	1	166084-9
Recolección del polvo de desecho generado durante el trabajo con la herramienta.	B05021	1	151517-7
Recolección del polvo de desecho generado durante el trabajo con la herramienta.	LS1011	1	122351-2
Recolección del polvo de desecho generado durante el trabajo con la herramienta.	LS1016	1	122852-0
Recolección del polvo de desecho generado durante el trabajo con la herramienta.	LS1430, LS1440	1	122330-0
Recolección del polvo de desecho generado durante el trabajo con la herramienta.	PC1100	1	122193-4
Recolección del polvo de desecho generado durante el trabajo con la herramienta.	PC1100	1	123203-0
Recolección del polvo de desecho generado durante el trabajo con la herramienta.	PC5001C	1	122853-8



RUEDAS FLAP

Especificaciones

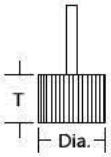

Aplicación



✓ Disponibles

Forma									
Diá. x T (mm)		25x25	38x25	50x25	50x38	50x50	64x25	75x25	75x50
Grosso	#40	✓	✓	✓ (EN)	✓ (EN)	✓ (EN)	✓ (EN)	✓ (EN)	✓ (EN)
	#60	✓	✓	✓ (EN)	✓ (EN)	✓ (EN)	✓ (EN)	✓ (EN)	✓ (EN)
Medio	#80	✓	✓	✓ (EN)	✓ (EN)	✓ (EN)	✓ (EN)	✓ (EN)	✓ (EN)
	#120	✓	✓	✓ (EN)	✓ (EN)	✓ (EN)	✓ (EN)	✓ (EN)	✓ (EN)
Fino	#180	✓	✓	✓ (EN)	✓ (EN)	✓ (EN)	✓ (EN)	✓ (EN)	✓ (EN)

Diámetro	Longitud	Zanco	Grano	No. Parte
1"	1"	1/4"	60	B-38071
			80	B-38087
			120	B-38093
1-1/2"	1"	1/4"	60	B-38124
			80	B-38130
2"	1"	1/4"	60	B-38174
			80	B-38180
			120	B-38196

Diámetro	Longitud	Zanco	Grano	No. Parte
2"	1-1/2"	1/4"	60	B-38227
			80	B-38233
			120	B-38249
2"	2"	1/4"	60	B-38277
2-1/2"	1"	1/4"	60	B-38320
			80	B-38336
3"	1"	1/4"	60	B-38370
			80	B-38386
			120	B-38392



El equipo estándar (accesorios), las especificaciones y las fotografías pueden variar. Los accesorios pueden no estar incluidos desde origen con las herramientas aunque se indiquen en este catálogo.

Multiherramienta



Carburo de tungsteno grano, #30



Carburo de tungsteno grano, #30



Diamantado grano #40



Borde dentado



Filo de la cuchilla



Filo de la cuchilla



Base delta



Base de lijado





NUEVAS CUCHILLAS Especial para raspadura de concreto

HM disco cóncavo TMA027/ TMA028

Ambos lados de la cuchilla tienen grano de carburo de tungsteno que permite remover las rebabas de un nivel fuera de la superficie.

El borde de la hoja es curvo, no recto. Por eso, es fácil de establecer una posición que no resbale al contacto con los materiales.

En comparación con los resultados del corte fibra de vidrio, el tiempo de vida del grano de carburo de tungsteno del disco es de 10 veces más que el disco BIM.



Borde curvo

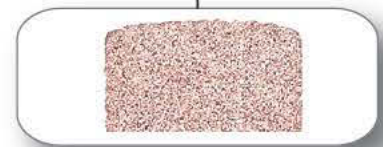

Cortando

Segmento de la cuchilla

TMA029

Profundidad de corte 25mm

Cortes limpios y rápidos en material suave

Gracias a la hoja BiM, su vida útil es más larga que la HCS



Juegos



Juego para azulejo 1



Juego para azulejo 2



Juego de piso 1



Juego de piso 2



Juego de cuchillas de penetración



Juego de carpintería

El equipo estándar (accesorios), las especificaciones y las fotografías pueden variar. Los accesorios pueden no estar incluidos desde origen con las herramientas aunque se indiquen en este catálogo.

Accesorios para multicortadora

Para modelo:

DTM51, DTM50, DTM41, DTM40, TM3010C, TM3000C

Tamaño W = ancho (mm) L= Longitud (mm)



Segmento de la cuchilla 85

TMA001



Aplicación / uso recomendado

Metales no ferrosos, FRP, PVC, adecuado para esquinas."
corte por penetración en tablaroca o paneles de fibra,
corte de molduras de longitud corta,
corta rebajes en epóxico/fibra de vidrio reforzado, plástico



Diámetro (mm)	Tipo	No. Parte
85	BiM-TiN, multi material, flat	B-21272

Segmento de la cuchilla 65

TMA002



Aplicación / uso recomendado

Metales no ferrosos, FRP, PVC
adecuado para esquinas."
cortar rebajes en epóxico/fibra de vidrio reforzado plástico
corte de hojas de metal arriba de 1mm
retiro de mastique de la ventana vieja



Diámetro (mm)	Tipo	No. Parte
65	BiM-TiN, multi material, plano	B-21288

Cuchilla redonda 85

TMA003



Aplicación / uso recomendado

Metales no ferrosos, FRP, PVC
corte en madera con clavos
cortar rebajes en epóxico/fibra de vidrio reforzado plástico
corte de molduras de longitud corta



Diámetro (mm)	Tipo	No. Parte
85	BiM-TiN, multi material, plano	B-21294

Cuchilla redonda 65

TMA004



Aplicación / uso recomendado

Metales no ferrosos, FRP, PVC
Cortar rebajes en epóxico/fibra de vidrio reforzado plástico
Corte de hojas de metal arriba de 1mm
Retiro de mastique de la ventana vieja



Diámetro (mm)	Tipo	Parte No.
65	BiM-TiN, multi material, plano	B-21303

Segmento de la cuchilla 100

TMA005



Aplicación / uso recomendado

Madera y metal, adecuado para profundidad de corte
corte del marco de la puerta a la altura del piso,
corte de parquet, piso laminado
corte de molduras de longitud corta.



Diámetro (mm)	Tipo	No. Parte
100	BiM, madera y metal, offset	B-21319

Segmento de la cuchilla 85

TMA006



Aplicación / uso recomendado

Madera y metal, adecuado para nivel de corte
corte del marco de la puerta a la altura del piso,
corte de parquet, piso laminado
corte de molduras de longitud corta.



Diámetro (mm)	Tipo	No. Parte
85	BiM, madera y metal, offset	B-21325

Segmento de la cuchilla 85

TMA007



Aplicación / uso recomendado

Madera / adecuado para nivel de corte
corte por penetración en madera sólida
corte al ras de madera
corte de tubo de plástico (PVC) a lo largo



Diámetro (mm)	Tipo	No. Parte
85	HCS, madera	B-21331

Cuchillas de corte para multiherramienta



Corte por penetración con cuchilla 32

TMA010



Aplicación / uso recomendado

Madera dura

Corte por penetración en paneles laminados o madera dura, cortar o rebajar partes de muebles, corte al ras de componentes de madera

*5 Piezas

Diámetro (mm)	Tipo	Parte No.
32 x 40	BiM, madera dura	B-21369
32 x 40	BiM, madera dura	*B-45484

Corte por penetración con cuchilla 65

TMA008



Aplicación / uso recomendado

Madera y clavos

adecuado para cortes

Corte en madera con clavos

Cortadora de marco de puerta a la altura del piso

Corte por penetración en paneles

Diámetro (mm)	Tipo	No. Parte
65 x 40	BiM, madera y clavos	B-21347

Corte por penetración con cuchilla 32

TMA012



Aplicación/ uso recomendado

Madera

Corte por penetración en madera suave, cortar o rebajar partes de muebles, Corte al ras de componentes de madera en longitud

*5 Piezas

Diámetro (mm)	Tipo	No. Parte
32 x 40	HCS, madera	B-21381
32 x 40		*B-45490

Corte por penetración con cuchilla 65

TMA041



Aplicación / uso recomendado

Diámetro (mm)	Tipo	No. Parte
65 x 40	HCS, madera	B-46850

Corte por penetración con cuchilla 10

TMA014



Aplicación/ uso recomendado

Madera

Corte por penetración en madera suave, cortar o rebajar partes de muebles, trabajos de ajuste de filigrana en madera

Diámetro (mm)	Tipo	No. Parte
10 x 30	HCS, madera	B-21406

Corte por penetración con cuchilla 28

TMA009



Aplicación/ uso recomendado

Madera y metal, adecuado para profundidad de corte en madera, corte profundo en madera, materiales abrasivos de madera, plásticos, corte de tubos y perfiles pequeños de metal no ferrosos, corte de clavos no endurecidos y perfiles de acero con dimensiones pequeñas

*5 Piezas

Diámetro (mm)	Tipo	No. Parte
28 x 50	BiM, madera y metal	B-21353
28 x 50	BiM, madera y metal	*B-45478

Corte de inmersión con cuchilla 32

TMA015



Aplicación/ uso recomendado

Metal / adecuado para corte al ras de los clavos, corte al ras de tubo de cobre, corte por penetración en tablaroca

*5 Piezas

Diámetro (mm)	Tipo	No. Parte
32 x 30	BiM, metal	B-21412
32 x 30	BiM, metal	*B-45509

El equipo estándar (accesorios), las especificaciones y las fotografías pueden variar. Los accesorios pueden no estar incluidos desde origen con las herramientas aunque se indiquen en este catálogo.

Corte por inmersión con cuchilla 20

TMA016



Aplicación / uso recomendado

Metal / adecuado para corte a ras de clavos o tubo de cobre
Corte por penetración en tablaroca

*5 Piezas

Diámetro (mm)	Tipo	No. Parte
20 x 20	BiM, metal	B-21428
20 x 20	BiM, metal	*B-45515

Corte de inmersión con cuchilla 10

TMA017



Aplicación/ uso recomendado

Metal/ adecuado para corte al ras de clavos o tablaroca,
trabajos de ajuste de filigrana en perfiles no ferrosos
corte por penetración en tablaroca

Diámetro (mm)	Tipo	No. Parte
10 x 20	BiM, metal	B-21434

HM Barra corte por penetración con cuchilla 32

TMA030



Aplicación/ uso recomendado

Metal/ adecuado para corte al ras de tornillos y clavos endurecidos
corte de acero inoxidable
corte de fibra de vidrio

Diámetro (mm)	Tipo	No. Parte
32 x 40	HM bar, metal	B-39213

Corte de inmersión con cuchilla 20

TMA031



Aplicación/ Uso recomendado

Metal / adecuado para corte al ras de los clavos y tornillos endurecidos
corte en acero inoxidable
corte en fibra de vidrio

Diámetro (mm)	Tipo	No. Parte
20 x 30	HM bar, metal	B-39229

Corte de inmersión con cuchilla en forma de arco 32

TMA032



Aplicación/ Uso recomendado

Metal / Adecuado para cortes de inmersión precisos
corte de inmersión en madera
corte de rebaje de componentes de muebles
corte de inmersión en madera suave

*5 Piezas

Diámetro (mm)	Tipo	No. Parte
32 x 40	HCS, madera	B-39235
32 x 40	BiM, madera	*B-45521

Corte de inmersión con cuchilla en forma de arco 33

TMA033



Aplicación/ uso recomendado

Madera dura / adecuado para corte de inmersión preciso
corte de inmersión en madera dura
corte de rebaje de componentes de muebles
corte de inmersión en paneles laminados

*5 Piezas

Diámetro (mm)	Tipo	No. Parte
32 x 40	BiM, madera	B-39241
32 x 40	BiM, madera	*B-45537

Corte de inmersión con cuchilla en forma de arco 33

TMA039



Aplicación / uso recomendado

Diámetro (mm)	Tipo	No. Parte
32 x 40	HCS, madera	B-46838

Corte de inmersión con cuchilla en forma de arco 34

TMA034



Aplicación / uso recomendado
madera y metal

*5 Piezas

Diámetro(mm)	Tipo	No. Parte
32 x 50	BiM, madera y metal	B-39257
32 x 50	BiM, madera y metal	*B-45543

Corte de inmersión con cuchilla 65

TMA035



Aplicación / uso recomendado
Corte de inmersión en paneles laminados o madera dura
corte al ras de componentes de madera

Diámetro (mm)	Tipo	No. Parte
65 x 40	BiM	B-40397

Corte de inmersión con cuchilla 65

TMA040



Aplicación / uso recomendado
madera

Diámetro (mm)	Tipo	No. Parte
65 x 40	HCS	B-46844

Corte de inmersión con cuchilla en forma de arco 34

TMA043



Aplicación / uso recomendado
madera y metal

Diámetro (mm)	Tipo	No. Parte
32 x 50	HCS	B-50706
32 x 50	HCS	B-50712

Cuchilla larga de inmersión en forma de arco 32

TMA037



Aplicación / uso recomendado
madera y metal

Diámetro (mm)	Tipo	No. Parte
32 x 70	BiM	B-46816

Cuchilla larga de inmersión en forma de arco 32

TMA038



Aplicación / uso recomendado
madera

Diámetro (mm)	Tipo	No. Parte
32 x 70	HSC	B-46822

Raspar



Raspador rígido 52

TMA018



Aplicación / uso recomendado
Remover mortero o adhesivo para azulejo
remover mortero o residuos de concreto
remover residuos de adhesivo para alfombra duros y frágiles

Diámetro (mm)	Tipo	No. Parte
52 x 26	HCS	B-21440

Raspador flexible 52

TMA019



Aplicación / uso recomendado
retiro de adhesivos suave de alfombra,
retiro de residuos de pintura
retiro de juntas de silicón

Diámetro (mm)	Tipo	No. Parte
52 x 45	HCS	B-21456

Corte



Cuchilla segmentada de sierra 100

TMA020



Aplicación / uso recomendado
 Poliestireno, Caucho / adecuado para material de aislamiento
 corte al ras de la longitud de sobrante de material de aislamiento, especialmente
 poliestireno corte de paneles de aislamiento al tamaño
 corte de materiales suaves (cartón, alfombra, piel, etc)

Diámetro (mm)	Tipo	No. Parte
100	BiM	B-21462

Cortador de uniones generales

TMA021



Aplicación / Uso recomendado
 Corte de uniones de expansión suaves
 Corte de mastique de la ventana
 Corte de materiales de aislamiento

Diámetro (mm)	Tipo	No. Parte
28 x 50	HCS	B-21478

Cortador de sierra

TMA036



Aplicación / uso recomendado
 madera y metal

Diámetro (mm)	Tipo	No. Parte
28 x 50	HCS	B-40406

Segmento de la cuchilla

TMA029



Aplicación/ uso recomendado
 Corte de linoleum,
 corte de alfombra,
 corte de alfombra de goma

Diámetro (mm)	Tipo	No. Parte
100	BiM, material suave	B-34827

Multicortador universal

TMA042



Aplicación / uso recomendado
 Corte de linoleum,
 corte de alfombra,
 corte de alfombra de goma

Diámetro (mm)	Tipo	No. Parte
32	HCS	B-46866

Retiro y raspado



HM Remover

TMA022



Aplicación / uso recomendado
 Retiro de uniones en azulejos en pared o piso
 retiro de mortero o adhesivo para azulejo
 retiro de uniones en pequeñas esquinas con la punta de carburo
 de tungsteno

Diámetro (mm)	Tipo	No. Parte
70	HM grit #40	B-21484

HM cuchilla cóncava 32

TMA027



Aplicación/ uso recomendado
Corte por penetración en fibra de vidrio,
quitar las rebabas del corte de fibra de vidrio,
retiro de revestimientos en esquinas o espacios estrechos

Díámetro (mm)	Tipo	No. Parte
32 x 30	HM grano#50	B-34805

HM cuchilla cóncava 20

TMA028



Aplicación/ uso recomendado
Corte por penetración en fibra de vidrio,
quitar las rebabas del corte de fibra de vidrio,
retiro de revestimientos en esquinas o espacios estrechos

Díámetro (mm)	Tipo	No. Parte
20 x 20	HM grano#50	B-34811

HM cuchilla segmentada 85

TMA023



Aplicación/ uso recomendado
Retiro de uniones en pavimentos y revestimientos cerámicos,
pequeños cortes en azulejos blandos,
ranurador en hormigón poroso, para el tendido de cables y tuberías ocultas

Díámetro (mm)	Tipo	No. Parte
85	HM grano#30	B-21490

HM cuchilla segmentada 65

TMA024



Aplicación/ uso recomendado
Ranurador en uniones extra-finas 1/16" sobre azulejos de
la pared, ranurador en epóxico / fibra de vidrio con reforzado
plástico, ranurador en hormigón poroso, para el tendido de cables
y tuberías ocultas

Díámetro (mm)	Tipo	No. Parte
65	HM grano#50	B-21509

Cuchilla segmentada de diamante



Cuchilla segmentada de diamante 85

TMA026



Aplicación/ uso recomendado
Corte de pared con revestimiento suave y FRP,
ranurado en epóxico / fibra de vidrio con reforzado plástico,
ranurado de uniones en azulejos de la pared

Díámetro (mm)	Tipo	No. Parte
85	Diamante grano#40	B-21521

Riff plato para lijado



HM base de lija 78

TMA025



Aplicación / Uso recomendado
Remueve mortero o adhesivo para azulejo
retiro de residuos de adhesivo para alfombrar
una superficie mineral.

Díámetro (mm)	Tipo	No. Parte
78	HM grit #30	B-21515

Respaldo para lijadora



Diámetro (mm)	Tipo	No. Parte
78	Convencional y velcro	B-21537
78		B-21525

Set de cuchillas para multicortador

Juego para azulejo 1

TMA016 Hoja de calar de profundidad 20
TMA023 HM Seg placa de lijado 85
TMA025 HM Placa de lijado 78

No. Parte
B-30586



Juego para azulejo 2

TMA016 hoja de calar de profundidad 20
TMA018 rascador flexible 52
TMA023 HM Seg placa de lijado 85
TMA025 HM Placa de lijado 78

No. Parte
B-30592



Juego de piso 1

TMA005 Hoja de calar segmentada 100
TMA006 Hoja de calar segmentada 8
TMA019 Rascador flexible 525

No. Parte
B-30601



Juego de piso 2

TMA006 Hoja de calar segmentada 85
TMA008 Hoja de calar de profundidad 65
TMA012 Hoja de calar de profundidad 32
TMA019 Rascador flexible 52

No. Parte
B-30617



Juego de cuchillas de penetración

TMA009 Hoja de calar de profundidad 28
TMA010 Hoja de calar de profundidad 32
TMA010 Hoja de calar de profundidad 32
TMA006 Hoja de calar segmentada 85

No. Parte
B-30623



Juego de carpintería

TMA006 Hoja de calar segmentada 85
TMA009 Hoja de calar de profundidad 28
TMA010 Hoja de calar de profundidad 32
Respaldo para lijadora x 2 piezas

No. Parte
B-30639



Multi herramientas 20 piezas



No.	Aplicación	No. Parte
TMA009	Cuchilla de penetración 28	B-34665
TMA010	Cuchilla de penetración 32	B-34659
TMA012	Cuchilla de penetración 32	B-34643
TMA018	Rascador 52 rígido	B-34671

Identificadores de materiales / adaptador para cuchillas de Dremel

Para una rápida sugerencia del accesorio



Identificador de materiales multi material

Identificador de materiales madera

Identificador de materiales madera, metal

Identificador de materiales metal

Identificador de materiales abrasivos

Adaptador para accesorios Dremel

	Descripción	Empaque piezas	No. parte
	Adaptador para accesorios Dremel	1	313249-6



El equipo estándar (accesorios), las especificaciones y las fotografías pueden variar. Los accesorios pueden no estar incluidos desde origen con las herramientas aunque se indiquen en este catálogo.



TABLA DE APLICACIONES DE LIJA PARA MULTIHERRAMIENTA

Calificación de aplicación idónea:

AA: Especialmente adecuado

A = adaptable

n.r = sin valores

		Arena	Aplicación de producto y calificación de cada material	Pintura	Bamiz	Filtro	Mezcla gruesa	Madera/materiales de madera	Madera suave	Madera dura	Enchapado	Aglomerado / MDF	Fibra de vidrio refuerzo plástico	Metal	Acero (acero dulce / acero al carbono)	Piedra	Mármol	Granito	Vidrio	Perspex	Imitación de mármol	Fibra de vidrio refuerzo plástico	
Madera / larga vida	Grueso	60																					
		80																					
	Medio	100	n.r	n.r	n.r	n.r	AA	AA	AA	AA	AA	A	AA	A	n.r	n.r	n.r	n.r	n.r	n.r	n.r	n.r	
		120																					
	Finos	180																					
	240																						
Madera	Grueso	60																					
		80																					
	Medio	100																					
		120	n.r	n.r	n.r	n.r	AA	A	AA	AA	AA	A	n.r	n.r	n.r	n.r	n.r	n.r	n.r	n.r	n.r	n.r	n.r
	Finos	150																					
	180																						
	240																						
Pintura	Grueso	60																					
		80																					
	Medio	100																					
		120	AA	AA	AA	AA	n.r	n.r	A	n.r	n.r	n.r	A	A	n.r	n.r	n.r	n.r	n.r	n.r	n.r	n.r	n.r
	Finos	240																					
	320																						
Piedra	Medio	120																					
		240																					
	Finos	400	A	AA	n.r	n.r	n.r	n.r	n.r	n.r	n.r	n.r	n.r	n.r	A	A	A	A	A	A	A	A	A
	Muy fino	600																					
	1200																						

Papel abrasivo tipo Delta

Para uso con disco de lija (B-21537) (Tipo gancho y bucle)

Madera / larga vida

Adecuado para lijar madera, madera dura, tableros de partículas, tableros de construcción y metal



Tamaño del papel (mm)	Grano	Empaque piezas	No. Parte
93	60	10	B-21565
93	80	10	B-21571
93	100	10	B-21587
93	120	10	B-21593
93	180	10	B-21602
93	240	10	B-22931
93	60,80,100,120,180	10 (2 piezas de cada uno)	B-21559

Madera



Lijar maderas y piezas de madera

Tamaño del papel (mm)	Grano	Empaque piezas	No. Parte
93	60	10	B-21624
93	80	10	B-21630
93	100	10	B-22947
93	120	10	B-21646
93	150	10	B-22953
93	180	10	B-21652
93	240	10	B-22668
93	60,80,120,180,240	10 (2 piezas de cada uno)	B-21618

Pintura



Adecuado para lijar madera y materiales hechos de madera

Tamaño del papel (mm)	Grano	Empaque piezas	No. Parte
93	60	10	B-21680
93	80	10	B-21696
93	100	10	B-21705
93	120	10	B-22969
93	240	10	B-21711
93	320	10	B-21727
93	60,80,100,240,320	10 (2 piezas de cada uno)	B-21674

Pintura



Grano	Empaque piezas	No. Parte
40	10	P-42684
60	10	P-42690
80	10	P-42709
120	10	P-42721

Piedra

Adecuado para lijar o dar brillo a metrales extremadamente duros como piedra o vidrio



Tamaño del papel (mm)	Grano	Empaque Piezas	No. Parte
93	120	10	B-21749
93	240	10	B-21755
93	400	10	B-21761
93	600	10	B-21777
93	1200	10	B-21783
93	120,240,400,600,1200	10 (2 piezas de cada uno)	B-21733

Base Delta para multicortadores y lijadoras de acabados

Modelo (BO4565, Lijadora de acabado)

Madera



Grano	Empaque piezas	No. Parte
40	10	P-33255
60	10	P-33261
80	10	P-33277
100	10	P-33283
120	10	P-33299
150	10	P-33308
180	10	P-33314
240	10	P-33320
320	10	P-33336

Lana para remover oxido



Adecuado para pulir Oxido

Tamaño del papel (mm)	Grano	Empaque piezas	No. Parte
93	280	1	B-21799
93	100	1	B-21808
93	S/G	1	B-21814

Filtro para pulir

Adecuado para pulir



Tamaño del papel (mm)	Grano	Empaque Piezas	No. Parte
93	S/G	1	B-21820

El equipo estándar (accesorios), las especificaciones y las fotografías pueden variar. Los accesorios pueden no estar incluidos desde origen con las herramientas aunque se indiquen en este catálogo.

Discos de diamante



Rosca / diámetro



Diámetro / interno



Velocidad máxima



Húmedo



Seco



No permite el desbaste por cara



DISCOS DE DIAMANTE

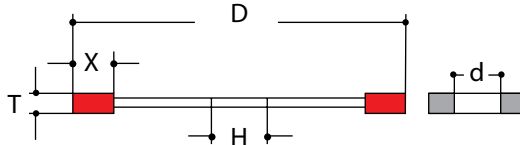

(EN) : EN13236

AA Especialmente adecuado **A** Adecuado





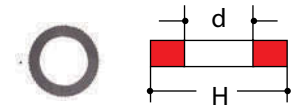







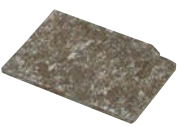





Anillo

(10 pcs./set)
(mm)

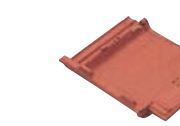

Descripción	(H) Dia. Exterior	(D) Dia. del agujero	Parte No.
Anillo 20	22.23	20	A-85248
Anillo 16	20	16	A-86860

Material

Material no. 1						
Concreto duro	Granito	Gneis	Suavizador e ingeniería	Pizarra de carbono	Vereda de pizarra	Bloque de ingeniería / Bloque de ingeniería clase 2
						
Material no. 2			Material no. 3			
Concreto	Bloque	Ranura en forma de U	Vereda en bloques	Azulejo cementado	Mármol	Sin esmaltar
						
Ladrillo	Material no. 4	Azulejo frances	Material no. 5	Material no. 6	Material no. 7	
						

COPAS DE DIAMANTE

D-60676 (4 1/2") D-60682 (5")



Aplicación en trabajos de construcción y decoración
Desbaste en PISO y PARED



Copa de diamante línea estándar

Para concreto
Uso en SECO

Para uso en miniesmeriladoras* y aplanadoras de concreto
(No. parte D-60676 se recomienda para miniesmeriladoras con tecnología SJS o de arranque suave)



(Modelos: 9564CVR / 9564PC / 9564PZ)



Ver video



* Es recomendable utilizar la cubierta para polvo por seguridad del usuario y para evitar el exceso de polvo.
No. parte 195236-5



Descripción	Grosor del segmento	Diámetro externo	Diámetro interno	Aplicación	Uso	No. parte
Copa de diamante segmentado	4x8mm	4"	7/8"	Desbaste de concreto	Seco	B-14629
Copa de diamante segmentado	4x8mm	4 1/2"	7/8"	Desbaste de concreto * Para esmeril 4 1/2"	Seco	D-60676
Copa de diamante segmentado	7x5mm	5"	7/8"	Desbaste de concreto	Seco	D-41458
Copa de diamante segmentado	5x8mm	5"	7/8"	Desbaste de concreto	Seco	B-12295
Copa de diamante segmentado	7x5mm	5"	7/8"	Desbaste de concreto Para esmeril 5"	Seco	D-60682
Copa de diamante segmentado	7x5mm	7"	7/8"	Desbaste de concreto	Seco	D-62290
Copa de diamante doble segmentado	7x5mm	4 1/2"	7/8"	Desbaste de concreto	Seco	D-62315
Copa de diamante doble segmentado	7x5mm	7"	7/8"	Desbaste de concreto	Seco	D-62321
Copa de diamante turbo	7x5mm	4 1/2"	7/8"	Desbaste de concreto	Seco	D-62343
Copa de diamante turbo	7x5mm	7"	7/8"	Desbaste de concreto	Seco	D-62359
Copa de diamante liso	13x5mm	5"	7/8"	Especial desbaste de mármol	Seco	D-41464

Desbaste

Disco diamantado angular

Seco

AA: Especialmente adecuado, A: adecuado

(EN) : EN13236



Imagen	Aplicación	D	T	X	H	d	Color	Para material							Para Modelo	No. Parte		
								1	2	3	4	5	6	7				
	Para uso general	110	13.5	4	15	-	Azul	AA	AA	AA	A	A					PC1100	A-07369(EN)
	Para acabados finos	110	13.5	4	15	-	Plata	AA	AA	AA	A	A					PC1100	792289-1(EN)
	Para acabados finos Especial p/ mármol y granito	125	13.5	4	22.23	-	Oro	AA	AA	AA	A	A					PC5000, 5001C	B-12289(EN)
	Para acabados finos	110	8	5	15	-	Plata	AA	AA	AA	A	A					PC1100	A-86321(EN)
	Para acabados finos Especial p/ mármol y granito	125	8	5	23.23	-	Oro	AA	AA	AA	A	A					PC5000, 5001C	B-12295(EN)

Línea industrial "Baja vibración"

Imagen	Descripción	Diámetro	Diámetro Interior	Grosor	Uso	Materiales a Trabajar	No. Parte
	Copa de diamante segmentado	5"	M14		Seco	Concreto, ladrillo	B-48533
	Copa de diamante doble segmentado	5"	M14		Seco	Concreto, ladrillo	B-48549
	Disco de diamante boomerang	5"	M14		Seco	Concreto, ladrillo	B-48555

Imagen	Descripción	Diámetro	Diámetro Interior	Grosor	Uso	Materiales a Trabajar	No. Parte
	Copa de diamante segmentado	5"	7/8"		Seco	Concreto, ladrillo	B-48561
	Copa de diamante doble segmentado	5"	7/8"		Seco	Concreto, ladrillo	B-48577
	Disco de diamante Boomerang	5"	7/8"		Seco	Concreto, ladrillo	B-48583

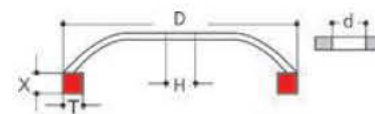
Imagen	Descripción	Diámetro	Diámetro Interior	Grosor	Uso	Materiales a Trabajar	No. Parte
	Copa de diamante segmentado	7"	M14		Seco	Concreto, ladrillo	B-48599
	Copa de diamante doble segmentado	7"	M14		Seco	Concreto, ladrillo	B-48608
	Disco de diamante Boomerang	7"	M14		Seco	Concreto, ladrillo	B-48614

Imagen	Descripción	Diámetro	Diámetro Interior	Grosor	Uso	Materiales a Trabajar	No. Parte
	Copa de diamantada turbo fino	7"	7/8"		Seco	Concreto, ladrillo	B-50005
	Copa de diamante segmentado	7"	7/8"		Seco	Concreto, ladrillo	B-48636
	Copa de diamante doble segmentado	7"	7/8"		Seco	Concreto, ladrillo	B-48642
	Disco de diamante Boomerang	7"	7/8"		Seco	Concreto, ladrillo	B-48658

El equipo estándar (accesorios), las especificaciones y las fotografías pueden variar. Los accesorios pueden no estar incluidos desde origen con las herramientas aunque se indiquen en este catálogo.

Línea económica

Esmeriladoras 4-1/2", 5", 7", 9"

	Descripción	Diámetro	Diámetro Interior	Grosor del segmento	Uso	Materiales a Trabajar	No. Parte
	Disco copa diamantada	5"	7/8"		Seco	Limpieza de linoleum y pintura	B-53160
	Disco copa diamantada	7"	7/8"		Seco	Limpieza de linoleum y pintura	B-53176

Línea profesional

	Descripción	Diámetro	Diámetro Interior	Grosor del Segmento	Uso	Materiales a Trabajar	No. Parte
	Copa de diamante liso	5"	7/8"	13x4mm	Seco	Especial para Mármol	B-12289
	Copa de diamante turbo (Baja vibración)	7"	M14		Seco	Especial para Mármol	B-48620
	Copa de diamante turbo (Baja vibración)	7"	7/8"		Seco	Especial para Mármol	B-48664

Especiales para cortadora de vidrio

	Descripción	Diámetro	Diámetro Interior	Grosor del Segmento	Uso	Materiales a Trabajar	No. Parte
	Disco de diamante segmentado Tipo dentado p/ 4190DW	3 3/8"	7/8"		Humedo	Especial para vidrio, Azulejos, Mármol y granito	A-07179
	Disco de diamante liso Rin continuo p/ 4190DW	3 3/8"	7/8"		Humedo	Especial para Azulejos, Cerámica, Mármol y vidrio	A-01323

Segmentados

Línea económica

Esmeriladoras 4-1/2", 5", 7", 9"

	Descripción	Diámetro	Diámetro Interior	Grosor del Segmento	Uso	Materiales a Trabajar	No. Parte
	Disco de diamante segmentado	4 1/2"	7/8"	1.8mm	Seco	Concreto, tabicón, cantera, ladrillo	D-44270
	Disco de diamante segmentado	7"	7/8"	2.2mm	Seco	Concreto, tabicón, cantera, ladrillo	D-44286
	Disco de diamante segmentado	9"	7/8"	2.4mm	Seco	Concreto, tabicón, cantera, ladrillo	D-44292
	Disco de diamante segmentado	4 1/2"	7/8"	1.8mm	Seco	Concreto, tabicón, cantera, ladrillo	D-44270-10
	Disco de diamante segmentado	7"	7/8"	2.2mm	Seco	Concreto, tabicón, cantera, ladrillo	D-44286-10
	Disco de diamante segmentado	9"	7/8"	2.4mm	Seco	Concreto, tabicón, cantera, ladrillo	D-44292-10
	Disco de diamante segmentado	4 1/8"	7/8"		Seco-humedo	Concreto, tabicón, cantera, ladrillo	D-05197-10
	Disco de diamante segmentado	7"	7/8"	2.4mm	Seco	Concreto, tabicón, cantera, ladrillo	D-37574-10

Línea estándar "Long life"

Esmeriladoras 4-1/2", 5", 7", 9"

	Descripción	Diámetro	Diámetro Interior	Grosor del Segmento	Uso	Materiales a Trabajar	No. Parte
	Disco de diamante segmentado	4-1/2"	7/8"	2mm	Seco	Concreto, tabicón, cantera, ladrillo	D-37552
	Disco de diamante segmentado	5"	7/8"	2.2mm	Seco	Concreto, tabicón, cantera, ladrillo	D-37568
	Disco de diamante segmentado	7"	7/8"	2.4mm	Seco	Concreto, tabicón, cantera, ladrillo	D-37574
	Disco de diamante segmentado	9"	7/8"	2.6mm	Seco	Concreto, tabicón, cantera, ladrillo	D-37580

Línea profesional

Esmeriladoras 4-1/2", 5", 7", 9"

	Descripción	Diámetro	Diámetro interior	Grosor del Segmento	Uso	Materiales a Trabajar	No. Parte
	Disco de diamante segmentado	4-1/2"	7/8"	1.9mm	Seco	Concreto, tabicón, cantera, ladrillo, asfalto	A-84109
	Disco de diamante segmentado	5"	7/8"	1.9mm	Seco	Concreto, tabicón, cantera, ladrillo, asfalto	A-84115
	Disco de diamante segmentado	7"	7/8"	2.3mm	Seco	Concreto, tabicón, cantera, ladrillo, asfalto	A-84121
	Disco de diamante segmentado	9"	7/8"	2.5mm	Seco	Concreto, tabicón, cantera, ladrillo, asfalto	A-84137

Línea industrial "láser"

Esmeriladoras 4-1/2", 5", 7", 9"

	Descripción	Diámetro	Diámetro interior	Grosor del Segmento	Uso	Materiales a Trabajar	No. Parte
	Disco de diamante segmentado	4-1/2"	7/8"	2.2mm	Seco	Concreto, concreto duro, tabicón, cantera, ladrillo, asfalto	D-44389
	Disco de diamante segmentado	5"	7/8"	2.2mm	Seco	Concreto, concreto duro, tabicón, cantera, ladrillo, asfalto	D-44395
	Disco de diamante segmentado	7"	7/8"	2.2mm	Seco	Concreto, concreto duro, tabicón, cantera, ladrillo, asfalto	D-44404
	Disco de diamante segmentado	9"	7/8"	2.4mm	Seco	Concreto, concreto duro, tabicón, cantera, ladrillo, asfalto	D-44410

Cortadora de concreto a gasolina

Línea económica

	Descripción	Diámetro	Diámetro interior	Grosor del Segmento	Uso	Materiales a Trabajar	No. Parte
	Disco de diamante segmentado	12"	1"	3mm	Seco	Concreto, tabicón, cantera, ladrillo	D-56982
	Disco de diamante segmentado	14"	1"	4mm	Seco	Concreto, tabicón, cantera, ladrillo	D-56998
	Disco de diamante segmentado	16"	1"	4mm	Seco	Concreto, tabicón, cantera, ladrillo	D-57009

Cortadora de concreto a gasolina

Línea estándar

	Descripción	Diámetro	Diámetro interior	Grosor del Segmento	Uso	Materiales a Trabajar	No. Parte
	Disco de diamante segmentado	12"	1" Red (20mm)	3mm	Humedo	Concreto, tabicón, cantera, ladrillo	A-94720
	Disco de diamante segmentado	14"	1" Red (20mm)	4mm	Humedo	Concreto, tabicón, cantera, ladrillo	A-94736

Línea industrial

(Quasar)

	Descripción	Diámetro	Diámetro interior	Grosor del Segmento	Uso	Materiales a Trabajar	No. Parte
	Disco de diamante segmentado corte metal	12"	20mm	3mm	Humedo seco	Concreto, cantera, ladrillo	B-13459
	Disco de diamante segmentado corte metal	14"	1"	3mm	Humedo seco	Concreto, cantera, ladrillo	B-13465
	Disco de diamante segmentado corte metal	16"	1"	3mm	Humedo seco	Concreto, cantera, ladrillo	B-13471

El equipo estándar (accesorios), las especificaciones y las fotografías pueden variar. Los accesorios pueden no estar incluidos desde origen con las herramientas aunque se indiquen en este catálogo.

2414NB/MLC141

Línea profesional

	Descripción	Diámetro	Diámetro interior	Grosor del Segmento	Uso	Materiales a Trabajar	No. Parte
	Disco de diamante segmentado corte metal	14"	1"	3mm	Seco	Metal, varilla, tubular, perfil, ángulo	D-41414
	Disco de diamante segmentado corte metal "Fast Cut"	14"	1"	3mm	Seco	Metal, varilla, tubular, perfil, ángulo	B-29511

Rin Continuo

Línea económica concavos, cortes curvos

Especial para "4100-4102NH,-4100NS



*Con reductor a 5/8"

	Descripción	Diámetro	Diámetro interior	Grosor del Segmento	Uso	Materiales a Trabajar	No. Parte
	Disco de diamante turbo concavo	4-3/8"	20mm	25mm	Seco	Mármol, tabicón, concreto, adoquín	D-36968

Línea económica

Especial para "4100-4102NH,-4100NS

*Con reductor a 5/8"

	Descripción	Diámetro	Diámetro interior	Grosor del Segmento	Uso	Materiales a Trabajar	No. Parte
	Disco de diamante rin continuo p/ azulejo	4-3/8"	20mm	2mm	Humedo	Especial para azulejo	D-44258
	Disco de diamante rin continuo	4"	20mm	2mm	Humedo	Concreto, tabique, mármol, azulejo	D-05212

Disco de carburo de tungsteno

	Descripción	Diámetro	Diámetro interior	Grosor del Segmento	Uso	Materiales a Trabajar	No. Parte
	Grano carburo de tungsteno	4-1/2"	22.23mm		Seco	Placa de yeso, PVC, material FRP	B-57716
	Grano carburo de tungsteno	9"	22.23mm		Seco	Placa de yeso, PVC, material FRP	B-57722

Línea económica

Especial para "4100-4102NH,-4100NS

*Con reductor a 5/8"

	Descripción	Diámetro	Diámetro interior	Grosor del Segmento	Uso	Materiales a Trabajar	No. Parte
	Disco de diamante segmentado	4"	20mm	2mm	Seco	Especial para concreto	D-42531

Línea estándar

Herramientas estacionarias

	Descripción	Diámetro	Diámetro interior	Grosor del Segmento	Uso	Materiales a Trabajar	No. Parte
	Disco de diamante liso	7"	1"	2.2mm	Humedo	Mármol, azulejo	D-41436
	Disco de diamante liso	8"	1"	2.2mm	Humedo	Mármol, azulejo	D-41442

Línea económica TURBO

Especial para *4100-4102NH,-4100NS

*Con reductor a 5/8"

	Descripción	Diámetro	Diámetro interior	Grosor del Segmento	Uso	Materiales a Trabajar	No. Parte
	Disco de diamante turbo	4"	20mm	2mm	Seco	Especial para granito, mármol	D-42553

Línea profesional

Especial para *4100-4102NH-4100NS

	Descripción	Diámetro	Diámetro interior	Grosor del Segmento	Uso	Materiales a Trabajar	No. Parte
	Disco de diamante rin continuo, especial para porcelana	4-3/8"	20mm	1.8mm	Humedo	Especial para porcelana	B-22925

Línea profesional

Especial para *4100-4102NH-4100NS

*Con reductor a 5/8"

	Descripción	Diámetro	Diámetro interior	Grosor del Segmento	Uso	Materiales a Trabajar	No. Parte
	Disco de diamante rin continuo especial para mármol electrodepositado	4-3/8"	20mm	2mm	Humedo	Especial para mármol (diamante electrodepositado)	D-38277

Línea profesional

Especial para *4100-4102NH-4100NS

*Con reductor a 5/8"

	Descripción	Diámetro	Diámetro interior	Grosor del Segmento	Uso	Materiales a Trabajar	No. Parte
	Disco de diamante rin continuo especial para vidrio	4-3/8"	20mm	1.2mm	Humedo	Especial para vidrio	D-40705

El equipo estándar (accesorios), las especificaciones y las fotografías pueden variar. Los accesorios pueden no estar incluidos desde origen con las herramientas aunque se indiquen en este catálogo.

Línea profesional

Especial para "4100-4102NH-4100NS

	Descripción	Diámetro	Diámetro interior	Grosor del Segmento	Uso	Materiales a Trabajar	No. Parte
	Disco de diamante rim continuo especial para concreto, granito	4-3/8"	20mm	2mm	Humedo	Especial para mármol	D-45004

Línea profesional

Especial para "4100-4102NH,-4100NS

	Descripción	Diámetro	Diámetro interior	Grosor del Segmento	Uso	Materiales a Trabajar	No. Parte
	Disco de diamante segmentado para concreto	5"	20mm	2mm	Seco	Especial para concreto, "Long Life"	D-38261

Línea económica TURBO / SEGMENTADO

Especial para "4100-4102NH-4100NS

*Con reductor a 5/8"

	Descripción	Diámetro	Diámetro interior	Grosor del Segmento	Uso	Materiales a Trabajar	No. Parte
	Disco de diamante turbo-segmentado	4"	20mm	2mm	Seco	Especial para concreto, granito	D-42581

Línea estándar concavos, cortes curvos

Especial para "4100-4102NH-4100NS

	Descripción	Diámetro	Diámetro interior	Grosor del Segmento	Uso	Materiales a Trabajar	No. Parte
	Disco de diamante segmentado concavo	4-3/8"	20mm	2.5mm	Humedo	Azulejo, mármol, adoquín, granito	D-30623
	Disco de diamante turbo concavo	4-3/8"	20mm	2.5mm	Humedo	Azulejo, mármol, adoquín, granito	D-30639

Línea profesional

Especial para "4100-4102NH,-4100NS

	Descripción	Diámetro	Diámetro interior	Grosor del Segmento	Uso	Materiales a Trabajar	No. Parte
	Disco de diamante turbo para concreto, granito	5"	20mm	2.6mm	Humedo	Especial para concreto, granito	B-16748

Lisos

Línea económica

Usos especiales

	Descripción	Diámetro	Diámetro interior	Grosor del Segmento	Uso	Materiales a Trabajar	No. Parte
	Disco de diamante liso	4-1/2"	7/8"	17mm	Seco	Azulejo, mármol, granito	D-36837

Línea industrial diamante electrodepositado

Esmeriladoras 4-1/2", 7"

	Descripción	Diámetro	Diámetro interior	Grosor del Segmento	Uso	Materiales a Trabajar	No. Parte
	Disco de diamante liso	4-1/2"	7/8"	1.3mm	Seco	Granito, asfalto	D-51085
	Disco de diamante liso	7"	7/8"	1.6mm	Seco	Granito, asfalto	D-51091
	Disco de diamante liso	9"	7/8"	1.3mm	Seco	Granito, asfalto	D-51100

Línea multimateriales

	Descripción	Diámetro	Diámetro interior	Grosor del Segmento	Uso	Materiales a Trabajar	No. Parte
	Disco de diamante segmentado multimateriales	4-1/2"	7/8"	1.8mm	Seco	Concreto, metal, PVC	D-58883
	Disco de diamante segmentado multimateriales	7"	7/8"	1.8mm	Seco	Concreto, metal, PVC	D-58899
	Disco de diamante segmentado multimateriales	9"	7/8"	2.0mm	Seco	Concreto, metal, PVC	D-58908

Línea industrial diamante electrodepositado

	Descripción	Diámetro	Diámetro interior	Grosor del Segmento	Uso	Materiales a Trabajar	No. Parte
	Disco de diamante liso	4-1/2"	7/8"	1.3mm	Seco	Concreto, tubo PVC, metal no ferroso, inox	B-53687
	Disco de diamante liso	7"	7/8"	1.6mm	Seco	Concreto, tubo PVC, metal no ferroso, inox	B-53702
	Disco de diamante liso	9"	7/8"	1.6mm	Seco	Concreto, tubo PVC, metal no ferroso, inox	B-53718

Turbo

Línea económica

Esmeriladoras 4-1/2", 5", 7", 9"

	Descripción	Diámetro	Diámetro interior	Grosor del Segmento	Uso	Materiales a Trabajar	No. Parte
	Disco de diamante turbo	4-1/2"	7/8"	1.8mm	Seco	Concreto, mármol, azulejo	D-44301
	Disco de diamante turbo	7"	7/8"	2.2mm	Seco	Concreto, mármol, azulejo	D-44317
	Disco de diamante turbo	9"	7/8"	2.4mm	Seco	Concreto, mármol, azulejo	D-44323

El equipo estándar (accesorios), las especificaciones y las fotografías pueden variar. Los accesorios pueden no estar incluidos desde origen con las herramientas aunque se indiquen en este catálogo.

Línea estándar "Long life"

Esmeriladoras 4-1/2", 5", 7", 9"

	Descripción	Diámetro	Diámetro interior	Grosor del Segmento	Uso	Materiales a Trabajar	No. Parte
	Disco de diamante turbo	4-1/2"	7/8"	2mm	Seco	Concreto, mármol, azulejo	D-37596
	Disco de diamante turbo	5"	7/8"	2.2mm	Seco	Concreto, mármol, azulejo	D-37605
	Disco de diamante turbo	7"	7/8"	2.4mm	Seco	Concreto, mármol, azulejo	D-37611
	Disco de diamante turbo	9"	7/8"	2.6mm	Seco	Concreto, mármol, azulejo	D-37627

Línea estándar

Herramientas estacionarias

	Descripción	Diámetro	Diámetro interior	Grosor del Segmento	Uso	Materiales a Trabajar	No. Parte
	Disco de diamante liso	7"	1"	2mm	Humedo	azulejo	D-44264

Línea profesional

Esmeriladoras 4-1/2", 5", 7", 9"

	Descripción	Diámetro	Diámetro interior	Grosor del Segmento	Uso	Materiales a Trabajar	No. Parte
	Disco de diamante turbo	4-1/2"	7/8"	2mm	Seco	Concreto	A-84143
	Disco de diamante turbo	4-1/2"	7/8"	2.3mm	Seco	Granito, asfalto	A-84056
	Disco de diamante turbo	5"	7/8"	2.1mm	Seco	Concreto	A-84159
	Disco de diamante turbo	7"	1"	2.3mm	Seco	Concreto	A-84165
	Disco de diamante turbo	9"	7/8"	2.6mm	Seco	Concreto	A-84171
	Disco de diamante turbo	4-1/2"	7/8"	1.4mm	Humedo / seco	Porcelana, cerámica	B-46327
	Disco de diamante turbo	5"	7/8"	1.4mm	Humedo / seco	Porcelana, cerámica	B-46333

Línea industrial "ultra delgado"

Esmeriladoras 4-1/2", 7"

	Descripción	Diámetro	Diámetro interior	Grosor del Segmento	Uso	Materiales a Trabajar	No. Parte
	Disco de diamante turbo	4-1/2"	7/8"	1.3mm	Seco	Porcelana	D-50893
	Disco de diamante turbo	7"	7/8"	1.6mm	Seco	Porcelana	D-50902

Línea de rescate

Esmeriladoras 4-1/2", 7"

	Descripción	Diámetro	Diámetro interior	Grosor del Segmento	Uso	Materiales a Trabajar	No. Parte
	Disco de diamante electrodepositado	4-1/2"			Seco	Multimaterial	B-55304
	Disco de diamante electrodepositado	9"			Seco	Multimaterial	B-55326
	Disco de diamante electrodepositado	14"			Seco	Multimaterial	B-55348

Disco pulidor diamantado de 100mm

(tipo gancho y bucle)

Para modelo:
PW5000C, PW5001C



Color	Arena	No. Parte
Azul	50	D-15584
Amarillo	100	D-15590
Naranja	200	D-15609
Rojo	400	D-15615
Verde obscuro	800	D-15621
Verde claro	1500	D-15637
Café	3000	D-15643
Verde	Pulir (acabado)	D-15659

Base metálica inclinada

Usar en	Tipo	No. Parte
4100NH2R	Base metálica inclinada tipo rodillo	Base 4100NH2R
4100NH2V	Base metálica inclinada trabajo en húmedo	Base 4100NH2V

Barrenos en concreto para toma de muestras de fraguado

Coronas de diamante para concreto
brocas saca corazones



Brocas de diamante electrodepositado

Para porcelanato

Ideales para perforar desde
azulejo hasta porcelanato

Lubricado con aceite



Perforación sin percusión

Ver video



Díámetro	No. Parte
6mm (1/2")	B-51823
8mm (5/16")	B-51839
10mm (3/8")	B-51845



Díámetro (mm)	Longitud total	Empaque Piezas	No. Parte
29	250	1	A-11645
40	250	1	A-11667
52	250	1	A-11673
65	250	1	A-11689
75	250	1	A-11704
80	250	1	A-11710
90	250	1	A-11726
100	250	1	A-11732
115	250	1	A-11748
120	250	1	A-11760
Extensión p/ Coronas	200	1	A-11807

Brocasieras de diamante electrodepositado

Para mármol



Ver video



Perforación sobre placas de mármol para usar con esmeril angular de 4-1/2", 7", 9"

Material: mármol

Díámetro	Rosca de la cabeza	No. Parte
1/2"	5/8"-11	*D-37758
1-1/4"	5/8"-11	*D-36332
1-3/8"	5/8"-11	*D-36348
2"	5/8"-11	*D-37764

Reductores



Descripción	Medidas	Empaque piezas	No. Parte
Reductor	25.4mm-22.23mm (espesor:1.6mm)	1	D-50871
Reductor	25.4mm-22.23mm (espesor:1.8mm)	1	D-50887

El equipo estándar (accesorios), las especificaciones y las fotografías pueden variar. Los accesorios pueden no estar incluidos desde origen con las herramientas aunque se indiquen en este catálogo.

Accesorios para cortadora de mármol

Mangueras de alimentación



Aplicación	Diámetro	Longitud Total	Empaque piezas	No. Parte
Manguera transparente para alimentación de agua cortadoras 4100NHK/ NSX,MT410	5mm. Int. X 7mm. Ext	5 metros	1	412010-9
Manguera transparente para alimentación de agua cortadoras 4100NHK/ NSX,MT410	5mm. Int. X 9mm. Ext	5 metros	1	412028-0
Manguera transparente para alimentación de agua cortadoras 4100NHK/ NSX,MT410	5mm. Int. X 7mm. Ext	5 metros	1	412088-2

Dispositivos de refrigeración



Descripción	Empaque piezas	No. Parte
Depósito de agua con colector p/ 4190D, 5090D	1	122387-1
Depósito de agua con colector p/ 4190D, 5090D	1	134152-6
Conector de suministro p/ MT410,MCC400	1	418558-9

LÍNEA DE RESCATE

Accesorios para utilizar con herramienta inalámbrica, sierra sable, miniesmeril o cortadora a gasolina y motosierras en **LABORES DE RESCATE**

DISCO DE DIAMANTE ELECTRODEPOSITADO

Capaz de cortar diversos materiales como metal, concreto, resina y vidrio templado (MULTIMATERIAL)

Descripción	Piezas empaque	No. parte
Disco de diamante Electrodepositado 4 1/2" Multi P/Rescate	1	B-55304
Disco de diamante Electrodepositado 9" Multi P/Rescate	1	B-55326
Disco de diamante Electrodepositado 14" Multi P/Rescate	1	B-55348

Granulado del disco soldado directamente sobre la base del disco



CADENAS Y ESPADAS para motosierras

Capaz de cortar puertas de coche, materiales compuestos o madera con clavos, concreto aireado y resinas



Diente de Carburo de Tungsteno

Descripción	Diente	Material	Piezas empaque	No. parte
Kit de rescate: Cadena 380mm, barra y limitador		para metal	1	957415030
Cadena de rescate 380mm	TCT	para metal	1	957696056
Barra guía de rescate 380mm			1	415038751
Kit de rescate: Cadena 450mm, barra y limitador		para metal	1	957415040
Cadena de rescate 380mm	TCT	para metal	1	957696064
Barra guía de rescate 380mm			1	415045751
Kit de rescate: Cadena 430mm, barra y limitador		para metal	1	957415060
Barra guía de rescate 430mm			1	465043755
Tope de profundidad para usar c/ barra guía 415045751			1	957250100

Fresas para router



Pinza sujetadora para tabla yeso

A: pedazo de diamante

Para modelo: 3706



Porte	Tipo	Parte No.
3.18mm(1/8")	-	733229-0
6.35mm(1/4")	-	733232-1

Adaptador para guía copiadora 30

(Plantillas para B y D, cable de dos piezas)

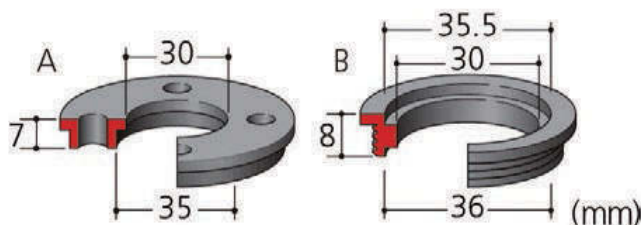

Tuerca M30, No. Parte 252627-4

Plantilla adaptador 30, tipo A o tipo B

Plantilla 25, No. Parte 321812-1



Depósito de guía

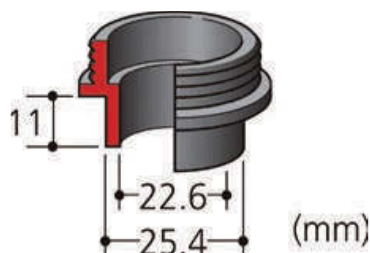

* Usar con el conjunto de base de ensamblaje

Modelo No.	Parte No.
3612BR	122256-6
RP1800/F, RP1801/F, RP2300FC, RP2301FC	122700-3

Modelo No.	Tipo	Parte No.
3612BR, RP0900, RP1800/F, RP1801/F, RP2300FC, RP2301FC, *RT0700C	A	321492-3



Guía copiadora

Para modelo:

3612BR, RP0900, RP1800/F, RP1801/F, RP2300FC, RP2301FC, *RT0700C

*Usar con el conjunto de base de ensamblaje

A(mm)	B(mm)	C(mm)	Tipo	No. Parte
7.7	9.5	11.5	-	164379-4
9	11	13	-	164775-6
11	12.7	13	-	164776-4
14.5	16	13	-	344364-5
18	20	13	-	164393-0
24	27	13	-	164470-8

Para modelo:
3600H, 3601B

A(mm)	B(mm)	C(mm)	Tipo	No. Parte
11.1	12.7	14.3	-	321472-9
14	16	8	-	323018-7
14	16	14.5	-	321308-2

Para modelo:

RF1100, RF1101, RD1100, RD1101, RP1100, RP1101

A"	B"	C"	Tipo	No. Parte
57/64"	1"	7/16"	A	193235-1
21/32"	3/4"	9/16"	A	193261-0
11/32"	7/16"	5/32"	A	193262-8
13/32"	1/2"	5/16"	A	193263-6
9/32"	3/8"	5/16"	A	193264-4
5/8"	54/64"	9/16"	A	193265-2
17/32"	5/8"	9/16"	A	193266-0
17/32"	5/8"	7/32"	A	193366-6

Guía de corte al hilo

Usar con el conjunto de base de ensamblaje



Modelo No.	No. Parte
3600H, 3601B	122343-1
3612BR, RP1800/F, RP1801/F, RP2300FC, RP2301FC	123022-4
RP0900, *RT0700C	STEX122385

Guía recta

A: Guía recta con micro ajuste



* Usar con el conjunto de base de ensamblaje

Modelo No.	Tipo	Material	No. Parte
3600H, 3601B	-		123029-0
3612BR	-		342428-9
RP0900, RP0910, RP1110C	-		164834-6
RF1100, RF1101, RD1100, RD1101, RP1100, RP1101	-		193073-1

Set de adaptadores para carriles de guía

1 Set de adaptación de rieles



2 Riel de guía



3 Set de abrazadera



*Usar con el conjunto de base de ensamblaje

Tipo	Para Modelo	No. Parte
1	3612BR, RP0900, RP0910, RP1110C, RP1800/F, RP1801/F, RP2300FC, RP2302FC, *RT0700C	194579-2
2	Guía riel 1.4m para SP6000	194368-5
	Guía riel 3.1m para SP6000	194367-7
3	Conjunto abrazadera	194385-5

El equipo estándar (accesorios), las especificaciones y las fotografías pueden variar. Los accesorios pueden no estar incluidos desde origen con las herramientas aunque se indiquen en este catálogo.

Base transparente

A: Base transparente / B: Para biselado / C: Para un ajuste profundo



Modelo No.	Tipo	No. Parte
3700B, N3701, 3703, 3704	B	STEX122390
DRT50	A	199090-9

Guía recta



Modelo No.	Tipo	No. Parte
3706	B	123058-3

Guía circular



Modelo No.	Tipo	No. Parte
3706	B	193448-4

Guía paralela



Modelo No.	Tipo	No. Parte
3612/C, RP1800, RP3200FC		194935-6

Guía copiadora

(Use plantillas para una producción más rápida de formas complejas)

A(mm)	B(mm)	C(mm)	Tipo	Parte No.
8	10	9.5	-	343577-5

Para modelo:

3707/F/FC, 3708/F/FC, 3709, 3710, N3701, RT0700C

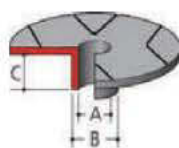

Montaje de la base de la banda del router



Modelo No.	Parte No.
N3701, 4402, 4403	JPA122201

Collets y tuercas de sujeción



Usar en	Descripción	Medida	No. Parte
GD0800C, GD0810C	Collet con tuerca	1/8"	192987-1
RF1100, RF1101, RD1100, RD1101, RP1100, RP1101	Collet con tuerca	1/4"	193214-9
RF1100	Collet con tuerca	1/2"	193215-7
3606	Collet	3mm	763610-1
903	Collet	1/4"	763608-8
906/H, GD0600, GD0601	Collet	6mm	763620-8
3601B, 3620, RP0900, RT0700C	Collet	1/4"	763637-1
3709, 3710	Collet	1/4"	763663-0
RP0900	Collet	3/8"	763619-3
RP1101, RD1101, RF1101, RP1101	Collet	1/2"	763643-6
3600H, 3612BR, RP1800/F, RP1801/F, RP2300FC, RP2301FC	Collet	1/2"	763622-4
3601B, 3620	Tuerca de sujeción	1/2"	763623-2
GE0600	Tuerca de sujeción	1/4"	763625-8
906H	Tuerca de sujeción	1/8"	763626-6
903	Tuerca de sujeción	3mm	763609-6
3709, 3707	Tuerca de sujeción	6.5mm	763661-4
GD0600	Tuerca de sujeción	6mm	763664-8
3706, 3707	Tuerca de sujeción	8mm	763606-2
GD0800C, GD0810C	Tuerca de sujeción	10mm	763645-2
RP1801, RP2301, 3612	Tuerca de sujeción	1/2"	763629-0
RF1100	Tuerca de sujeción	1/2"	763642-8
GD0602, BGD800	Tuerca de sujeción	1/4"	763668-0
RP2300, RP1800	Tuerca de sujeción	1/2", 1/4"	763674-5
3600H, 3601B, 3612BR, RP1800/F, RP1801/F, RP2300FC, RP2301FC	Buje reductor	1/2", 1/4"	763803-0
3600H, 3601B, 3612BR, RP1800/F, RP1801/F, RP2300FC, RP2301FC	Buje reductor	1/2", 3/8"	763805-6
GD0800	Collet	1/4"	193143-6
GD0800	Collet	6mm	193012-0

Bases para routers



Usar en	Descripción	Empaque Piezas	No. Parte
3606,3612,3621	Cabezal para aspiradora	1	192035-6
RD1101	Boquilla para bolsa de polvo	1	193379-7
RD1100	Base estándar	1	193103-8
RD1101	Base de mango, base con empuñadura	1	193104-6
RP1101	Sub base (acrílico)	1	193155-9
RT0700CX2	Base recortadora	1	196094-2
RT0700CX2	Base recortadora	1	196092-6
RT0700CX2	Base recortadora	1	196093-4

Otros



Usar en	Descripción	Empaque Piezas	No. Parte
3706	Depósito de la llave	1	423319-4

Galletas para ensamble



Usar en	Aplicación	Medidas	Empaque Piezas	No. Parte
Engalletadoras mod. 3901, PJ7000, LXPJ02	Ensamble de piezas de madera	# 0	Bolsa 1000 pzs.	P-08838
Engalletadoras mod. 3901, PJ7000, LXPJ02	Ensamble de piezas de madera	# 10	Bolsa 1000 pzs.	P-08844
Engalletadoras mod. 3901, PJ7000, LXPJ02	Ensamble de piezas de madera	# 20	Bolsa 1000 pzs.	P-08850

Disco para engalletadora

Ranurado de piezas de madera para ensamble



Diámetro	Dientes	Descripción	Empaque Piezas	No. Parte
4x7/8"	6	Disco de sierra para engalletadora	1	A-94982

Complementos



Descripción	Aplicación	Empaque Piezas	No. Parte
Empuñadura superior	Mejor control y apoyo	1	415253-2
Guía regla	Ajuste para cortes exactos	1	122473-8

Fresas para router "estándar" Cola de milano

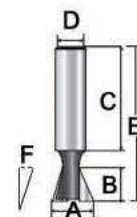

A	B	C	D	E	F	Empaque Piezas	No. Parte
3/8"	3/8"	1-1/4"	1/4"	1-3/4"	9°	1	D-01878
3/8"	3/8"	1-1/2"	1/2"	2-3/16"	9°	1	D-01884
1/2"	1/2"	1-1/4"	1/4"	1-7/8"	14°	1	D-01909
5/8"	7/8"	1-7/16"	1/2"	2-33/64"	7°	1	D-01915
1/4"	3/8"	1-61/64"	1/4"	2-1/2"	7.5°	1	D-01937
5/16"	3/8"	1-11/16"	1/4"	2-7/32"	9°	1	D-01943

Fresas para abertura de canal recto

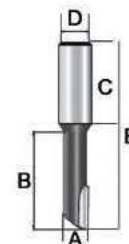

A	B	C	D	E	Empaque Piezas	No. Parte
3/8"	1-1/2"	1-1/4"	1/2"	3"	1	D-01965

Fresas para bisagras

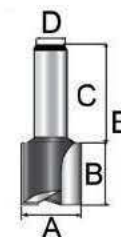

A	B	C	D	E	Empaque piezas	No. Parte
1/2"	3/4"	1-1/4"	1/4"	2-1/64"	1	D-01644
3/4"	3/4"	1-1/4"	1/4"	2-1/64"	1	D-01650

El equipo estándar (accesorios), las especificaciones y las fotografías pueden variar. Los accesorios pueden no estar incluidos desde origen con las herramientas aunque se indiquen en este catálogo.

Fresa recta

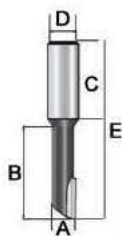

A	B	C	D	E	Empaque Piezas	No. Parte
1/8"	7/16"	1-3/8"	1/4"	2-3/32"	1	D-01270
1/8"	13/64"	1-3/8"	1/4"	1-27/32"	1	D-01345
3/16"	7/16"	1-3/8"	1/4"	2"	1	D-01367
1/4"	1"	1-1/4"	1/4"	2-3/8"	1	D-01286
1/4"	3/4"	1-1/4"	1/4"	2-1/8"	1	D-01373
1/4"	1"	1-1/4"	1/4"	2-3/8"	1	D-01389
1/4"	3/4"	1-1/2"	1/2"	2-9/16"	1	D-01507
5/16"	1"	1-1/4"	1/4"	2-17/64"	1	D-01395
3/8"	1"	1-1/2"	1/2"	2-3/4"	1	D-01292
3/8"	1"	1-1/4"	1/4"	2-17/64"	1	D-01404
3/8"	1"	1-1/2"	1/2"	2-47/64"	1	D-01513
7/16"	1"	1-1/4"	1/4"	2-17/64"	1	D-01410
1/2"	1-1/4"	1-3/8"	1/2"	2-7/8"	1	D-01301
1/2"	1-1/2"	1-3/8"	1/2"	3-1/8"	1	D-01317
1/2"	2"	2-1/16"	1/2"	4-1/4"	1	D-01323
1/2"	1"	1-1/4"	1/4"	2-17/64"	1	D-01426
1/2"	1"	1-1/2"	1/2"	2-21/32"	1	D-01529
5/8"	3/4"	1-1/4"	1/4"	2-1/64"	1	D-01432
3/4"	3/4"	1-1/4"	1/4"	2-1/64"	1	D-01448
1"	1-1/4"	*	1/2"	*	1	D-01622
1-1/4"	1-1/4"	1-1/2"	1/2"	2-3/4"	1	D-01638

Fresas tipo U

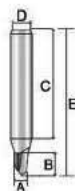

A	B	C	D	E	Empaque Piezas	No. Parte
1/8"	7/32"	1-9/64"	1/4"	1-37/64"	1	D-01672
3/16"	7/32"	1-3/16"	1/4"	1-37/64"	1	D-01688

Ranuras tipo "v"

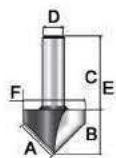

A	B	C	D	E	F	Empaque piezas	No. Parte
3/8"	7/64"	1-3/16"	1/4"	1-5/8"	3/8"	1	D-01828
5/8"	5/8"	1-1/4"	1/4"	1-57/64"	7/8"	1	D-01840

Fresa media caña

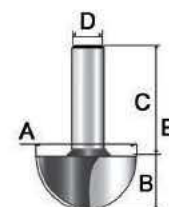

A	B	C	D	E	Empaque Piezas	No. Parte
1/4"	1/4"	1-1/4"	1/4"	1-5/8"	1	D-01719
3/8"	1/4"	1-1/4"	1/4"	1-33/64"	1	D-01725
1/2"	3/8"	1-1/4"	1/4"	1-41/64"	1	D-01731
5/8"	7/16"	1-5/16"	1/4"	1-3/4"	1	D-01747
3/4"	7/16"	1-5/16"	1/4"	1-3/4"	1	D-01753
1"	11/16"	1-7/16"	1/2"	2-1/8"	1	D-01775
1-1/4"	3/4"	1-1/4"	1/2"	5/16"	1	D-01781

Fresas piloto HT



A	B	C	D	E	Empaque Piezas	No. Parte
1/4"	3/4"	1"	1/4"	2-9/16"	1	D-01987

Fresas recta con balero superior 2 canales

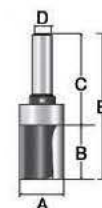

A	B	C	D	E	Empaque Piezas	No. Parte
1/2"	1"	1-1/2"	1/4"	2-1/2"	1	D-02054
3/4"	1"	1-1/2"	1/4"	2-1/2"	1	D-02076

Fresas "V" media caña HT

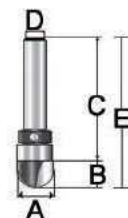

A	B	C	D	E	Empaque piezas	No. Parte
1/2"	3/8"	1-1/2"	1/4"	1-7/8"	1	D-02107

ACCESORIOS

Fresas para router

Fresas para cerraduras



A	B	C	D	E	Empaque piezas	No. Parte
3/8"	3/8"	1"	1/4"	1-1/2"	1	D-02129

Esquina redondeada

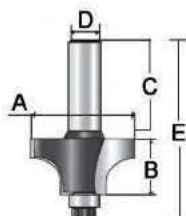

A	B	C	D	E	F	Empaque piezas	No. Parte
1/8"	3/8"	1-1/4"	1/4"	2-1/16"	3/4"	1	D-02141
3/16"	1/2"	1-1/4"	1/4"	2-3/16"	7/8"	1	D-02163
1/4"	1/2"	1-1/4"	1/4"	2-3/16"	1"	1	D-02185
1/4"	1/2"	1-1/2"	1/2"	2-7/16"	1"	1	D-02191
3/8"	5/8"	1-1/4"	1/4"	2-5/16"	1-1/4"	1	D-02216
1/2"	3/4"	1-1/2"	1/2"	2-11/16"	1-1/2"	1	D-02244
5/8"	7/8"	1-5/16"	1/2"	2-3/8"	1-3/4"	1	D-02250
3/4"	1"	1-5/16"	1/2"	2-3/8"	2"	1	D-02266

Moldura

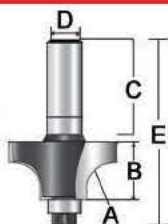

A	B	C	D	E	F	Empaque piezas	No. Parte
3/16"	1/2"	1-1/4"	1/4"	2-7/64"	7/8"	1	D-02319
1/4"	1/2"	1-1/4"	1/4"	2-7/64"	1"	1	D-02325
3/8"	5/8"	1-1/4"	1/4"	2-15/64"	1-1/4"	1	D-02347

Moldura cóncava con balero

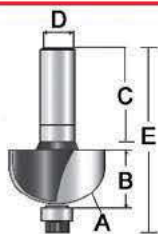

A	B	C	D	E	F	Empaque Piezas	No. Parte
1/4"	9/16"	1-1/8"	1/4"	2"	7/8"	1	D-02397
3/8"	9/16"	1-1/8"	1/4"	2"	1-1/8"	1	D-02406
1/2"	3/4"	1-1/8"	1/4"	2-3/16"	1-3/8"	1	D-02428

Multirebajador con balero

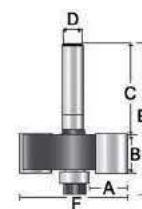
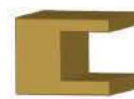

A	B	C	D	E	F	Empaque piezas	No. Parte
3/8", 1/2", 5/8", 3/4"	1/2"	1-5/16"	1/4"	2-1/4"	1-3/8"	1	D-02571

Bisel 45° con balero

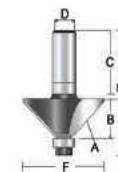

A	B	C	D	E	F	Empaque piezas	No. Parte
21/32"	1/2"	1-1/4"	1/4"	2-5/64"	45mm	1	D-02478
45/64"	47/64"	1-5/16"	1/4"	2-29/64"	15mm	1	D-02509
5/8"	1/2"	1-5/16"	1/2"	2-3/8"	45mm	1	D-02484

Ranuradora 3 filis

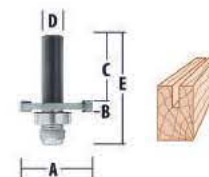

A	B	C	D	E	Empaque piezas	No. Parte
1-7/8"	5/32"	1-1/4"	1/4"	2-1/8"	1	D-02967

Rebajadora con balero



A	B	C	D	E	F	Empaque piezas	No. Parte
3/8"	1/2"	1-1/4"	1/4"	2-5/32"	1-1/4"	1	D-02537

Romana con balero

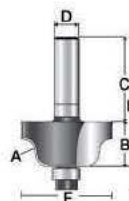

A	B	C	D	E	Empaque piezas	No. Parte
5/32"	5/8"	1-1/4"	1/4"	2-13/64"	1	D-02593
					1	D-02618

El equipo estándar (accesorios), las especificaciones y las fotografías pueden variar. Los accesorios pueden no estar incluidos desde origen con las herramientas aunque se indiquen en este catálogo.

Doble romana con balero

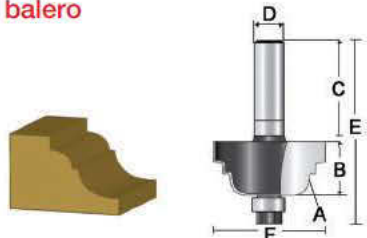

A	B	C	D	E	F	Empaque piezas	No. Parte
1/4"	3/8"	1-1/4"	1/4"	2-1/16"	3/4"	1	D-02652

Borde clásico con balero

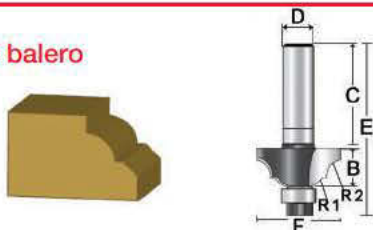

A	B	C	D	E	F	Empaque Piezas	No. Parte
3/4"	1/2"	1-1/4"	1/4"	2-3/16"	7/8"	1	D-02668

Moldura rebajada con rodamiento



A	B	C	D	E	F	Empaque piezas	No. Parte
1/4"	1/2"	1-1/4"	1/4"	2-3/16"	1"	1	D-02680

Moldura cóncava y convexa con balero



A	B	C	D	E	F	Empaque Piezas	No. Parte
1/8"	9/16"	1"	1/4"	2-1/8"	7/8"	1	D-02711

Fresa doble para moldura tipo guarnición

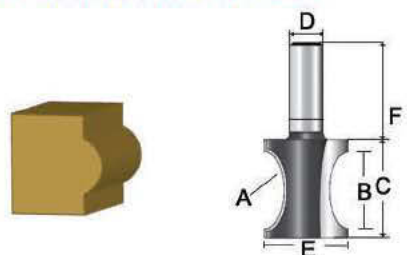

A	B	C	D	E	F	Empaque piezas	No. Parte
23/32"	27/32"	1-1/4"	1/4"	13/16"	2-1/2"	1	D-02749

Fresas para rebaje en formaica

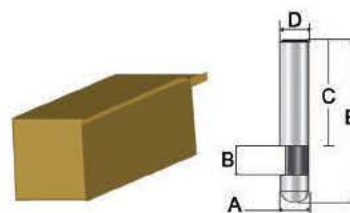

A	B	C	D	E	Empaque piezas	No. Parte
1/4"	1/4"	1-1/16"	1/4"	1-1/2"	1	D-03056

Fresas para rebaje 7

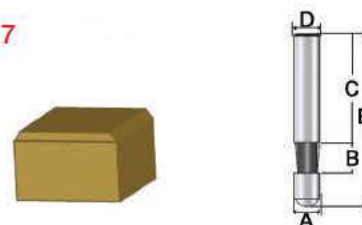

A	B	C	D	E	Empaque piezas	No. Parte
3/16"	1/4"	1-1/16"	1/4"	1-1/2"	1	D-03062

Fresa doble para rebaje en formaica con balero

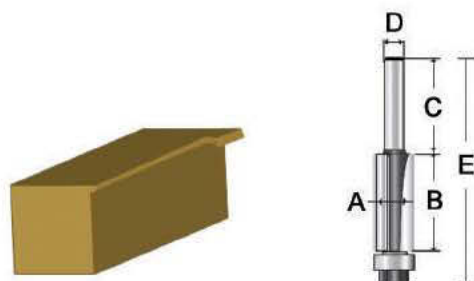

A	B	C	D	E	Empaque piezas	No. Parte
1/4"	1/2"	1"	1/4"	2-1/4"	1	D-03078
3/8"	1/2"	1"	1/4"	2-1/8"	1	D-03084
3/8"	1"	1-1/4"	1/4"	2-5/8"	1	D-03090
1/2"	1/2"	1-1/4"	1/4"	2-1/4"	1	D-03109
1/2"	1"	1-1/4"	1/4"	2-5/8"	1	D-03115
1/2"	1-1/2"	1-1/2"	1/2"	3-7/8"	1	D-03137

Fresa combinada 10

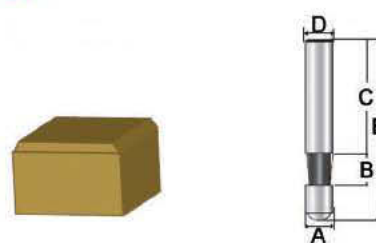

A	B	C	D	E	Empaque piezas	No. Parte
1/4"	3/8"	1"	1/4"	1-1/2"	1	D-03171

ACCESORIOS

Fresas para router

Fresa combinada 23

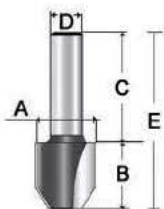

A	B	C	D	E	Empaque piezas	No. Parte
7/16"	1/2"	1-1/4"	1/4"	1-3/4"	1	D-03187

Fresa doble para rebaje 25 con balero 4 hojas

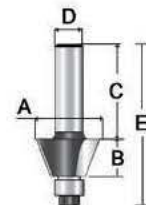

A	B	C	D	E	Empaque piezas	No. Parte
5/8"	3/8"	1-1/4"	1/4"	2-3/8"	1	D-03252

Fresa tipo rebaje en formaica con balero

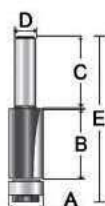

A	B	C	D	E	Empaque piezas	No. Parte
1/2"	1"	1"	1/4"	2-5/8"	1	D-03193

Fresa para router "profesionales"

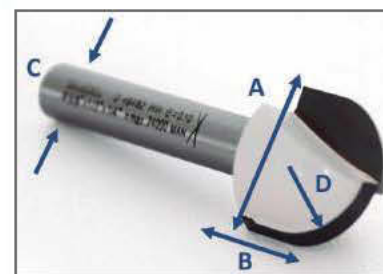

Fresa recta CT



Fresa doble para rebaje 15 con balero

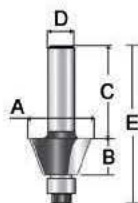

A	B	C	D	E	Empaque piezas	No. Parte
1/2"	9/32"	1"	1/4"	1-7/8"	1	D-03230

Fresa doble para rebaje 25 con balero

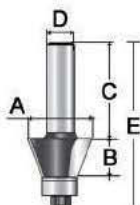

A	B	C	D	E	Empaque piezas	No. Parte
1/2"	9/32"	1"	1/4"	1-7/8"	1	D-03246
*	*	*	1/2"	*	1	D-03143

A	B	C	Filos	Adicional	Empaque piezas	No. Parte
1/8"	1/2"	1/4"	1		1	D-49002
1/4"	3/4"	1/4"	1		1	D-49030
1/4"	1"	1/4"	2		1	D-49052
5/16"	1"	1/4"	2		1	D-49068
3/8"	1"	1/4"	2		1	D-49074
1/2"	1-1/4"	1/4"	2		1	D-49080
1/4"	3/4"	1/4"	2		1	D-49105
5/16"	3/4"	1/4"	2		1	D-49111
3/8"	3/4"	1/4"	2		1	D-49127
1/2"	3/4"	1/4"	2		1	D-49133
1/2"	2-1/2"	1/2"	2		1	D-58512
5/8"	3/4"	1/4"	2		1	D-49155
3/4"	3/4"	1/4"	2		1	D-49177
3/8"	1"	1/2"	2		1	D-49199
1/2"	1-1/4"	1/2"	2		1	D-49208
9/16"	1-1/4"	1/2"	2		1	D-49214
5/8"	1-1/4"	1/2"	2		1	D-49220
3/4"	1-1/4"	1/2"	2		1	D-49236
7/8"	1-1/4"	1/2"	2		1	D-49242
1"	1-1/4"	1/2"	2		1	D-49258

El equipo estándar (accesorios), las especificaciones y las fotografías pueden variar. Los accesorios pueden no estar incluidos desde origen con las herramientas aunque se indiquen en este catálogo.

Fresa para enrasar CT



A	B	C	Filos	Adicional	Empaque piezas	No. Parte
3/8"	1"	1/4"	2	Larga con balero	1	D-49264
1/2"	1/2"	1/4"	2	con balero	1	D-49270
1/2"	1"	1/4"	2	Larga con balero	1	D-49286
1/2"	1"	1/4"	3	con balero	1	D-49292
1/2"	1-1/2"	1/2"	3	con balero	1	D-49301

Fresa cola de milano CT



A	B	C	Filos	Grados	Adicional	No. Parte
5/16"	1/4"	1/4"	2	7.5°	Fresa cola de milano	D-49529
3/8"	1/4"	3/8"	2	9°	Fresa cola de milano	D-49535
1/2"	1/4"	1/2"	2	14°	Fresa cola de milano	D-49541
7/8"	1/2"	3/4"	2	7°	Fresa cola de milano	D-49563

Fresa para enrasar formaica



A	B	C	Filos	Adicional	Empaque piezas	No. Parte
1/4"	1/2"	1/4"	2	con balero	1	D-58528
3/8"	1/2"	1/4"	2	con balero	1	D-58534
1/2"	1"	1/2"	2	con balero	1	D-58540



Fresa piloto CT



A	B	C	Filos	Adicional	Empaque Piezas	No. Parte
1/4"	3/4"	1/4"	1	Fresa para copiar	1	D-49317
3/8"	1"	1/2"	1	Fresa para copiar	1	D-49323
1/2"	1-17/64"	1/2"	1	Cortar y perfilar	1	D-58556
1/2"	3/4"	1/4"	2	Mortajar p/ bisagra	1	D-58562

Fresa para redondear CT



A	B	C	Filos	Adicional	Empaque piezas	No. Parte
1/8"	3/8"	1/4"	2	Fresa para redondear	1	D-49769
3/16"	1/2"	1/4"	2	Fresa para redondear	1	D-49775
1/4"	17/32"	1/4"	2	Fresa para redondear	1	D-49781
5/16"	9/16"	1/4"	2	Fresa para redondear	1	D-49797
3/8"	21/32"	1/4"	2	Fresa para redondear	1	D-49806
1/2"	3/4"	1/4"	2	Fresa para redondear	1	D-49812
3/4"	1/2"	1/2"	2	Fresa para redondear	1	D-49828

Fresa para ranurar CT



A	B	C	Filos	Diámetro	Adicional	No. Parte
1/4"	1/4"	1/4"	2	1/8"	Fresa para ranurar	D-49448
3/8"	3/8"	1/4"	2	3/16"	Fresa para ranurar	D-49460
1/2"	3/8"	1/4"	2	1/4"	Fresa para ranurar	D-49476
5/8"	1/2"	1/4"	2	5/16"	Fresa para ranurar	D-49482



ACCESORIOS

Fresa para moldura CT



A	B	C	Filos	Adicional	Empaque piezas	No. Parte
3/16"	1/2"	1/4"	2	Fresa para moldura	1	D-49840
1/4"	17/32"	1/4"	2	Fresa para moldura	1	D-49856
5/16"	9/16"	1/4"	2	Fresa para moldura	1	D-49862
3/8"	21/32"	1/4"	2	Fresa para moldura	1	D-49878
1/2"	3/4"	1/4"	2	Fresa para moldura	1	D-49884

Fresa media caña CT



A	B	C	Filos	Adicional	Empaque piezas	No. Parte
3/16"	1/2"	1/4"	2	Fresa media caña	1	D-49943
3/8"	17/32"	1/4"	2	Fresa media caña	1	D-49965
1/2"	5/8"	1/4"	2	Fresa media caña	1	D-49971

Fresa para ensamble CT



A	B	C	Filos	Adicional	Empaque piezas	No. Parte
3/8"	1/2"	1/4"	2	Fresa ensamble	1	D-50061
3/8"	1/2"	1/2"	2	Fresa ensamble	1	D-50077

Fresa romana CT



A	B	C	Filos	Adicional	Empaque Piezas	No. Parte
5/32"	1/2"	1/4"	2	Fresa romana	1	D-50083
1/4"	11/16"	1/2"	2	Fresa romana	1	D-50099

Fresas para router

Fresa ojo de cerradura CT



A	B	C	Filos	Adicional	Empaque piezas	No. Parte
3/8"	13/32"	1/4"	1	Fresa ojo de cerradura	1	D-50217

Fresa ranuradora CT



A	B	C	Filos	Adicional	Empaque Piezas	No. Parte
1/2"	5/64"	1/4"	2	Fresa ranuradora	1	D-50245
1/2"	3/32"	1/4"	2	Fresa ranuradora	1	D-50251
1/4"	1/8"	1/4"	2	Fresa ranuradora	1	D-50267
1/2"	5/32"	1/4"	2	Fresa ranuradora	1	D-50273
1/2"	3/16"	1/4"	2	Fresa ranuradora	1	D-50289
1/2"	7/32"	1/4"	2	Fresa ranuradora	1	D-50295

Fresa para exhibidor de panel CT

A	B	C	Filos	Adicional	Empaque Piezas	No. Parte
1/2"			2		1	D-61868

Fresa recta 2 filos con balero superior

A	B	C	Filos	Adicional	Empaque piezas	No. Parte
1/2"	1/4"	1/4"	2	Fresa recta	1	D-58497
1/2"	1"	1/4"	2	Fresa recta	1	D-58506

Juego de fresas para router

Punta ranuradora 1/4"

Punta bisel 1/2"

Punta media luna 1/2"



No. Parte
D-16461

El equipo estándar (accesorios), las especificaciones y las fotografías pueden variar. Los accesorios pueden no estar incluidos desde origen con las herramientas aunque se indiquen en este catálogo.

Nueva línea de fresas para router zanco 1/2"

Fresa recta 1 filo

A	B	C	Filos	Adicional	Empaque piezas	No. Parte
1/4"	3/4"	1/2"	1	Fresa recta	1	D-62739
3/8"	1"	1/2"	1	Fresa recta	1	D-62745

Fresa recta 2 filos

A	B	C	Filos	Adicional	Empaque piezas	No. Parte
1/4"	3/4"	1/2"	2	Fresa recta	1	D-62751
5/16"	1"	1/2"	2	Fresa recta	1	D-49183
1/2"	1"	1/2"	2	Fresa recta	1	D-62767
1/2"	1-1/2"	1/2"	2	Fresa recta	1	D-62773
3/4"	1"	1/2"	2	Fresa recta	1	D-62789
3/4"	1-1/2"	1/2"	2	Fresa recta	1	D-62795
7/8"	1"	1/2"	2	Fresa recta	1	D-62804

Fresa recta súper

A	B	C	Filos	Adicional	Empaque Piezas	No. Parte
1/2"	2"	1/2"	2		1	D-62810

Fresa recta patern

A	B	C	Filos	Adicional	Empaque Piezas	No. Parte
3/4"	1"	1/2"	2		1	D-62826

Fresa p/enrasar formaica con balero

A	B	C	Filos	Adicional	Empaque Piezas	No. Parte
1/2"	1-1/2"	1/2"	2	Fresa p/ enrasar	1	D-62832
1/2"	2"	1/2"	2	Fresa p/ enrasar	1	D-62848
3/4"	1"	1/2"	2	Fresa p/ enrasar	1	D-62854
3/4"	1-1/4"	1/2"	2	Fresa p/ enrasar	1	D-62860

Fresa p/ ranurar Media caña

A	B	C	Filos	Adicional	Empaque piezas	No. Parte
3/8"	1/2"	1/2"	2	Fresa ranuradora	1	D-62876
1/2"	3/4"	1/2"	2	Fresa ranuradora	1	D-62882
3/4"	1"	1/2"	2	Fresa ranuradora	1	D-62898

Fresa p/ranurar en "V"

A	B	C	Filos	Adicional	Empaque piezas	No. Parte
1/2"	1/2"	1/2"	2	Fresa ranuradora	1	D-49404
5/8"	1/2"	1/2"	2	Fresa ranuradora	1	D-49410
7/8"	5/8"	1/2"	2	Fresa ranuradora	1	D-62907
3/4"	5/8"	1/2"	2	Fresa ranuradora	1	D-49426
1"	3/4"	1/2"	2	Fresa ranuradora	1	D-62913
1-1/8"	7/8"	1/2"	2	Fresa ranuradora	1	D-49432

Fresa tipo "V"

A	B	C	Filos	Adicional	Empaque piezas	No. Parte
1/4"	1/4"	1/2"	2	Fresa tipo V	1	D-62929
5/16"	5/16"	1/2"	2	Fresa tipo V	1	D-62935
3/8"	3/8"	1/2"	2	Fresa tipo V	1	D-62941
1/2"	3/8"	1/2"	2	Fresa tipo V	1	D-62957
5/8"	1/2"	1/2"	2	Fresa tipo V	1	D-49498
3/4"	1/2"	1/2"	2	Fresa tipo V	1	D-49507
1"	5/8"	1/2"	2	Fresa tipo V	1	D-49513
1"	11/16"	1/2"	2	Fresa tipo V	1	D-62963
1-1/4"	3/4"	1/2"	2	Fresa tipo V	1	D-62979
1-1/2"	7/8"	1/2"	2	Fresa tipo V	1	D-62985

Fresa cola de milano

A	B	C	Filos	Adicional	Empaque piezas	No. Parte
3/8"	3/8"	1/2"	2	Fresa cola de milano	1	D-62991
1/2"	1/2"	1/2"	2	Fresa cola de milano	1	D-63002
1"	7/8"	1/2"	2	Fresa cola de milano	1	D-49579

Fresa clasica

A	B	C	Filos	Adicional	Empaque piezas	No. Parte
1"	5/8"	1/2"	2	Fresa clasica	1	D-49694
1-1/4"	3/4"	1/2"	2	Fresa clasica	1	D-49703

Fresa p/ ranurar Romana

A	B	C	Filos	Adicional	Empaque piezas	No. Parte
3/4"	7/16"	1/2"	2	Fresa romana	1	D-63018

Fresa p/ perfilar

A	B	C	Filos	Adicional	Empaque Piezas	No. Parte
3/4"	3/8"	1/2"	2	Fresa p/ perfilar	1	D-63024
1/2"	1"	1/2"	2	Fresa p/ perfilar	1	D-63030

Fresa p/ redondear

A	B	C	Filos	Adicional	Empaque Piezas	No. Parte
5/8"	15/32"	1/2"	2	Fresa p/ redondear	1	D-63046
3/4"	3/8"	1/2"	2	Fresa p/ redondear	1	D-63052
1-1/4"	21/32"	1/2"	2	Fresa p/ redondear	1	D-63068
1-1/2"	3/4"	1/2"	2	Fresa p/ redondear	1	D-63074

Fresa cóncava con balero

A	B	C	Filos	Adicional	Empaque Piezas	No. Parte
1-1/4"	17/32"	1/2"	2	Fresa cóncava	1	D-63080
1-1/2"	5/8"	1/2"	2	Fresa cóncava	1	D-63096
1-3/4"	3/4"	1/2"	2	Fresa cóncava	1	D-63105
2"	7/8"	1/2"	2	Fresa cóncava	1	D-63111

Fresa p/ perfilados

A	B	C	Filos	Adicional	Empaque piezas	No. Parte
2"	1"	1/2"	2	Fresa p/perfilados	1	D-49890

Fresa cóncava 2 filos c/ balero

A	B	C	Filos	Adicional	Empaque piezas	No. Parte
1-1/4"	19/32"	1/2"	2	Fresa cóncava	1	D-63127

Fresa p/ biselar 45° con balero

A	B	C	Filos	Adicional	Empaque piezas	No. Parte
1-3/4"	29/32"	1/2"	2	Fresa clasica	1	D-50049
2"	1-1/16"	1/2"	2	Fresa clasica	1	D-50055

Fresa p/ barandilla Tipo pez

A	B	C	Filos	Adicional	Empaque piezas	No. Parte
1-1/8"	1-5/8"	1/2"	2	Fresa tipo pez	1	D-50158

Fresa p/ moldura cóncava

A	B	C	Filos	Adicional	Empaque piezas	No. Parte
1-3/4"	1-1/8"	1/2"	2	Fresa cóncava	1	D-50164

Fresa p/ moldura multiforma

A	B	C	Filos	Adicional	Empaque piezas	No. Parte
2-1/4"	1-7/8"	1/2"	2	Fresa cóncava	1	D-50186

El equipo estándar (accesorios), las especificaciones y las fotografías pueden variar. Los accesorios pueden no estar incluidos desde origen con las herramientas aunque se indiquen en este catálogo.

Fresa p/ machi-hembrar

A	B	C	Filos	Adicional	Empaque piezas	No. Parte
1-39/64"	3/4"	1/2"	4		1	D-50239

Fresa piloto p/ copiar

A	B	C	Filos	Adicional	Empaque piezas	No. Parte
1/2"	1-1/8"	1/2"	2	Fresa piloto	1	D-63133

Fresa p/ bisagra

A	B	C	Filos	Adicional	Empaque piezas	No. Parte
1/2"	3/4"	1/2"	2	Fresa p/ bisagra	1	D-63149

Fresa p/ moldura Nariz de toro

A	B	C	Filos	Adicional	Empaque piezas	No. Parte
7/8"	3/4"	1/2"	2	Fresa p/ moldura	1	D-63155

Fresa p/ moldura Romana

A	B	C	Filos	Adicional	Empaque piezas	No. Parte
1-1/4"	1-27/64"	1/2"	2	Fresa p/ moldura	1	D-63161

Fresa p/ ranurar "V"

A	B	C	Filos	Adicional	Empaque piezas	No. Parte
3/8"	3/8"	1/2"	2	Fresa p/ ranurar	1	D-63177

Fresa p/ moldura cóncava y convexa

A	B	C	Filos	Adicional	Empaque piezas	No. Parte
1"	11/16"	1/2"	2	Fresa p/ moldura	1	D-63183
1-1/8"	3/4"	1/2"	2	Fresa p/ moldura	1	D-63199

Fresa nariz de toro c/ balero

A	B	C	Filos	Adicional	Empaque piezas	No. Parte
3/4"	5/8"	1/2"	2	Fresa nariz de toro	1	D-63208
7/8"	1"	1/2"	2	Fresa nariz de toro	1	D-63214
1/2"	1"	1/2"	2	Fresa nariz de toro	1	D-63220

Fresa p/ moldura clasica

A	B	C	Filos	Adicional	Empaque piezas	No. Parte
1-3/8"	5/8"	1/2"	2	Fresa tipo pez	1	D-63236

Fresa p/ moldura triple grano

A	B	C	Filos	Adicional	Empaque piezas	No. Parte
7/8"	1"	1/2"	2	Fresa cóncava	1	D-63242

Fresa p/ barandilla

A	B	C	Filos	Adicional	Empaque piezas	No. Parte
1-3/8"	1-1/2"	1/2"	2	Fresa cóncava	1	D-63258

ACCESORIOS

Fresas para router

Set de 6 fresas para router

No. Parte **D-53578**



Diámetro	Longitud	Radio	Ángulo	Zanco	Cojinete	Flauta	No. Parte
1/4"	5/8"	-	-	1/4"	-	2	D-49096
3/8"	3/4"	-	-	1/4"	-	2	D-49127
1/2"	3/4"	-	-	1/4"	-	2	D-49133
1/2"	3/8"	1/4"	-	1/4"	-	2	D-49476
1-1/4"	21/32"	3/8"	-	1/4"	1/2"	2	D-49806
1-1/8"	1/2"	5/32"	-	1/4"	1/2"	2	D-50083

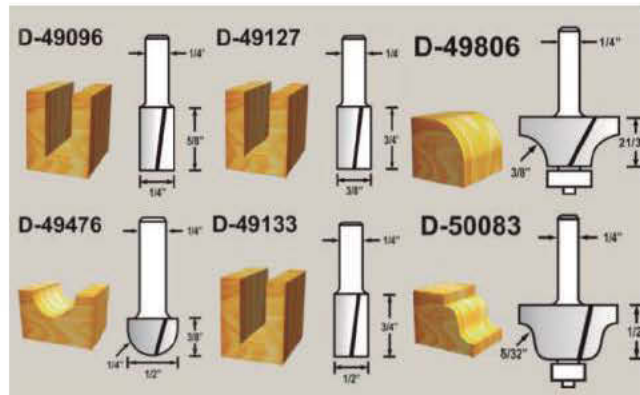

Set de 12 fresas para router

No. Parte **D-53584**



Diámetro	Longitud	Radio	Ángulo	Zanco	Cojinete	Flauta	No. Parte
1/4"	5/8"	-	-	1/4"	-	2	D-49096
1/2"	3/4"	-	-	1/4"	-	2	D-49133
5/8"	3/4"	-	-	1/4"	-	2	D-49155
1/2"	1/2"	-	-	1/4"	1/2"	2	D-49270
1/2"	1/2"	-	14dg	1/4"	-	2	D-49541
1/2"	1/2"	-	90dg	1/4"	-	2	D-49389
1/2"	3/8"	1/4"	-	1/4"	-	2	D-49476
1"	17/32"	1/4"	-	1/4"	1/2"	2	D-49781
1/1/4"	21/32"	3/8"	-	1/4"	1/2"	2	D-49806
1-1/4"	17/32"	3/8"	-	1/4"	1/2"	2	D-49965
1-1/4"	17/32"	-	45dg	1/4"	1/2"	2	D-50011
1-1/8"	1/2"	5/32"	-	1/4"	1/2"	2	D-50083

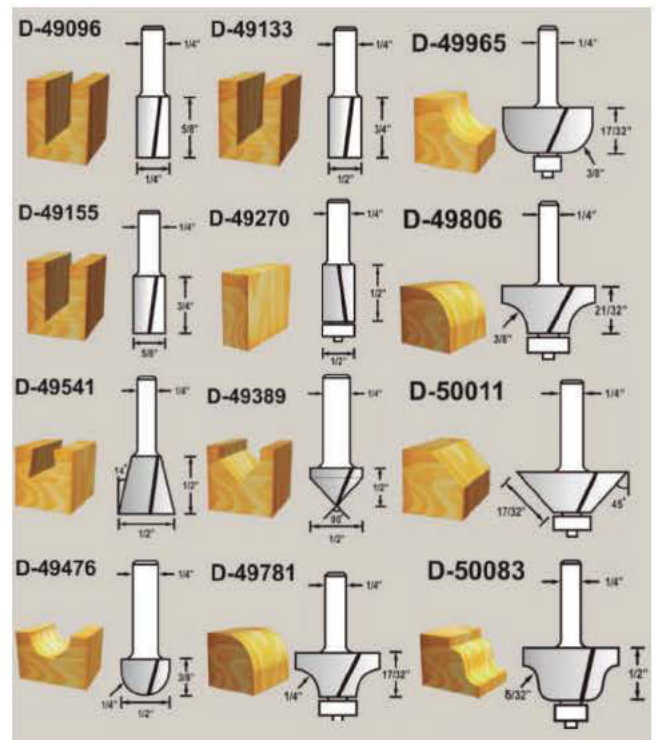

El equipo estándar (accesorios), las especificaciones y las fotografías pueden variar. Los accesorios pueden no estar incluidos desde origen con las herramientas aunque se indiquen en este catálogo.

Equipo para exterior



Sistema multiherramienta

Capaz de satisfacer una amplia gama de necesidades gracias a la versatilidad en accesorios* (EX2650LH - HXU02Z)

Sistema de acoplamiento rápido para un cambio fácil y sencillo de los accesorios

*Se venden por separado, (Accesorios no incluidos en la herramienta)



Los artículos del equipo estándar y las especificaciones pueden variar según el país o área.

Accesorios para desbrozadora

Cuchillas

	Usar en	Aplicación	Medidas	Empaque Pieza	No. Parte
	RBC411, RBC411U, RBC412U	Para corte de ramas cuchilla 2 filos		1	195624-6
		Cuchilla de 3 filos plásticos para segar hierba alta	255mm	1	197188-6
		Cuchilla curva de 3 filos plásticos para segar hierba alta		1	198384-9
	197188-6	Repuesto hoja plástica		1	197189-4
	EBH340U, EM4351UH, EM4350UH	Para corte de ramas y arbustos. cuchilla 3 filos 255mm		1	195299-1
	EBH252U	Para corte de ramas y arbustos. cuchilla 3 filos 230mm		1	195298-3
		Para corte de ramas y arbustos. cuchilla 3 filos 230mm		1	195300-2
		Cabeza recortadora c/ centro metálico		1	197030-1
	EM2653L	Cortador de ensamble 95-M10L		1	197804-0

	Usar en	Aplicación	Medidas	Empaque Pieza	No. Parte
	EM2653L	Cuchilla 230mm	230mm	1	197808-2
	EM2500U	Para corte de césped y arbustos. 4 dientes (cruzeta)	255mm x 25,4mm x 1,8 mm.	1	B-14124
	EM2500U	Para corte de césped y arbustos, 4 Filos.		1	DA00000169
	EM2500U	Para corte de césped y arbustos, 4 filos. (con empaque)		1	DA00000181
		Cuchilla 8 filos tipo remolino	230mm x 1,8mm	1	B-14130
		Cuchilla 8 filos tipo remolino	255mm x 2,0mm	1	B-14146
		Para corte de ramas y arbustos, tipo sierra, con dientes de carburo de tungsteno 40 dientes	230mm x 32mm	1	A-56932
	EM2653L	Jgo. de protector 420		1	197806-6

El equipo estándar (accesorios), las especificaciones y las fotografías pueden variar. Los accesorios pueden no estar incluidos desde origen con las herramientas aunque se indiquen en este catálogo.

Cabezas para hilo



Usar en	Aplicación	Medidas	Empaque Piezas	No. Parte
EM4250, EM4340, RBC251, RBC320, RBC411	Corte de césped, sistema de cuerda autoalimentable, giro izquierdo incluye adaptadores	110 x 8 x 1.25mm (Rh)	1	B-60109
RST250	Corte de césped, sistema de cuerda autoalimentable, giro derecho incluye adaptadores	110 x 8 x 1.25 mm (Lh)	1	B-60121
RBC251	Corte de césped, sistema de cuerda autoalimentable, giro derecho incluye adaptadores	110 x 8 x 1.25 mm (Lh)	1	B-60143
EM4250, EM4340	Corte de césped, sistema de cuerda autoalimentable, giro izquierdo	110 x 6 x 1.25mm (Lh)	1	A-89121
	Corte de césped, sistema de cuerda autoalimentable, giro izquierdo	125 x 6 x 1.25mm (Lh)	1	A-89143
EBH340U	Corte de césped, sistema de cuerda autoalimentable, giro izquierdo	125 x 6 x 1.25mm (Lh)	1	1229314
EBH252U, EM4340, EBH340U, RBC411	Corte de césped, sistema de cuerda autoalimentable, giro izquierdo	M10 x 1.25 LH	1	1951490
EM4340, EBH340U, RBC411, RBC420	Corte de césped, sistema de cuerda autoalimentable, giro izquierdo	M10 x 1.25 LH	1	A-81658
EBH252U, RBC2510, RBC3100, RBC411, BRC411U	Corte de césped, sistema de cuerda autoalimentable, giro izquierdo	M8 x 1.25 L	1	B-01959
EBH252U, EBH252L, EBH340U, EBH340R			1	B-02945
Universal	Corte de césped, sistema manual P/ suministro de cuerda	4-1/2"	1	B-02951
EM4350UH, EM4351UH	Cabeza recortadora ultra-auto 6		1	122882-1

Protectores y guardas



Características	Empaque piezas	No. Parte
Guarda	1	170043110
Protector ASSY	1	6348007001
Protector completo	1	6258053001
Protector con extensión	1	135398-7
Protector	1	6348008001
Protector	1	6348001001
Protector	1	6348001000
Protector	1	6258028002
Protector	1	6258060001
Protector	1	6248002000
Protector	1	6258061001

Hilo de nylon para DUR364L



Características	Empaque piezas	No. Parte
Hilo de nylon 2.0 p/ DUR364L	15mt	197472-9
Hilo de nylon 2.0 p/ DUR364L	30mt	197473-7
Hilo de nylon 2.0 p/ DUR364L	160mt	197474-5
Hilo de nylon 2.0 p/ DUR364L	280mt	197475-3

Industriales

- NORMAL
- PLUS
- PRO



369224609



369224607



369224602



369224601

B-01971	HILO NYLON REDONDO 2.4mm x 5m
B-07375	HILO NYLON REDONDO 3.0mm x 4m
369224600	HILO NYLON REDONDO 2.0 mm x 15m.
36922460 1	HILO NYLON REDONDO 2.0 mm x 126m.
36922460 2	HILO NYLON REDONDO 2.4 mm x 15m.
36922460 4	HILO NYLON REDONDO 2.4 mm x 262m.
36922460 6	HILO NYLON CUADRADO 2.4 mm x 15m
36922460 7	HILO NYLON CUADRADO 2.4 mm x 69m.
36922460 8	HILO NYLON CUADRADO 2.4 mm x 206m.
36922460 9	HILO NYLON REDONDO 3.0 mm x 15m.
3692246 11	HILO NYLON REDONDO 3.0 mm x 168m.
3692246 12	HILO NYLON REDONDO 3.0 mm x 279m.
3692246 13	HILO NYLON CUADRADO 3.0 mm x 15m.
3692246 14	HILO NYLON CUADRADO 3.0 mm x 44m.
3692246 15	HILO NYLON CUADRADO 3.0 mm x 132m.
3692246 16	HILO NYLON CUADRADO 3.0 mm x 219m.

Profesionales



T-02434



T-02397
T-02375
T-02381



T-02406
T-02412
T-02428

T-02375	HILO NYLON REDONDO 2.0mm x 270m
T-02381	HILO NYLON REDONDO 2.5mm x 170m
T-02397	HILO NYLON REDONDO 3 mm x 120m.
T-02406	HILO NYLON CUADRADO 2 mm x 230m.
T-02412	HILO NYLON CUADRADO 2.5 mm x 140m.
T-02428	HILO NYLON CUADRADO 3 mm x 100m.
T-02434	HILO NYLON CUADRADO/RECUBIERTO 3 mm x 120m

Cortasetos



Para usar en	Aplicación	Empaque piezas	No. Parte
Desbrozadoras a gasolina 2.64 Tiempos	Recorte de ramas y arbustos con acabado estético	1	A-89523
EN410MP	Recorte de ramas y arbustos con acabado estético	1	197738-7

Complementos



Usar en	Aplicación	Medidas	Empaque Piezas	No. Parte
RBC411	Gancho soporte para herramienta		1	6417014150
Recolector	Tubo para recolector de café de 1.0m		1	1952496 1952527
EBH340R	Botella para mezcla de combustible 2 tiempos 25:1 botella de aceite		1	5609004000
EBH340R	Botella para mezcla de combustible 2 tiempos 25:1 botella de aceite		1	0722105000
Cabeza recortadora B60109	Juego de guías metálicas para hilo		Juego 2 pzs.	A-15992
EBH340R	Cubierta de plástico negra		1	6418500701
EBH340R	Cubierta de plástico		1	6418027000
RBC411	Kit de mantenimiento		1	6419038001
Varios	Llave de bujía p/ motosierras	6mm. (1/4")	1	941713001
EN5950SH	Barra guía p/ cortasetos		1	725184-0
EN5950SH	Laina guía p/ cortasetos		1	346666-5
EN5950SH	Cuchilla p/ cortasetos		1	332059-2
EX2650LHM	Maleta Makita		1	831342-9
EY2650H25H	Cadena 10" p/ motosierra de extensión		1	196142-7
EX2650LHM	Accesorio p/ desbrozadora (incluye cabezal)		1	195645-8

Accesorios para equipo de combustión

Aspersores y adaptadores



Usar en	Descripción	Empaque Piezas	No. Parte
EBH1000X	Palanca de control	1	6255008000
EBH1000X	Llave de paso	1	5929002000
EVH2000	Adaptador	1	ADAPTER
EVH2000	Medidor	1	6909035001
EVH2000	Tubo de aspersor completo	1	6909039000
EVH2000	Tubo de aspersor	1	6909511500
EVH2000	Aspersor	1	6919500500

Cosechador de café

Sacude ramas



Usar en	Aplicación	Empaque Piezas	No. Parte
Desbrozadoras a gasolina 2 ó 4 tiempos	Sacude las ramas para desprender los frutos en plantas de café y olivos (aceituna)	1	B-80210
Desbrozadoras a gasolina 2 ó 4 tiempos	Sacude las ramas para desprender los frutos en plantas de café y olivos (aceituna)	1	B-80226
Desbrozadoras a gasolina 2 ó 4 tiempos	Sacude las ramas para desprender los frutos en plantas de café y olivos (aceituna)	1	197163-2

Accesorios para nebulizador PM7650H



Usar en	Aplicación	Empaque Piezas	No. Parte
PM7650H	Correa de hombro (L) izquierda	1	161509-8
PM7650H	Correa de hombro (R) derecha	1	161510-3
PM7650H	Set de boquillas 0.7/0.8mm	1	196499-6
PM7650H	Boquilla 0.5mm	1	196616-8
PM7650H	Tubo curvo 630 f	1	453507-9
PM7650H	Tubo recto 380	1	453700-5
PM7650H	Tubo recto 630	1	453699-4
PM7650H	Tapa pulverizadora	1	453506-1

Accesorios para sopladora



Usar en	Aplicación	Empaque Piezas	No. Parte
BHX2500	Kit bolsa recolectora P/BHX2500	1	1952828
BHX2500	Boquilla plana P/BHX2500	1	6659501100
BHX2500	Kit bolsa recolectora P/BHX2500	1	6659504000
MUB105	Ensamble de bolsa para polvo	1	123241-2
DUB182	Bolsa para polvo	1	122814-8

Arnés para desbrozadora



Usar en	Aplicación	Empaque Piezas	No. Parte
Desbrozadoras a gasolina 2 ó 4 tiempos	Arnés de soporte para desbrozadoras	1	125802-4
Adecuado para EM4350LH	Arnés de soporte tipo sencillo (Para usuario del hogar)	1	126187-1
Adecuado para EM4350UH	Arnés de soporte trabajo medio pesado (Para usuario agricultor)	1	122906-3
Adecuado para EM4351UH	Arnés de soporte trabajo pesado (Para usuario profesional)	1	196129-9

El equipo estándar (accesorios), las especificaciones y las fotografías pueden variar. Los accesorios pueden no estar incluidos desde origen con las herramientas aunque se indiquen en este catálogo.

Cosechador



Usar en	Aplicación	Empaque piezas	No. Parte
EBH340U	Cosecha de alfalfa	1	EB400MP

Barras para motosierra



Usar en	Descripción	Empaque piezas	No. Parte
DCS250T	Barra guía 10"	1	1684085
BUC122	Barra guía 12"	1	1584766
BUC122	Barra guía 12"	1	1684506

Tubo telescópico completo

Para EY2650H

Aplicación	Usar en	Empaque piezas	No. Parte
	EY2650H	1	142603-5

Barra guía para motosierra

* 415045751: Usar con cadena (957696064)
Corte de metal (dientes de carburo)



Tipo de nariz	Longitud	Paso	Calibre	Usar en	No. Parte
Sólida	11.5cm/4-1/2"	3/8"	0.043"	UC120D	158045-3
Sprocket	35cm/14"	3/8"	0.050"	DCS34	442035661
Sólida	35cm/14"	3/8"	0.050"	EA3200530A	443035661
Sprocket	40cm/16"	3/8"	0.050"	DCS460, EA3200540A, DCS3416, EA3200530A	442040661
Sólida	45cm/18"	3/8"	0.058"	DCS6401	445045455
Sprocket	45cm/18"	3/8"	0.058"	DCS50018, DCS7301	443045651
Sprocket	45cm/18"	3/8"	0.058"	DCS50018	*415045751
Sólida	50cm/20"	3/8"	0.058"	DCS7301	445050455
Sprocket	50cm/20"	3/8"	0.058"	DCS640120	445050655
Sprocket	53cm/21"	3/8"	0.058"	DCS5200 DCS520	443053651
Sprocket	50cm/20"	3/8"	0.058"	DCS510, DCS5200	443053661
Sólida	60cm/24"	3/8"	0.058"	DCS640124	445060455
Sprocket	60cm/24"	3/8"	0.058"	DCS640124	445060655
Sólida	70cm/28"	3/8"	0.058"	DCS730128, DCS7901	445070455
Sólida	74cm/29"	3/8"	0.058"	DCS730128, DCS910	445074452

Funda



Usar en	Aplicación	Empaque piezas	No. Parte
Espada	Funda protectora de vinil negra para espada	1	635750000

Cadenas para motosierra



Longitud	Paso	Calibre	Forma del diente	Usar en	No. Parte
35cm/14"	3/8"	0.050"	HALF	DCS3400/ DCS3501	528092652
40cm/16"	3/8"	0.050"	HALF	DCS3400/ DCS4300	531492656
45cm/18"	3/8"	0.058"	HALF	DCS460 DCS6000	523093664
53cm/21"	3/8"	0.058"	HALF	DCS461 DCS6000	523093672
45cm/18"	3/8"	0.058"	FULL	DCS4600 DCS6000	528099664
53cm/21"	3/8"	0.058"	FULL	DCS5000 DCS6000	528099672
45cm/18"	3/8"	0.058"	FULL	DCS6400	528099668
60cm/24"	3/8"	0.058"	FULL	DCS7300	528099684
70cm/28"	3/8"	0.058"	FULL	DCS7301	528099694
74cm/29"	3/8"	0.058"	FULL	DCS9010	528099696

Limas para motosierra



Descripción	Medida	Usar en	No. Parte
			953003060
Lima redonda	4mm(5/32")		953003070
Lima redonda	4.5mm(11/64")	UC3020A, UC3520A,UC4020A	953003100
Lima redonda	5.5mm(7/32")		953603040
Lima redonda	4mm(5/32")		953003090
Mango para lima			953004010
Calibrador para cadena	1/4"		953100090

Accesorios para herramienta inalámbrica

Descripción	Aplicación	Usar en	Empaque piezas	No. Parte
Cadena para motosierra	Sierra de cadena	5012B	1	791172-9



1 Espada: Fabricada cuidadosamente con la mejor aleación de acero para espada de cadena y larga vida.

2 Nariz: En el área de la nariz, la cadena no está en contacto con la espada, sino que está montada sobre la estrella, para menos fricción, mayor rendimiento y más larga vida.

Tope de profundidad para barras de motosierra



Usar con	Descripción	Usar en	No. Parte
Barra guía 415045751 Cadena 957696064	Tope de profundidad	DCS50018	957250100
c/cadena 957696064	Tope de profundidad	DCS50018	957415060

Careta de seguridad

	Descripción	Empaque pieza	No. Parte
	Careta de seguridad	1	T-02515
	Careta de seguridad	1	T-02521

Cuñas



Usar en	Aplicación	Empaque Piezas	No. Parte
Auxiliar en el corte de troncos	Cuña metálica 25cm.	1	988070101
Auxiliar en el corte de troncos	Cuña plástica 14cm.	1	988070819
Auxiliar en el corte de troncos	Cuña plástica 20cm.	1	988070824

Aceites para cadena

	Descripción	Empaque pieza	No. Parte
	Aceite biodegradable p/ cadena	5Lts.	980008211
	Aceite biodegradable p/ cadena	20Lts.	980008213
	Aceite biodegradable p/ cadena	55Lts.	980008217
	Aceite mineral p/ cadena	1L.	988002256
	Aceite mineral p/ cadena	60Lts.	988002265
	Aceite para cadena anticorrosión	25ml.	980008302

Juego de herramientas para motosierra



Aplicación	Empaque piezas	No. Parte
Juego de herramientas para motosierra	Juego	988050211

El equipo estándar (accesorios), las especificaciones y las fotografías pueden variar. Los accesorios pueden no estar incluidos desde origen con las herramientas aunque se indiquen en este catálogo.

Tope de profundidad para barras de motosierra

	Descripción	Empaque Pieza	No. Parte
	Aceite para cadena biotop	1L.	980008610
	Aceite para cadena biotop	5Lts.	980008611
	Aceite para cadena biotop (DOLMAR)	60Lts.	980008265
	Aceite para cadena	1L.	988002656
	Aceite para cadena	5L	988002658

Careta de seguridad

	Descripción	Empaque Pieza	No. Parte
	Aceite p/ motor de dos tiempos 1:50	5L	980008118
	Aceite dos tiempos DOLMAR	60L	980008270
	Aceite de dos tiempos sintético DOLMAR	100ml	980008104
	Aceite de dos tiempos sintético DOLMAR	1L	980008103
	Aceite de dos tiempos sintético DOLMAR	5L	980008102
	Aceite de cuatro tiempos 10W-40 MULTIGRADO	80ml	980008123
	Aceite de cuatro tiempos 10W-40 MULTIGRADO	100ml	980008124
	Aceite de cuatro tiempos 5W-30 MULTIGRADO	1L	980008121
	Aceite p/ motor de cuatro tiempos SAE-30	600ml	980508620
	Aceite de cuatro tiempos	600ml	980308620
	Aceite de cuatro tiempos especial para la EK7651H	220ml	195532-1

Lubricantes para motosierra

	Descripción	Empaque Pieza	No. Parte
	Aceite p/ motor de dos tiempos con dosificador DOLMAR	1L	980008112
	Aceite p/ motor de dos tiempos 1:50	100ml	980008606
	Aceite p/ motor de dos tiempos 1:50	1L	980008607
	Aceite p/ motor de dos tiempos 1:50 con dosificador	1L	980008608
	Aceite p/ motor de dos tiempos 1:50	5L	980008618

ACCESORIOS

Equipo para exterior

Motocultivador

Arador zurcador



Usar en	Empaque piezas	No. Parte
Motocultivador KR0751H / KR0700H	1	A-49105
Motocultivador KR0751H / KR0700H	1	A-49127

Broca para ahoyadora (motoperforador)



Usar en	Descripción	Empaque Piezas	No. Parte
PE3450H	Broca 2-14" x 2.5" x 30"	1	T-01862
PE3450H	Broca 3-1/4" x 3.5" x 30"	1	T-01878
PE3450H	Broca 4" x 5.2" x 30"	1	T-01884
PE3450H	Broca 6" x 7.5" x 30"	1	T-01890
PE3450H	Broca 8" x 9.5" x 30"	1	T-01909
PE3450H	Extensión para broca 12"	1	T-01915
PE3450H	Punta centradora para broca 3"	1	T-01921
PE3450H	Punta centradora para broca 1"	1	T-01937
PE3450H	Cuchillas reemplazables 4"	1	T-01943
PE3450H	Cuchillas reemplazables 6"	1	T-01959
PE3450H	Cuchillas reemplazables 8"	1	T-01965
PE3450H	Adaptador p/ broca de sthll	1	T-01971

Accesorios para tronzadora de concreto



Usar en	Descripción	Empaque Piezas	No. Parte
DPC7331	Carrito de transporte para tronzadora de concreto	1	DT2010
EK7651H	Carrito de transporte para tronzadora de concreto	1	DT4000

Accesorios para fumigadora



Tipo	Características / uso recomendado	No. Parte
1	Para los herbicidas de rociadura; también ideal para regar plantas o acondicionar al suelo	6908031000
2	Para hacer niebla que previene la difusión de la medicina	6958011000
3	Para aplicaciones de pesticida en general utilizando insecticidas, fungicidas, etc.	6958025000
4	Fumigador ancho con gran angular.	6949001000
5	Fumigador ancho con gran angular.	6958018000
6	Fumigador en forma circular	6909500100
7	Fumigador en forma circular	6919500000
8	Fumigador conveniente para invernadero por su inyector compacto	6939025000
9	La atomización o chorro se selecciona	6939028000
10	Botella de aceite	0722104800
11	Adaptador "Y" para EVH2000	1955656
12	6909035001 (válvula reguladora) 195565-6 (adaptador "Y") 6949001000 (boquilla de 2 cabezas), 6909039001 (manguera del aspersor) 6919500500 (mango) 6909511500 (tubo del aspersor)	KIT0001

Accesorios para bomba

No incluye bomba, todos los accesorios se venden por separado



Usar en	Descripción	Empaque piezas	No. Parte
EPH1000X	Manguera de salida	1	K000117864
EPH1000X	Manguera de succión	1	K000113837
EPH1000X	Inyector	1	K000115180
EPH1000X	Pichancho	1	K000118193
EPH1000X	Cople	1	K000340781
EPH1000X	Abrazadera	1	K940019032

El equipo estándar (accesorios), las especificaciones y las fotografías pueden variar. Los accesorios pueden no estar incluidos desde origen con las herramientas aunque se indiquen en este catálogo.

Bridas, tuercas y guías



Bridas internas



Bridas externas



Aplicación	Empaque piezas	No. Parte
2708	1	224119-3
3901	1	224280-6
4130	1	224276-7
9049	1	224257-1
9105	1	224047-2
9105	1	224089-6
2414 (antigua)	1	224141-0
2414B (antigua),MT240	1	224385-2
4100C, 4112	1	224184-2
4100NH,4140,4200NH MCC400,MT410	1	224080-4
5007MG/ MGA	1	224151-7
5007NB,5008NB	1	224360-8
5007NB,5008NB	1	224223-8
5008MG, 5007	1	224411-7
5077B/ NB/ 5377MG	1	224268-6
9047, 9049, 9067/ L,9069,9079, 9617,GA7020,GA7021,GA9010C, GA9020,GA9030,GA9040S,MGA700, MGA900,MT901	1	224317-9
9523NB/NB/HN,MGA400, MT951,9560CV	1	224377-1
9551, MGA450, MT952	1	224394-1
9554NB/HN,9557NB/HN/PB,GA4530	1	224399-1
GA7001/ L	1	224111-9
GA9030	1	224083-8
GC5000	1	224207-6
LC1210,LC1230	1	224308-0
LS1016	1	224428-0
LS1020	1	224241-6
LS1216	1	224431-1
LS1440	1	224264-4
MSS700,MT580	1	224395-9
N5900B	1	224303-0
N9503BH	1	224298-7
GS6000	1	224458-1

Aplicación	Empaque piezas	No. Parte
2708	1	224201-8
3901	1	224505-8
4131	1	224366-6
9105	1	224019-7
9105	1	224090-1
9105	1	224501-6
2414 (antigua)	1	224137-1
2702, 2703, 2704	1	224347-0
4100NH, 4140, 4200NH,MCC400, MT410	1	224081-2
5007MG,5008MG,BSS611	1	224409-4
5008MG,5007,BSS611	1	224403-6
5201NA	1	224160-6
5900B	1	224118-5
9000BL	1	224517-1
9005,9015BD,9047,9049,9067L, 9069,9079,9505BH,9524/NB, 9527/NB/PB,9561/C/CV, 9564/C/CV/CVR/PC/PCV, 9617,BGA452,GA4530, G5010,GA7020,GA7021, GA9010,GA9020,GA9030, GA9040S,MGA450,MGA700, MGA900,MT901,MT952	1	224568-4
GA7001/ L	1	224512-1
GA9030	1	224256-3
GB800	1	8003
LC1210,LC1230	1	224309-8
LS1016	1	224429-8
LS1216	1	224432-9
LS1440	1	224310-3
MGA400,MT951	1	224573-1
MLS100	1	JM23000065
MSS700,MT580	1	224396-7
PC1100	1	224526-0
SG1250	1	224577-3
GS6000	1	224467-0

El equipo estándar (accesorios), las especificaciones y las fotografías pueden variar.
Los accesorios pueden no estar incluidos desde origen con las herramientas aunque se indiquen en este catálogo.

Bridas internas externas



Aplicación	Empaque Piezas	No. Parte
LS1030 (antigua)	1	224274-1
2702,2703,LF1000,LH1040F,LS1013,LS1030N,LS1040/F,LS1211,LS1214,LS1220,LS1221	1	224333-1
2702,2703,LF1000,LH1040F,LS1013,LS1030N,LS1040/F,LS1211,LS1214,LS1220,LS1221	1	224355-1
5007NB,NH/NL,5008NB,5037NB,5057NB,5277B/NB,5377MG,5740NB,BSS610,LS0714FL	1	224275-9
2414NB,MLC140,MT240	1	224299-5
GB600,GB601	1	6004

Accesorios para sierras

Guías paralelas



Usar en	Aplicación	Tipo	Empaque Piezas	No. Parte
5008NB	Auxiliar para cortes rectos	Guía paralela	1	164818-4
5037NB,5900B	Auxiliar para cortes rectos	Guía paralela	1	164021-7
5077NB,5740NB	Auxiliar para cortes rectos	Guía paralela	1	164095-8
2704	Con transportador y guía deslizable	Regla guía	1	194241-9
2702,2703	Guía de grados con transportador	Regla guía	1	122555-6
2704,2705	Guía de grados con transportador	Regla guía	1	122735-4
LF1000	Guía de grados con transportador	Regla guía	1	122730-4
LF1000	Guía deslizable	Regla guía	1	122729-9
LH1040F	Guía deslizable	Regla guía	1	122707-9
LH1040F	Guía frontal de aluminio	Regla guía	1	150662-5
LS1220	Guía frontal de aluminio	Regla guía	1	150796-4
LS1016	Guía frontal derecha	Regla guía	1	158969-3
LS1016	Guía frontal izquierda	Regla guía	1	158970-8
LS1016	Kit laser	laser	1	638651-5
2702,2703	Guía para sierras de banco	Regla guía	1	122556-4
2704	Set completo de guía deslizable	Regla guía	1	122740-1
GS6000	Jgo. de cubierta de disco 150K		1	123200-6

Extensiones



Usar en	Aplicación	Tipo	Empaque Piezas	No. Parte
LS1030N,LS1040	Apoyo y nivel para barras de extensión	Base para barras de extensión	1	122446-1
LS1030N,LS1040	Apoyo y nivel para barras de extensión	Base para barras de extensión	1	256812-1
LS1220,LS1221	Apoyo y nivel para barras de extensión	Base para barras de extensión	1	192671-8
LS1214	Aseguramiento de la pieza a cortar	Protección derecha	1	153898-5
LS1221	Aumenta el espacio de trabajo p/ apoyo del material	Extensión 160	1	323726-0
LS1016	Aumenta el espacio de trabajo p/ apoyo del material	Extensión de soporte	1	192501-3
2704	Aumenta el espacio de trabajo p/ apoyo del material	Extensión frontal	1	194087-3
2704	Aumenta el espacio de trabajo p/ apoyo del material	Extensión izquierda	1	194086-5
LS1016	Aumenta el espacio de trabajo p/ apoyo del material	Extensión lateral	1	322932-4
LS1016	Aumenta el espacio de trabajo p/ apoyo del material	Extensión lateral	1	325673-1
LS1030N,LS1040	Aumenta el espacio de trabajo p/ apoyo del material	Extensión lateral	1	322312-4
LS1030N,LS1040	Aumenta el espacio de trabajo p/ apoyo del material	Extensión lateral	1	192118-2
LS1220,LS1221	Aumenta el espacio de trabajo p/ apoyo del material	Extensión lateral	1	192673-4
2702,2703	Aumenta el espacio de trabajo p/ apoyo del material	Mesa complementaria derecha 60x40cm	1	192797-6
2702,2703	Aumenta el espacio de trabajo p/ apoyo del material	Mesa complementaria derecha 60x40cm	1	192798-4



Prensas



Usaren	Aplicación	Tipo	Medidas	Empaque Piezas	No. Parte
LS0714	Asegura el material sobre la herramienta	Prensa horizontal		1	122567-9
LS1016	Asegura el material sobre la herramienta	Prensa horizontal		1	122930-6
LS1030\LS1040, LS1013,LS1220, LS1211	Asegura el material sobre la herramienta	Prensa horizontal	5-1/2"	1	122470-4
LS1030\LS1040, LS1440	Asegura el material sobre la herramienta	Prensa horizontal	7"	1	122625-1
LS0714	Asegura el material sobre la herramienta	Prensa vertical		1	122571-8
LS1016	Asegura el material sobre la herramienta	Prensa vertical		1	122854-6
LS1030\LS1040, LS1013,LS1220	Asegura el material sobre la herramienta	Prensa vertical	2-1/4"	1	122536-0
LS1030\LS1040, LS1013,LS1220	Asegura el material sobre la herramienta	Prensa vertical	2-1/4"	1	192672-6
LS1212/14/F	Asegura el material sobre la herramienta	Prensa vertical		1	122540-9
LS1013	Limita la inclinación de la pieza para uso en corte de molduras	Prensas de inclinación		1	192628-9
LS1045	Limita la inclinación de la pieza para uso en corte de molduras	Prensas de inclinación		1	192622-1
LS1216	Limita la inclinación de la pieza para uso en corte de molduras	Prensas de inclinación		1	195253-5
LS1220	Limita la inclinación de la pieza para uso en corte de molduras	Prensas de inclinación		1	192669-5
	Asegura el material sobre la herramienta	Prensa		1	JM23000182

Estuche de plástico



Usar en	Descripción	Empaque piezas	No. Parte
507NB/MG/MGA/NK	Transportación y protección de la herramienta	1	824772-1

Soportes para sierras



No.	Descripción	Usar en	No. Parte
1	Carro de mano	2702, 2703, 2704	194093-8
2	Mesa de trabajo con ruedas	2704, 2705	JM27000500
3	Mesa de trabajo con ruedas para sierra de banco	MLT100	JM274000300



* Se puede usar en todas las sierras compuestas, sierras de inglete y mesa de banco

Descripción	No. Parte
Mesa de trabajo para sierra de banco	WST05
Mesa de trabajo para sierra de banco, más ligera que la WST05 la herramienta se puede colocar y quitar sin llave	WST06

El equipo estándar (accesorios), las especificaciones y las fotografías pueden variar. Los accesorios pueden no estar incluidos desde origen con las herramientas aunque se indiquen en este catálogo.



Descripción	Para modelo	No. Parte
Mesa de trabajo plegable con extensión	Todas las sierras de inglete compuesto, sierra de inglete	194943-7



Descripción	Para modelo	No. Parte
Soporte plegable para sierras de inglete	Todas las sierras de inglete compuesto, sierra de inglete	194043-3
Soporte plegable	LS0711B,LS0711Z,LS0713/FL,LS0714/F/FL,LS0711D,LS1013/F,LS1030N,LS1040/F,LS1212/F,LS1214/F,LS1220,LS1221,2012NB	194053-0



Usar en	Aplicación	Tipo	No. Parte
LS1220	Adaptación para extracción de polvo	Codo direccional	416368-8
5007NB	Apoyo para cortes más precisos	Mango para sierra circular	419360-3
LS0714	Protección al usuario contra expulsión de residuos	Complemento de guarda protectora	122472-0
2702	Protección al usuario contra expulsión de residuos	Guarda	168313-6



Descripción	Para modelo	No. Parte
Recolector de polvo p/ LS1016 / LS1216	LS1016/ LS1216	194175-6



Guardas, puños y recolectores de polvo



Accesorios para esmeriladoras



Usar en	Aplicación	Medidas	Fijación	Empaque Piezas	No. Parte
9564,9565	Tapa cubre polvo para uso con disco aplanador de concreto	4-1/2"	Anillo con seguro de presión	1	195236-5
9561	Protección para el operador contra despojos	4-1/2"	Anillo con tornillo	1	135107-4
9524,9527,9551 MGA450,MT952	Protección para el operador contra despojos	4-1/2"	Anillo con tornillo	1	165362-4
9524/NB, 9527/NB/PB	Protección para el operador contra despojos	4-1/2"	Anillo con tornillo	1	165053-7
9554, 9557NB	Protección para el operador contra despojos	4-1/2"	Anillo con tornillo	1	125267-0
GA4530	Protección para el operador contra despojos	4-1/2"	Anillo con tornillo	1	135245-2
GA4534	Protección para el operador contra despojos	4-1/2"	Anillo con tornillo	1	122886-3
9501, 9514B	Protección para el operador contra despojos	4-1/2"	Tornillos fijados a cabeza de herramienta	1	342554-4
9565CV, GA5010C	Protección para el operador contra despojos	5"	Anillo con tornillo	1	135108-2
9015DB	Protección para el operador contra despojos	5"	Tornillo (se vende por separado)	1	165055-3
MGA701	Protección para el operador contra despojos	5"	Anillo con tornillo	1	122890-2
9067, 9067L, MGA700	Protección para el operador contra despojos	7"	Anillo con tornillo	1	154768-1
GA7020,GA7021	Protección para el operador contra despojos	7"	Anillo con tornillo	1	154676-6
GA7050R	Protección para el operador contra despojos	7"	Anillo con tornillo	1	122939-8
GA7911	Protección para el operador contra despojos	7"	Anillo con tornillo	1	191395-3
MT900,MGA901	Protección para el operador contra despojos	9"	Anillo con tornillo	1	122892-8
9069,MGA900, MT901	Protección para el operador contra despojos	9"	Tornillo (se vende por separado)	1	154767-3
9079	Protección para el operador contra despojos	9"	Anillo con seguro de presión	1	163424-2
9069	Protección para el operador contra despojos	9"	Anillo con tornillo	1	164879-4
GA9050R	Protección para el operador contra despojos	9"	Anillo con tornillo	1	122938-0

Guarda recolectora de polvo



Usar en	Descripción	No. Parte
Esmeriles de 7"	Guarda extractora de polvo de 7"	195386-6
Todas las esmeriladoras de 4" y 5"	Guarda recolectora de polvo diámetro 125mm	196846-1

Empuñaduras



Usar en	Tipo	Empaque Piezas	No. Parte
Todas las mini esmeriladoras de 4 1/2"	Estándar	1	153489-2
6013BR, 6016,63004, 9005B,9015DB,9218PB /SB,DS4011,DS5000,GA7001/L,GA7911	Estándar	1	152492-0
GA4030	Estándar	1	153504-2
Todas las Esmeriladoras de 7" y 9"	Estándar	1	152539-0
Esmeriladoras GA5010/9020/6020	Anti vibración	1	194514-0
Esmeriladoras GA5010/9020/6020	Anti vibración	1	194543-3
Pulidoras PV7001C,GV7000C GV5010C,GV601	Estándar	1	152491-2
GA5010,CA5011,GA5020,GA5021/C,GA6010,CA6011,GA6020/C,GA6021/C	Agarradera Superior tipo "D"	1	194483-5
Pulidora 9227C	Agarradera Superior tipo "D"	1	416256-9

Base para agarradera lateral



Usar en	Descripción	No. Parte
Base para agarradera lateral	HR4000C,HR4002,HR4510	416299-1

Empuñadura lateral



Usar en	Descripción	No. Parte
HP2010N	Empuñadura lateral	122428-3
HR3200C	Empuñadura lateral	135197-7
HR3540C,HR3541FC, HR4001C, HR4010C, HR4011C,HR4501C, HR4510C,HR4511C	Empuñadura lateral 36	135209-6
HR4003C, HR4013C	Empuñadura lateral	123138-5
HR5202C, HR5212C	Empuñadura lateral	135629-4

ACCESORIOS

Guardas, puños y recolectores de polvo

Empuñadura lateral



Usar en	Descripción	No. Parte
HP1230, HP2032, HP2034, HP2040, HP2042, HP2050, HP2010, HR2431, HR2450	Empuñadura lateral	152521-9

Empuñadura lateral



Usar en	Descripción	No. Parte
HP1230, HO2050/F, HP2051/F, HP2070/F, HP2071/F, HR2010, HR2020, HR2021, HR2022, HR2432, HR2440/F, HR2441, HR2442, HR2445, HR2450/F/T/FT, HR2451, HR2452, HR2453, HR2454, HR2455	Empuñadura lateral	153503-4

Empuñadura lateral con cubierta de neopreno



Usar en	Descripción	No. Parte
BHR202, BHR242, BHR243, BHR261, BHR262, HP1230, HR1830/F/FT, HR2230, HR2460/F, HR2470/F/T/FT, HR2475, HR2800, HR2810/FT, HR2811FT	Empuñadura lateral con cubierta de neopreno	158057-6

Empuñadura lateral



Usar en	Descripción	No. Parte
HM0870C	Empuñadura lateral	158131-0
HR3851, HR3850K, HR5000/K, 8406, 8406C	Empuñadura lateral 32	273472-4

Empuñadura lateral completa



Usar en	Descripción	No. Parte
HM0870C, HM0871C	Empuñadura lateral completa	135332-7

Mango de sujeción



Usar en	Descripción	No. Parte
HR5000	Mango de sujeción completo	134887-9
HM1111C, HR4000C, HR4001C, HR4011C, HR4510C	Mango de sujeción completo	134890-0
HM1100/C, HM1100C, HM1140C, HM1211B	Mango de sujeción completo	134909-5
HM1202/C, HM1203C, HM1213C, HR5201C, HR5210C, HR5211C	Mango de sujeción completo	135269-8

Paño de limpieza



Usar en	Descripción	No. Parte
HR3851	Paño de limpieza	443122-7

El equipo estándar (accesorios), las especificaciones y las fotografías pueden variar. Los accesorios pueden no estar incluidos desde origen con las herramientas aunque se indiquen en este catálogo.

Cubre polvo



Usar en	Descripción	No. Parte
HK1800, HK1810	Cubre polvo	423154-0

Dispositivo recolector de polvo para brocas y cinceles



Usar en	Descripción	No. Parte
HR5202C, HR5212C	Extractor de polvo	196858-4
HR4011C	Extractor de polvo	196074-8

Recolector de polvo



Usar en	Descripción	No. Parte
Martillos rotativos SDS-Plus	Recolector de polvo	195048-6

Dispositivo recolector de polvo para HM1812



*Con manguera

Usar en	Descripción	No. Parte
HM1812	Extractor de polvo	197148-8*
HM1812	Extractor de polvo	197168-2



ACCESORIOS

Guardas, puños y recolectores de polvo

Respaldos, borlas y adaptadores



Usaren	Aplicación	Tipo	Diámetro	Empaque Piezas	No. Parte
	Aumentar diámetro de flecha para uso de cardas con esmeriladoras	Adaptador para cepillo de alambre		1	323015-A
Borla D-57071	Adaptador	Borla de lana	7"	1	D-57087
9227C/B,PV7001/C, PV7000C,SA7000C	Pulido de pinturas y poliéster	Borla de lana	7"	1	192629-7
9227C/B,PV7001/C, PV7000C,SA7000C	Pulido de pinturas y poliéster	Borla de lana	7"	1	743403-A
9227C/B,PV7001/C, PV7000C,SA7000C	Pulido de pinturas y poliéster	Borla Lana con listón	7"	1	P-07381
9227C/B,PV7001/C, PV7000C,SA7000C	Pulido de pinturas y poliéster	Borla Lana con listón	7"	1	D-57071
9227C/B,PV7001/C, PV7000C,SA7000C	Para uso de borla con base de velcro	Respaldo con velcro	7"	1	743052-5
GV6010	Uso de borlas con listón y discos de lija.	Respaldo de goma	4"	1	743036-3
Esmeriles Angulares 4-1/2"	Uso de borlas con listón y discos de lija.	Respaldo de goma	5-1/2"	1	743033-9
PK5001C, PK5011C	Uso de borlas con listón y discos de lija.	Respaldo hule	5"	1	743015-1
GA7001L,GA7911, GV7000C,9067L,9077SL, 9069,92185B,9227C, 9227CY	Uso de borlas con listón y discos de lija.	Respaldo hule	7"	1	192978-2
GV5000	Para uso con discos abrasivos de tipo flexible	Respaldo de plástico	5"	1	743025-8
GA7001L,GA7911, 9067L,9077SL, 9069	Para uso con discos abrasivos de tipo flexible	Respaldo de plástico	7"	1	743027-4

Tubo recolector de polvo



Usar en	Descripción	No. Parte
HR2510	Tubo recolector de polvo	122376-6

Grasa para martillos rotativos



Usar en	Descripción	No. Parte
Todos los modelos	Grasa para martillos (para lubricación de la cámara de compresión)	181490-7

Filtros de protección

Protección de la herramienta contra residuos al interior del motor



Usar en	Fijación	Empaque piezas	No. Parte
9561 /62/63/64/65/66	A presión sobre las rendijas de ventilación	Juego 2 piezas	193903-6
GA7010/9010	A presión sobre las rendijas de ventilación	Juego 2 piezas	193956-5
GA7020/30/40, GA9020/30/40	A presión sobre las rendijas de ventilación	Juego 2 piezas	194289-1
9564PVC,9565PCV, 9566PCV	A presión sobre las rendijas de ventilación	Juego 2 piezas	195446-4
9564CVL,9565CVL, 9565CLR,PW5000C, PW5001C	A presión sobre las rendijas de ventilación	Juego 2 piezas	417322-5



El equipo estándar (accesorios), las especificaciones y las fotografías pueden variar. Los accesorios pueden no estar incluidos desde origen con las herramientas aunque se indiquen en este catálogo.

Mezcladores y boquillas



Mezclador

Accesorios para mezclador

	Usar en	Aplicación	Barra de eje	Tipo	Fabricación	Medidas (diám-eje)	Tornillo	Empaque Pieza	No. Parte
	UT1305 (1300 Rpm)	Mezclas de baja densidad (pinturas vinílicas, esmaltes, solventes)	A43751 acero inoxidable, rosca interna	Disco 130	Acero inoxidable	5" x 1/4"	2652205 M8 x 18	1	A-43670
	UT1305 (1300 Rpm)	Mezclas de baja densidad (pinturas vinílicas, esmaltes, solventes)	A43751 acero inoxidable, rosca interna	Disco 150	Acero inoxidable	6" x 1/4"	2516865 M8 x 25	1	A-43686
	UT1305 (1300 Rpm)	Mezclas de baja densidad (pinturas vinílicas, esmaltes, solventes)	A43751 acero inoxidable, rosca interna	Disco 165	Acero inoxidable	6 x 1/4"	2652205 M8 x 18	1	A-43692
	UT2204 (550 rpm)	Mezclas de alta densidad (pastas texturizadas,yesos, mezclas cementadas)	A43773 acero inoxidable vastago liso	Helice 175	Aluminio	7" x 3/8" Int. Liso	2654752 W5/16 x 16	1	A-43701
	UT2204 (550 rpm)	Mezclas de alta densidad (pastas texturizadas,yesos, mezclas cementadas)	A43773 acero inoxidable vastago liso	Helice 190	Acero tropicalizado	7-1/2" x 3/8" Int. Liso	2654752 W5/16 x 16	1	A-33065
	UT2204 (550 rpm)	Mezclas de alta densidad (pastas texturizadas,yesos, mezclas cementadas)	A43773 acero inoxidable vastago liso	Helice 200	Aluminio	7-3/4" x 3/8" Int. Liso	2654752 W5/16 x 16	1	315113-7
	UT2204 (550 rpm)	Mezclas de alta densidad (pastas texturizadas,yesos, mezclas cementadas)	A43773 acero inoxidable vastago liso	Helice 220	Aluminio	9" x 3/8" Int. Liso	2654401 M8 x 16	1	A-43717
	UT2204 (550 rpm)	Mezclas de alta densidad (pastas texturizadas,yesos, mezclas cementadas)	A43773 acero inoxidable vastago liso	Helice 135	Aluminio	5-1/4" x 3/8" Int. Liso	2654752 W5/16 x 16	1	A-43723
	UT2204 (550 rpm)	Mezclas de alta densidad (pastas texturizadas,yesos, mezclas cementadas)	A43773 acero inoxidable vastago liso	Helice 183	Aluminio	7" x 3/8" Int. Liso	2654752 W5/16 x 16	1	A-43739

El equipo estándar (accesorios), las especificaciones y las fotografías pueden variar.
Los accesorios pueden no estar incluidos desde origen con las herramientas aunque se indiquen en este catálogo.

Mezclador

Accesorios para mezclador

		Aplicación	Barra de eje	Tipo	Fabricación	Medidas (diám-eje)	Tornillo	Empaque Pieza	No. Parte
	UT2204 (550 Rpm)	Mezclas de alta densidad (pastas texturizadas, yesos, mezclas cementadas)	A43773 acero inoxidable vastago liso	Helice 201	Acero tropicalizado	8" x 3/8" Int. liso	2654752 W5/16x16	1	A-33071
	UT2204 (550 Rpm)	Mezclas de alta densidad (pastas texturizadas, yesos, mezclas cementadas)	A43795 acero rosca exterior	Helice 200	Acero tropicalizado	8" x 3/8" Cuerda interna	2654752 W5/16x16	1	A-43745







Ejes para mezclador

Usar en	Fabricación	Medidas (diámetro-eje)	Tornillo	Empaque Pieza	No. Parte
UT1305	Acero inoxidable	3/8" x 23" Rosca interna	Vea especificaciones del acceso mezclador	1	A-43751
UT2204	Acero inoxidable	3/8" x 23" Vastago liso	Vea especificaciones del acceso mezclador	1	A-43773
UT2204	Acero al carbón	3/8" x 21" Rosca exterior	Vea especificaciones del acceso mezclador	1	A-43795



Accesorios para pistolas térmicas

Boquillas

	Tipo	Aplicación	Medidas	Usar en	Empaque Pieza	No. Parte
	Plana	Flujo de aire para calefacción de grandes superficies	3" X 1/4"	HG1100	1	110702-A
	Reducción	Flujo de aire en superficies pequeñas, adaptable con 110720A para soldadura de plástico.	3/8"	HG1100	1	110706-A
	Boquilla Para soldar	Para adaptar con 110720A, flujo concentrado de aire para derretir barras de soldadura plástica o unión de piezas plásticas.	3/4"	HG1100	1	110720-A
	Boquilla deflectora larga	Para deflectar el flujo de aire alrededor de superficies tubulares, para doblar tubo PVC, materiales plásticos, descongelar tuberías y soldar cobre.	3"	HG1100	1	110730-A
	Boquilla deflectora 3/8"	Boquilla deflectora pequeña para activar soldadura, para cables, conectores y manguera termo-retráctil	3/8"	HG1100	1	110746-A
	Boquilla angular	Flujo de aire en superficies angostas, nariz angular para dirección de flujo de aire, para soldar materiales de PVC, lozeta asfaltada en techos, entre otras aplicaciones	1-3/4" x 3/16"	HG1100	1	110751-A
	Boquilla angular	Para estiramiento de papel o plásticos adhesivos, para evitar acumulación de bolsas de aire		HG5002, HG5012	1	P-33679
	Boquilla angular	Boquilla para protección de vidrio		HG5002, HG5012	1	P-71417
	Plana	Para calentamiento de grandes superficies y sellado de micas adhesivas.		HG5002, HG5012	1	P-71423







	Tipo	Aplicación	Medidas	Usar en	Empaque Pieza	No. Parte
	Boquilla deflectora	Para doblar tuberías de PVC o soldadura en tuberías de cobre.		HG5002, HG5012	1	P-71445
	Nariz reductora	Boquilla deflectora pequeña para activar soldadura, para cables conectores y manguera termo-retráctil		HG5002, HG5012	1	P-33691
		Boquilla deflectora pequeña para activar soldadura, para cables conectores y manguera termo-retráctil		HG651C	1	P-71439
	Boquilla para pegado de lona	Para aplicaciones en el manejo de lonas plásticas		HG651C	1	P-71489
	Boquilla reductora para soldar	Flujo de aire en superficies pequeñas, para soldadura de plástico		HG651C	1	P-71451
		Deflector soldador de cubiertas		HG651C	1	P-71495
		Boquilla de sopladora rápida		HG651C	1	P-71473



El equipo estándar (accesorios), las especificaciones y las fotografías pueden variar. Los accesorios pueden no estar incluidos desde origen con las herramientas aunque se indiquen en este catálogo.

Accesorios para pistolas térmicas

Boquillas

	Tipo	Aplicación	Medidas	Usar en	Empaque Pieza	No. Parte		Tipo	Aplicación	Medidas	Usar en	Empaque Pieza	No. Parte
	Soldadura PVC	Para operaciones de soldado y relleno en materiales plásticos. (Asegurese que el tipo de soldadura sea compatible con el material a soldar).	9" x 1/8"	HG1100, HG5002	Bolsa 100gr. (25 Pzs.)	110731-A		Soldadura ABS (Termo plástico)		9" x 1/8"	HG651C	20 Pzs	P-71532
	Soldadura ABS	Para operaciones de soldado y relleno en materiales plásticos. (Asegurese que el tipo de soldadura sea compatible con el material a soldar).	9" x 1/8"	HG1100, HG5002	Bolsa 100gr. (25 Pzs.)	110742-A		Rodillo	Para estiramiento, sellado o parchado de lonas vinílicas y tapices.	1-1/2" Diámetro x 1-1/4" ancho	Todos	1	P-71504
	Soldadura PP (Poli-propileno)		9" x 1/8"	HG651C	20 Pzs	P-71510		Espátula		2"	Todos	1	P-71548
	Soldadura HDPE (Poli-etileno de alta densidad)		9" x 1/8"	HG651C	20 Pzs	P-71526		Juego de espátulas		Triangular plana redonda	Todos	1	P-71554

RECOMENDACIONES DE USO



No use en posición a 90 grados



Use la herramienta inclinada



Coloque la herramienta boca arriba cuando esté en reposo.



Guantes, lentes de seguridad y accesorios para aspiradoras



Equipo de seguridad

Para protección del usuario durante el uso de herramientas

Guantes

	Descripción	Talla	Empaque Pieza	No. Parte
	Guante profesional de carnaza para esmeriladoras	L	Par	988000909
	Guante profesional de carnaza para esmeriladoras	XL	Par	988000910
	Guante profesional de carnaza para esmeriladoras	XXL	Par	988000911
	Guante profesional acabado en piel	Chica	Par	988000807
	Guante profesional acabado en piel	Mediana	Par	988000808
	Guante profesional acabado en piel	Grande	Par	988000809
	Guante profesional acabado en piel	Larga	Par	988000810
	Guante profesional acabado en piel	Extra	Par	988000811
	Guante universal acabado textil	Chica	Par	988000707
	Guante universal acabado textil	Mediana	Par	988000708
	Guante universal acabado textil	Grande	Par	988000709
	Guante universal acabado textil	Larga	Par	988000710
	Guante universal acabado textil	Extra	Par	988000711

Lentes de seguridad

Equipo de seguridad para protección durante el uso de herramientas

	Descripción	Talla	Empaque Pieza	No. Parte
	Lentes de seguridad para protección ocular	Universal	Pieza	T-02456 Humo
	Lentes de seguridad para protección ocular	Universal	Pieza	T-02559 Verde
	Lentes de seguridad para protección ocular	Universal	Pieza	T-02543 Ámbar
	Lentes de seguridad para protección ocular	Universal	Pieza	T-02462 Transparente

Varios

Portaherramientas

Accesibilidad a los equipos de trabajo

	Descripción	Empaque pieza	No. Parte
	Portaherramienta para instaladores c/ porta martillo	1	P-80933
	Portadesarmadores universal Makita	1	P-80868
	Portaherramienta para instaladores c/porta martillo profesional	1	P-81343
	Portadesarmadores c/ porta cinta de aislar profesional	1	P-81337
	Porta clavos c/soporte para martillos	1	P-81480
	Porta pijas c/soporte para martillos profesional	1	P-81371

ACCESORIOS

Guantes, lentes de seguridad y acc p/ aspiradoras

Fundas

Accesibilidad a los equipos de trabajo

	Descripción	Empaque pieza	No. Parte
	Funda de transporte p/guía 194368-5	1	P-67810
	Funda portaherramienta a batería	1	P-80880
	Funda porta smartphone	1	P-80896
	Funda p/ atornillador tipo lápiz para DF010D - TD020D - TD021D	1	P-80999
	Organizador de accesorios c/cordón de seguridad	1	P-80874
	Tirantes de uso pesado usar c/ P-80911	1	P-80612
	Correa azul para hombro y cintura c/ broche	1	P-81000

Cinturones

Accesibilidad a los equipos de trabajo

	Descripción	Empaque pieza	No. Parte
	Cinturón de piel Uso pesado	1	P-71803
	Cinturón para herramientas pesadas	1	P-71819
	Cinturón c/ portapinzas y porta desarmadores plegable	1	P-80905
	Cinturón de uso pesado c/ soporte acojinado usar con P-80612	1	P-80911
	Cinturón c/ fundas (P-80933 / P-80896 P-80880 / P-80911)	1	P-80927
	Cinturón c/ 4 compartimentos profesional	1	P-81474

Cajas para herramientas Makita

	Descripción	Empaque pieza	No. Parte
	Caja de herramientas 16" plástica	1	7167
	Caja de herramientas 20" plástica	1	7165
	Caja de herramientas 24" plástica (cerradura metálica)	1	7685

Maletas Makita para herramientas inalámbricas

	Descripción	Empaque pieza	No. Parte
	Maleta para herramientas inalámbricas	1	831271-6
	Maleta para herramientas inalámbricas color verde	1	831278-2
	Maleta para herramientas inalámbricas color verde con ruedas	1	831279-0
	Maleta para herramientas y accesorios c/ asa	1	P-80949
	Maleta para herramientas y accesorios industrial	1	P-80955
	Maleta para accesorios c/ banco plegable	1	P-80961
	Maleta para herramientas y accesorios c/ cierre	1	P-80977
	Maleta para herramientas y accesorios repelente al agua	1	P-79946

El equipo estándar (accesorios), las especificaciones y las fotografías pueden variar. Los accesorios pueden no estar incluidos desde origen con las herramientas aunque se indiquen en este catálogo.

Accesorios para aspiradoras

Boquillas

	Descripción	Aplicación	Usar en	Empaque Piezas	No. Parte
	Boquilla para pisos 12"	Limpeza de residuos en pisos	407	1	122512-4
	Boquilla para pisos seco mojado	Limpeza de residuos en pisos	VC1310L VC2510L VC3210L VC3211H	1	195551-7
	Boquilla para rincones 33 cm	Limpeza en lugares de difícil acceso	407	1	410306-2
	Boquilla superior	Ensamble	407	1	415965-7
	Boquilla para marcos	Limpeza en lugares de difícil acceso	CL070D CL100D	1	416041-0
	Juego de aspiración	Limpeza en lugares de difícil acceso	UB121D, UB141D, UB181D, BUB142, BUB182	1	191750-9
	Boquilla angosta	Limpeza en lugares de difícil acceso	UB121D, UB141D, UB181D, BUB142, BUB182, BVC340, BVC350, XBV01B	1	192236-6
	Boquilla	Dirección del flujo de aire	UB1101	1	132025-7
	Boquilla	Dirección del flujo de aire	4014NV	1	134182-7
	Boquilla larga	Limpeza de hojarasca	BUB360	1	452123-4

Cepillos

	Descripción	Aplicación	Usar en	Empaque Piezas	No. Parte
	Cepillo largo	Limpeza de alfombras	407	1	743328-0
	Cepillo aspirador	Estanterías	4071D	1	191724-0
	Cepillo aspirador	Limpeza de alfombras	4073D, 4093D	1	122520-5
	Cepillo aspirador	Limpeza de alfombras	BCL140	1	122859-6
	Cepillo aspirador	Limpeza de alfombras	Todas las aspiradoras inalámbricas Makita	1	122291-4
	Cepillo redondo	Limpeza de muebles	Todas las aspiradoras inalámbricas Makita	1	A-37471
	Escobilla redonda	Limpeza de muebles	Varios	1	191657-9

Abrazadera

	Descripción	Aplicación	Usar en	Empaque Piezas	No. Parte
	Abrazadera	Sujeción de manguera	407	1	415964-9



NUEVA LÍNEA de aspiradoras

Aspiradora de mochila
DVC260LZ

Tiempo de trabajo
de 60 minutos en modo alto
con dos baterías BL1850



Aspiradora robótica
DRC200Z

La limpieza automática
Dos modos de funcionamiento
seleccionables: *Modo aleatorio*
y *modo patrón*



Aspiradora híbrida
DVC860Z

Puede utilizar corriente
A/C y D/C
Corriente alterna: 1,050 W
Corriente directa: 36V



ACCESORIOS

Guantes, lentes de seguridad y acc p/ aspiradoras

Tubos y conectores

	Descripción	Aplicación	Usar en	Empaque Piezas	No. Parte
	Broche conector	Para ensamble	407	1	256241-8
	Soportes para manguera	Para ensamble	VC1310L, VC2510L, VC3210L	1	195544-4
	Codo de plástico blanco	Para ensamble	VC1310L, VC2510L, VC3210L	1	154427-7
	Conector frontal 22	Para ensamble	BVC340, BVC350, VC1310L, VC2510L, VC3210	1	195547-8
	Conector frontal 24	Para ensamble	BVC340, BVC350, VC1310L, VC2510L, VC3210	1	195546-0
	Conector frontal 38	Para ensamble	BVC340, BVC350, VC1310L, VC2510L, VC3210	1	195545-2
	Junta 22-38	Para ensamble	VC1310L, VC2510L, VC3210L	1	195548-6
	Ducto conector	Para ensamble	VC1310L, VC2510L, VC3210L	1	415946-1
	Tubo curvo	Para ensamble	VC1310L, VC2510L, VC3210L	1	192562-3
	Tubo recto	Para ensamble	VC1310L, VC2510L, VC3210L	1	192563-1
	Tubo flexible	Para ensamble	Todas las aspiradoras inalámbricas Makita	1	191496-7
	Manguera corrugada	Para ensamble		1	193326-8
	Manguera corrugada 28mm, 3.5m.	Para ensamble	VC1310L, VC2510L, VC3210L	1	195433-3
	Manguera corrugada 28mm, 5m.	Para ensamble	VC1310L, VC2510L, VC3210L	1	195436-7
	Conector	Para ensamble		1	198730-6

Filtros

	Descripción	Aplicación	Usar en	Empaque Piezas	No. Parte
	Pre filtro	Para protección del motor	CL070D, CL100D	1	451208-3
	Filtro de tela para polvo	Para protección del motor	BCL140, BCL180	1	443060-3
	Filtro de papel para polvo	Para protección del motor	BCL182, BCL142, CL102D, CL072D, 4073D, 4093D, 4076D	Paq. 5 piezas	194566-1
	Pre-filtro de tela	Para protección del motor	VC1310L	1	195553-3
	Pre-filtro de tela	Para protección del motor	VC2510L	1	195554-1
	Pre-filtro de tela	Para protección del motor	VC3210L	1	195612-3
	Filtro para polvo	Para protección del motor	VC1310L	1	195438-3
	Filtro para polvo	Para protección del motor	VC2510L	1	195441-4
	Filtro de espuma	Para protección del motor	VC1310L, VC2510L, VC3210L	1	195552-5
	Filtro de tela para agua	Para protección del motor	VC1310L	1	195555-9
	Filtro de tela para agua	Para protección del motor	VC2510L	1	165556-7
	Filtro de tela para agua	Para protección del motor	VC3210L	1	195611-5
	Juego de filtros		DCL182Z	1	198746-1
	Filtro de alto rendimiento		DCL182Z	1	198748-7
	Filtro de alto rendimiento		CL100DZ, DCL180Z, DCL182Z, DCL180Z	1	198752-6

Repuesto para boquilla 12"

	Descripción	Aplicación	Usar en	Empaque Piezas	No. Parte
	Goma para boquilla	Piezas de repuesto	407	1	743327-2
	Rodillo 14mm	Piezas de repuesto	407	1	415962-3
	Rodillo 40	Piezas de repuesto	407	1	151449-8



El equipo estándar (accesorios), las especificaciones y las fotografías pueden variar. Los accesorios pueden no estar incluidos desde origen con las herramientas aunque se indiquen en este catálogo.

Juegos de servicio y carbones

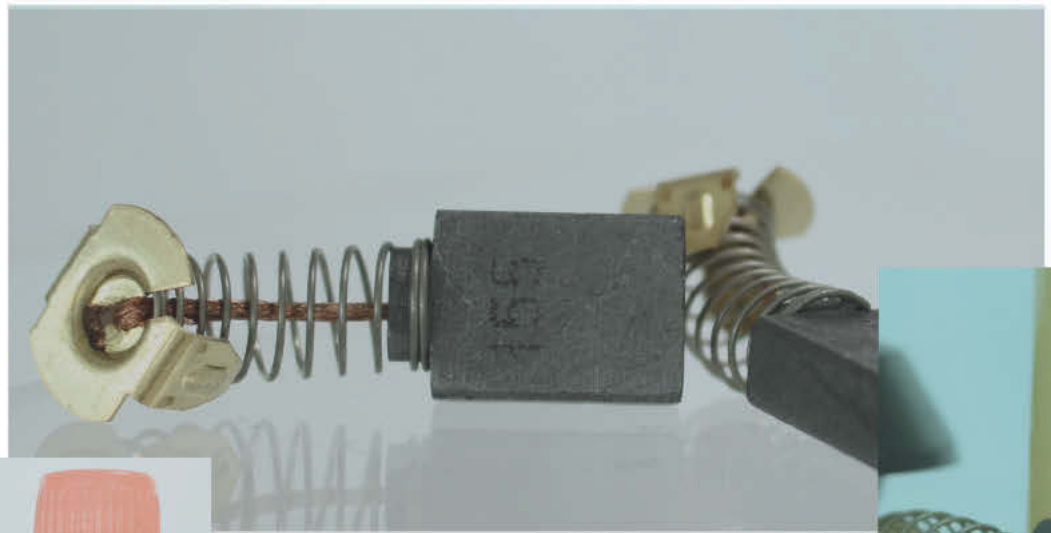

Escobillas de carbón Juego de 2 piezas

CB No.	Para modelo	Tipo	No. Parte
-	G3501R		2097055108
-			181503-4
-	SJ401		375009-000
-	HB500		EIB106C
-	LH1200FL		JM23300083
CB-1	903		194961-5
CB-51	4014N		194963-1
CB-64	6413		194968-1
CB-70	4320, 6501, 9036, 9514B		194970-4
CB-75	3706,4322,4323,4324,4326,4327,4328, 6405 646, 6410, 6413,6510LVR, 6802BV,8416,9035 BO3700, BO3710,BO4510,BO4551,BO4552 BO4562, BO5010, BO5020, BO5021, BO5041 GE0600, GV5000, HP1351,HP1630,JP3000V JV0600,LM2300, LM2850,MBO370,MBO372 MDP200,MDP202, MDP203,MDP300, MDP303 MHP130, MHP131, MHP160,MHP161,MJV430, MT400 MT601, MT650, MT811, MUB101, MUB102		194971-2
CB-76	1900B, 1902, 3700B, 4300BV, 6013BR, 6016, 63004, 6905B 8422B,906H,9803, DA3000R,IN1600, JS1600, JS1660		194972-0
CB-100	4014N		194974-6
CB-105	HK1810,HM0810B, HR2010, HR2511, HR3520	Auto desconexión	194975-4
CB-106	6301, UT0301		194976-2
CB-107	1912B, 3606, 3621,6401,HP2010N, RP0900		194977-0
CB-124	1100, 1600, 2106, 6906, 9005B, 9045B, 9045N, 9207SPB 92185B, 9741,9901,9924DB,IN3200, JS3200, PC1100		194982-7
CB-132	UC3020A, UC3520A, UC4020A		194984-3
CB-153			194985-1
CB-154	1805N, 2012, 2012NB, 2702, 2703, 2704, 3601B, 4110C 5007MG, 5007N, 5007NH, 5007NL, 5008MG, 5012B 5014B, 5037NB,5057KB, 2011NA, 5277B, 5377MG 5477NB, 5900B, 6910, 7104L, 9105, 9401, GA7001 GA7001L, GA7911, GC5000, LF1000, LH1040F, LS1013 LS1016, LS1030N, LS1440, MBS400, MBS401, MT940 NS900B, TW1000		194986-9
CB-155	5007NB, 5008NB, HM1202, HM1202C, HM1211B HR3851, HR5000, HR5001C	Auto desconexión	194987-7
CB-166	407		195057-5
CB-175	HM1111C, HM1203C, HM1213C, HM1307CB, HM1317CB HR4510C, HR5201C, HR5210C, HR5211C		195845-0
CB-203	2414NB, 3612/C, KP312, LC1210, LC1230, LS1211 MLC140, MLC141, MRP100, MRP101, MT240, MT360 RP1800, RP1801F, RP2301FC		194991-6
CB-204	9047, 9049, 9067/L, 9069, 9079, 9079, 9617, GA7020 GA7021, GA7050, GA9010C, GA9020, GA9030, GA9040S GA9050/R, HM1303/B, HM1304/B, HM1500B, HM1800 HM1801, HM1810, MGA700, MGA701, MGA900 MGA901, MT901, PK5011C, SA7000, SA7000C	Auto desconexión	194992-4
CB-210	4112H		194993-2
CB-253	GA5021, PC5000C, PC5001C, SC161		194547-5
CB-303	2107F, 4100NH, 4100NS, 4130, 4131, 4140, 4200NH 5740NB, 6924N, 9015DB, 9227C, 9403, 9404, 9902 9903, 9920, 9921, DA4000LR,DA4031, GA5010, GV7000 JR3030, JR3050T, JR3060T		194996-6
CB-304	HM0860C, HM1100/C, HM1140C, HR3000C, HR4000C	Auto desconexión	194997-4
CB-318	9561/C/CV, 9564/C/CV/CVR/PC/PCV, BO6040, GD0800C GD0810C, PW5001C, SA5040C, SG1250	Auto desconexión	196454-8
CB-325	9554HN/NB, 9557HN/HP/NB/PB, 9564H, GA5040 GD0600,HR2230, HR2300, GA5040, GD0600, HR2230 HR2300,HR2460, HR2470, HR2600, HR2610, HR1810/T		195001-2
CB-327	HR3000C (220V)	220V Auto desconexión	194285-9

CB No.	Para modelo	Tipo	No. Parte
CB-350	HM0870C, HM0871C,HR3200C, HR3210C,HR3540C HR4001C, HR4002, HR4011C	Auto desconexión	195004-6
CB-401	6302/H, 6303/H, 6402, 6820V, 6904VH 6905H, HP1030, HP1310		195005-4
CB-407	4304, 4305, 4340FCT, 4350FCT, 4350T, 6407, 6408, 6807 6821, 6824N, 6825, 6826, 6827, 8450, 9046, BO4556 BO4557, BO4558, BO4900/V, BO5030, BO6030, DA3010F DP3002, DP3003, DP4000, DP4001, DP4002, DP4003 DP4011, FS2500, FS2700, FS2701, FS4200, FS6300 HP1230, HP1500, HP1510, HP1620, HP1640, HP2030 HP2032, HP2034, HP2040, HP2042, HP2050, HP2070 HR2420, HR2431, HR2440, HR2450, SJ1300, SJ8000 MBO450, MBO451, MBO500, MT920, TD0100, UH4261 UH4261, UH5570		195007-0
CB-408	3707FC, 3709, 3901, 6832, 6834, 6846, 6922NB, 6951 6953, 9031,9032, 9500N, 9501B, 9505BH, 9523NBH 9524, 9524NB, 9527, 9527PB, 9551, 9911, DS4010 DS4011, DS5000, JN1601, KP0800, MGA400 MGA450, MGA452, MGD100, MGD101, MKP080 MKP082, MT370, MT910, MT951, MT952, MTR100 RT0700C, TD0101F, TW0200, TW0350		195008-8
CB-415		220 V	195012-7
CB-416	HR2400		191954-3
CB-424	6503D, 6914D		195017-7
CB-430	6213D, 6233D, 6313D, 6317D, 6319D, 6333D, 6337D 6339D, 6343D, 6347D, 6349D, 8413D, 8414D, 8433D 8434D, 8443D, 8444D, BDF460, BGA452, BHR200, BHR240 BJS161, BPB180, BUC122, LXD001, LXJP02, UB3600		195018-5
CB-434	6916FD, 6918D, 6932FD, 6935FD, 6936FD, 6980FD, BFL080F BFL081F, BFL120F, BFL121F, BFL200F, BFT020F, BFT040F		195020-8
CB-440	BDF440, BDF441, BDF451, BDF452, BDF440, BHP441 BHP450, BHP451, BHP452, BTD130F, BTD140, BTD141 BTD142, BTP140, BTW251, BTW253, LXDT04, LXF001 LXPH01, LXPH02, LXSF01		195021-6
CB-441	BHR202, BJR181, BSS610, BSS611 BTD200, BTW450, LXPK01, LXSL01		195022-4
CB-442	BHR261, BUC250, BUH550, UC250D, UH550D, UH650D		195023-2
CB-452	6952		195024-0
CB-458	GA4530, GA4534, MHR200, PJ7000		195025-8

Juegos de servicio

Modelo	Tipo	No. Parte
HM0860C	-	195204-8
HM0870C, HM0871C	-	195113-1
HM1100 / C	-	193243-2
HM1200 / B	-	193244-0
HM1202 / C	-	193391-7
HM1203C, HM1205C, HM1213C, HM1214C	-	195114-9
HM1303 / B	-	193393-3
HM1304 / B	-	195201-4
HM1307C, HM1307CB, HM1317C, HM1317CB	-	195103-4
HM1800	-	193402-8
HM1801, HM1810	-	195205-6
HR1830 / F	-	195198-7
HR2010	B	193396-7
HR2020, HR2021, HR2022, HR2440, HR2441 HR2442, HR2445,HR2450/F/FT/T, HR2451	-	193606-2
HR2800, HR2810/T, HR2811F/FT	-	195206-4
HR2230, HR2460/F, HR2470/F/FT/T	-	195263-2
HR3000C	-	193390-9
HR3200C, HR3210C, HR3210FCT	-	195199-5
HR3540C, HR3541FC	-	195192-9
HR3850/B, HR3851	-	193281-4
HR4000C	-	193283-0
HR4001C, HR4002, HR4010C, HR4011C	-	195195-3
HR5001C	-	193392-5
HR5201C, HR5210C, HR5211C	-	195191-1
HM0830	-	185200-6
HR5202C, HR5212C	-	196865-7
MHM080	-	196918-2

El equipo estándar (accesorios), las especificaciones y las fotografías pueden variar.
Los accesorios pueden no estar incluidos desde origen con las herramientas aunque se indiquen en este catálogo.

TECNOLOGÍAS

Makita ofrece tecnologías pensadas en proporcionar seguridad y comodidad al usuario, así como larga vida y mayor rendimiento de las herramientas.



BL
MOTOR

Alto rendimiento de motores de corriente continua y sin carbones

- Motor libre de mantenimiento debido a que la producción de energía es sin carbones, además de ser más eficiente ya que produce menos fricción y calor que los motores de corriente continua.
- Mayor cantidad de trabajo con una sola carga de batería, ya que la producción de energía es más eficiente, pues su campo de energía es continuo.



LXT
LITHIUM-ION

Tecnología extrema de Litio-ion

- Las herramientas con tecnología Litio-ion utilizan baterías con un sistema de refrigeración que no permite el calentamiento de la batería, además de proveer una carga rápida. (el tiempo de carga varía según el amperaje de la batería)
- Sistema de carga inteligente, la carga y descarga se hace completa, aumentando la vida útil de la batería, además de que el proceso de carga controla la corriente, el voltaje y la temperatura.



XPT
EXTREME PROTECTION TECHNOLOGY

Tecnología de protección extrema

- Esta tecnología provee protección contra polvo y gotas de agua al trabajar con ella en el exterior
- Esta protección no es válida para que la máquina sea sumergida, sino que evita la entrada de agua de lluvia.
- Las aberturas de la ventilación, cuentan con sellos de goma que bloquean la entrada de residuos, protegiendo los componentes eléctricos de la herramienta, además de alargar la vida útil de la herramienta.



ADT
Tecnología de torque automático

Tecnología de torque automático

- En trabajo ligero, la herramienta trabaja en modo de alta velocidad, en trabajos más pesados la herramienta cambia automáticamente a modo de alto torque.
- Facilita las operaciones de uso más continuo o prolongado.



AFT
Tecnología que detecta la retroalimentación

Función inteligente para minimizar el daño por Kick-back

- Si la velocidad baja repentinamente por causa de un atascamiento accidental o intencional del disco, la función AFT apaga la herramienta para proteger al usuario.
- Esta función no previene el atascamiento, pero sí ayuda a evitar accidentes.



CXT
Tecnología Compacta eXtrema

Tecnología compacta extrema

- Nueva línea de cargadores y baterías de 12V CXT de tamaño compacto, ligeras y con terminal deslizable multi-contacto.
- Cuenta con un sistema reforzado de refrigeración que funciona con un ventilador y protege a la batería.
- Cuentan con un indicador de la carga de la batería, son compactas y su tiempo de carga varía de acuerdo al amperaje de la batería (utilizando un cargador rápido DC10SB)



AWS
Sistema de Auto-Encendido Inalámbrico

Tecnología sistema de auto encendido inalámbrico

- Sistema para conectar una herramienta inalámbrica con otra por medio de Bluetooth, de esta manera la segunda se activará al empezar a trabajar con la primera. La función de activación inalámbrica permite una operación cómoda. Conectando una herramienta soportada a la aspiradora, puede limpiar automáticamente, al encender la herramienta, se enciende automáticamente la aspiradora.





AVT

TECNOLOGÍA ANTI VIBRACION

Tecnología ANTI-VIBRACIÓN (bajo carga)

- Absorción dinámica de la vibración, asegura una operación con baja vibración.
- El diseño del cuerpo de la herramienta permite un mejor manejo gracias a sus lados planos.
- Al trabajar con la herramienta por largos periodos el sistema AVT evita una mayor fatiga al usuario.



SOFT NO LOAD

Tecnología de supresión de la velocidad (durante la descarga)

- Reduce automáticamente la vibración de la herramienta cuando no hay carga de trabajo, disminuye la cantidad de vibración en las manos del usuario durante la operación de la herramienta.
- Minimiza la desviación del cincel cuando se coloca en el punto exacto a romper.



DXT

Tecnología de corte exacto y profundo

- Profundidad de corte: unidad de reducción de engranes 3 pasos y guarda posterior retráctil.
- Provee larga capacidad de corte en moldura corona y moldura base.
- Exactitud de corte: doble mecanismo de deslizamiento, uso de 4 rieles de acero cortos libre de vibración con corte exacto y preciso, además de un diseño compacto de la herramienta.



SJS

SUPER JOINT SYSTEM

Super Joint System

- El muelle actúa como un embrague mecánico, evitando daños en los engranajes y posibles riesgos.
- Supresión de las sacudidas por bloqueos accidentales del disco durante el trabajo.
- Cuando se queda bloqueado el disco el usuario recibe una sacudida que puede resultar peligrosa ya que la máquina realiza un pequeño rebote.



SJST

SUPER JOINT SYSTEM

Tecnología para suprimir la vibración hacia el usuario

- Sistema que disminuye la vibración originada desde el disco de desbaste, ya que cuenta con un muelle que absorbe la vibración.
- Al reducir la vibración que llega al usuario, hace más cómoda su operación y con menos fatiga.



TECNOLOGÍA ANTI-RESTART

Tecnología Anti-Restart

- Previene el encendido accidental, evita que en un corte repentino de energía eléctrica la herramienta se ponga en marcha aún cuando el interruptor esté en posición de encendido.
- Tiene una luz LED que al ponerse en rojo indique que la herramienta está engatillada y la tecnología anti-restart está activada; al desengatillar la luz LED se pone en verde indicando que está lista para seguir trabajando.



MM4

MAKITA MOTOR DE 4 TIEMPOS

Motores de 4 tiempos Makita

- Alto desempeño, compacto y ligero.
- Baja emisión de contaminantes.
- Fácil operación y bajo costo de mantenimiento.
- No requiere de mezcla y bajo nivel de ruido.



CENTROS DE SERVICIO DE FÁBRICA
MAKITA MÉXICO CIUDAD DE MÉXICO (D.F.)

NORTE 35 # 780 C
COL. IND. VALLEJO C.P. 02300
MÉXICO, D.F.
TEL: (0155) 53 68 11 05
FAX: (0155) 55 67 33 87 TALLER EXT 110
CONMUTADOR EXT 101
E-MAIL: serviciodf@makita.com.mx

MAKITA GUADALAJARA

AV. SIERRA MAZAMITLA # 5864
COL. PINAR DE LA CALMA REFORMA C.P. 45080
ZAPOPAN, JALISCO
TEL: (01333) 632 80 32 / 36 32 80 57
E-MAIL: serviciogdl@makita.com.mx

MAKITA MONTERREY

AV. PABLO LIVAS # 4207
COL. GUADALUPE VICTORIA C.P. 67180
GUADALUPE, NUEVO LEÓN
TEL: (01818) 372 42 05 / 372 41 93
E-MAIL: serviciomty@makita.com.mx

MAKITA QUERÉTARO

CALLE AV. DEL PARQUE # 1024
COL. VISTA ALEGRE C.P. 76074
QUERÉTARO, QUERÉTARO
TEL: (01442) 222 68 24 / 222 91 70
E-MAIL: serviciopro@makita.com.mx

CENTROS DE SERVICIO AUTORIZADOS MAKITA
AGUASCALIENTES
GRUPO MULTIHERRAMIENTAS

AV. HÉROE DE NACOZARI NORTE # 1116 A
COL. GREMIAL C.P. 20030
AGUASCALIENTES, AGUASCALIENTES
TEL: (01449) 916 11 27 / 916 45 49
E-MAIL: multiherramientas@prodigy.net.mx

HERRAMIENTAS LEO S.A. DE C.V.

IGNACIO ZARAGOZA # 1105
COL. FRACC. EL SOL C.P. 20030
AGUASCALIENTES, AGUASCALIENTES
TEL: (01449) 146 41 81 / 146 41 80
E-MAIL: herramientas53@hotmail.com

BAJA CALIFORNIA NORTE
TJUANA
COMERCIAL DE ACEROS Y PERFILES
FRONTERA S.A. DE C.V.

BLVD. CUCAPAH # 20498
COL. BUENOS AIRES SUR C.P. 22207
TJUANA, B.C.N.
TEL: (01664) 661 05 67 / 629 58 28 Ext. Taller 106
E-MAIL: daniela.moroyoti@acerosfrinter.com

OXIGENOS Y EQUIPOS S.A.

BLVD. AGUA CALIENTE # 1630
COL. FRACC. NEIDHART C.P. 22420
TJUANA, B.C.N.
TEL: (01664) 686 12 11 / 686 13 61
E-MAIL: recepcion@oasatjuana.com

MEXICALI
CONADYSER SC DE RL DE CV

BLVD LAZARO CARDENAS 1651 LOCAL14
COL. DESARROLLO URBANO ZACATECAS
C.P. 21389, B.C.N.
TEL: (01686) 561 87 99
E-MAIL: conadyser@yahoo.com.mx
conadyser1@gmail.com

CORPORATIVO VYK S.C. DE R.L. DE C.V.

BLVD. LAZARO CARDENAS # 1017
COL. INDEPENDENCIA C.P. 21290
MEXICALI, B.C.N.
TEL: (01686) 564 93 30 al 33
E-MAIL: ccordova@vykherramientas.com
vykherramientas@hotmail.com

HERRAMIENTAS IND. Y DOMÉSTICAS S.A. DE C.V

RIO SABINAS # 305 ESQ. CALLE SEXTA
COL. GONZALEZ ORTEGA C.P. 21396
MEXICALI, B.C.N.
TEL: (01686) 580 24 69 / 562 60 84
E-MAIL: oasapalaco@hotmail.com

OASA MEXICALI

BLVD. ADOLFO LOPEZ MATEOS # 850
COL. BELLAVISTA C.P. 21150
MEXICALI, B.C.N.
TEL: (01686) 551 62 00 / 551 62 12 Taller: 551 62 12
E-MAIL: clientes@oasa.com.mx

ENSENADA
AGENCIA ARJONA S.A. DE C.V.

BLVD. TENIENTE AZUETA # 106
COL. RECINTO PORTUARIO C.P. 22800
ENSENADA, B.C.N.
TEL: (01646) 178 31 01
E-MAIL: ventas.ensenada@agenciaarjona.com.mx
mayoreo@agenciaarjona.com.mx

EQUIPOS Y SOLDADURAS DEL NORTE S.A. DE C.V.

AV. JUÁREZ # 1519 ESQ. GUADALUPE
COL. OBRERA C.P. 22830
ENSENADA, B.C.N.
TEL: (01646) 177 00 10 / 176 47 20
FAX: (01646) 177 18 18
E-MAIL: davidsotoens@hotmail.com

BAJA CALIFORNIA SUR
LA PAZ
EQUIPOS Y REMOLQUES DE LA PAZ

BLVD. EUSEBIO KINO # 1825
ENTRE BRAVO Y OCAMPO COL. GUERRERO
C.P. 23020LA PAZ, B.C.S.
TEL: (01612) 185 28 40
Nextel: 612 179 02 96 ID: 92*15*26205*
E-MAIL: equiposyremolquesdelapaz@gmail.com

SAN JOSÉ DEL CABO
CONSTRU RENTAS

CARR. FEDERAL LIBRE TRANSPENINSULAR
SAN JOSÉ-SAN LUCAS MARGEN IZQ. #3015 S/N
COL. LOMAS DE GUAYMITAS, C.P.23445
SAN JOSÉ DEL CABO, B.C.S.
TEL: (01624) 12 46 55
E-MAIL: construrentas_baja@hotmail.com

MG2 S DE R.L. DE C.V.

CARR. FEDERAL LIBRE TRANSPENINSULAR SAN JOSÉ -
SAN LUCAS KM 38.5 COL. ZACATAL
SAN JOSÉ DEL CABO, B.C.S. C.P. 23427
CEL: (624) 157-3761
OFICINA TODOS SANTOS: (612) 145-1043
OFICINA LOS CABOS: (624) 12 013 26
E-MAIL: patriciacovarrubias@live.com.mx

MULTIRRENTAS DEL PACIFICO S. DE R.L. DE C.V
SUCURSAL SAN JOSÉ DEL CABO

VALERIO GONZÁLEZ # 1
COL. PRIMERO DE MAYO C.P. 23400
SAN JOSÉ DEL CABO, B.C.S.
TEL: (01624) 143 45 55
E-MAIL: ventas@multirentas.com.mx

CABO SAN LUCAS
CONSTRU CENTRO

CAMBERO JACOBO ENRIQUE ALBERTO
COL. EL ARENA C.P. 23460
CABO SAN LUCAS, B.C.S.
TEL: (01624) 143 49 84 / 143 49 89
E-MAIL: admon@constru-centro.com.mx

MULTIRRENTAS DEL PACIFICO S. DE R.L. DE C.V "SUCURSAL CABO SAN LUCAS"

ABASOLO Y DIAGONAL MORELOS
COL. EJIDAL C.P. 23410
CABO SAN LUCAS, B.C.S.
TEL: (01624) 143 54 14
E-MAIL: ventascsl@multirentas.com.mx

SCF CRUZ

EJIDO S/N ENTRE CALLE LÓPEZ MATEOS
Y LUIS CORTINEZ COL. ARENAL C.P. 22106
CABO SAN LUCAS B.C.S.
TEL: (01624) 143 52 80
E-MAIL: salvador.cdr@live.com

DE TODOS LOS SANTOS
MG2, S. DE R.L. DE C.V.

CALLE RANGEL ENTRE MORELOS Y MARQUEZ DE LEON
COL. CENTRO, C.P.23300
TODOS LOS SANTOS, B.C.S.
TEL: (01612) 145 10 43
E-MAIL: patriciacovarrubias@live.com.mx

CAMPECHE
C.D. DEL CARMEN
FERREVITOLIN

AV. JUÁREZ # 218 ESQ. CON 35-A
COL. FATIMA C.P. 24110
C.D. DEL CARMEN, CAMPECHE
TEL: (01938) 382 57 70
E-MAIL: vitolin22@hotmail.com

CAMPECHE
COMERCIALIZADORA CEYMON

AZTECA # 5 ENTRE ECUADOR Y SAN DIEGO
COL. TOMÁS ASNAR C.P. 24080
CAMPECHE, CAMPECHE
TEL: (01981) 146 23 03
E-MAIL: makitacamp@outlook.com

CHIAPAS
TUXTLA GUTIÉRREZ
HERRAJES FINOS COPICO

AV. 9a SUR ORIENTE Y 5a ORIENTE # 590-A
COL. OBRERA C.P. 29000
TUXTLA GUTIÉRREZ, CHIAPAS
TEL: (01961) 613 85 86 / 614 73 29
E-MAIL: centroservicio@hfcopico.com

FERRETERA MANDIOLA

5a. NORTE ORIENTE # 245
COL. BARRIO SAN JACINTO C.P. 29000
TUXTLA GUTIÉRREZ, CHIAPAS
TEL: (01961) 613 89 20 / 613 89 21
E-MAIL: oriente@mandiola.com.mx

CENTRO DE SERVICIO DEL SURESTE

AV. 9 SUR ORIENTE # 3510 D
COL. COLONIAL C.P. 29066
TUXTLA GUTIÉRREZ, CHIAPAS
TEL: (01961) 22 32 271 / 22 32 350
E-MAIL: serviciodelsureste@live.com.mx

SAN CRISTÓBAL DE LAS CASAS
FERRETERA CASUA

CALLE COSTA RICA # 16
COL. CENTRO ZONA MERCADO C.P. 29240
SAN CRISTÓBAL DE LAS CASAS, CHIAPAS
TEL: (01967) 678 62 83 / 678 25 41
E-MAIL: cp_jcam@hotmail.com



CENTROS DE SERVICIO AUTORIZADO MAKITA



COMITÁN DE DOMÍNGUEZ

**TORNILLOS Y HERRAMIENTAS PINEDA
SUCURSAL COMITÁN DE DOMÍNGUEZ**
4 A. AVENIDA PONIENTE SUR LOCAL 4
ENTRE 14 SUR PONIENTE
COL. BELISARIO DOMÍNGUEZ C.P. 30400
COMITÁN DE DOMÍNGUEZ, CHIAPAS
TEL: (01963) 10 13 801
E-MAIL: cruz.refacciones@gmail.com

TAPACHULA

**TORNILLOS Y HERRAMIENTAS PINEDA
SUCURSAL TAPACHULA**
17 PONIENTE # 20-A ENTRE 4A Y 6A NORTE
COL CENTRO C.P. 30700
TAPACHULA, CHIAPAS
TEL: (01962) 626 28 07
E-MAIL: mario16416@gmail.com

MADERERIA LOS PINOS

1BOULEVARD FERROCARRIL # 10
COL VILLA LAS FLORES C.P. 30795
TAPACHULA, CHIAPAS
TEL: (01962) 626 21 27
E-MAIL: lopezvictor@live.com.mx

CHIHUAHUA

CHIHUAHUA

**MULTIHERRAMIENTAS Y SERVICIOS DE
CHIHUAHUA**
AV. 20 DE NOVIEMBRE # 2407
COL. PACIFICO C.P. 31030
CHIHUAHUA, CHIHUAHUA
TEL: (01614) 415 93 17 / 415 00 04
E-MAIL: makita_chihuahua@hotmail.com

MULTIHERRAMIENTAS Y SERVICIOS DEL NORTE

AV. TECNOLÓGICO # 11302-A
COL. REVOLUCIÓN C.P. 31135
CHIHUAHUA, CHIHUAHUA
TEL: (01614) 440 10 22 / 296 57 64
E-MAIL: daniel.makita@hotmail.com

SOLUCIONES INDUSTRIALES JR

H. COLEGIO MILITAR # 4307-A
COL. NOMBRE DE DIOS C.P. 31110
CHIHUAHUA, CHIHUAHUA
TEL: (01614) 341 03 14 / 341 03 15
E-MAIL: solucionesindustriales.ch@gmail.com

C.D. CUAUHEMOC

MOTOPARTES EL CORREDOR
CAMPO 12 KM 32 CARRETERA
CUAUHEMOC ALVARO OBREGÓN
COL. MANITOBA C.P. 31500
CD. CUAUHEMOC, CHIHUAHUA
TEL: (01625) 578 62 22 (23 y 21)
E-MAIL: motopartes_13@hotmail.com

CAMARGO

TORQUE MAQUINAS
AV. DIV. DEL NORTE # 707
COL. REVOLUCIÓN C.P. 33740
CAMARGO, CHIHUAHUA
TEL: (01648) 462 41 56
E-MAIL: elalomak@hotmail.com

HIDALGO DEL PARRAL

FERRERERIA REGIONAL DEL PARRAL
AV. NIÑOS HEROES KM 2.4
COL. ALMANCEÑA C.P. 33825
CD. HIDALGO DEL PARRAL, CHIHUAHUA.
TEL: (01627) 527 09 50 / 527 09 51 / 527 09 52
E-MAIL: ferrepasa2@prodigy.net.mx

CD. DELICIAS

PROINSA GAS
AV. 4A SUR # 2604
COL. TIERRA Y LIBERTAD C.P. 33088
CD. DELICIAS, CHIHUAHUA
TEL: (01639) 470 19 14
E-MAIL: proinsa_gas@yahoo.com.mx

CD. JUÁREZ

OXIGENO SOLDADURAS DE JUÁREZ
BLVD. OSCAR FLORES # 2695
COL. FRACC. DIVISIÓN DEL NORTE C.P. 32688
CD. JUÁREZ, CHIHUAHUA
TEL: (01656) 610 61 89 / 610 61 04
E-MAIL: oasajz@prodigy.net.mx

GARLE

RAMÓN RAYÓN #802,
COL. NUEVA ZARAGOZA C.P. 32000
CD. JUÁREZ, CHIHUAHUA
TEL: (01656) 624 75 25 / 640 43 04
E-MAIL: humbretoguitierrez@garle.com.mx

COAHUILA

SALTILLO

CENTRO DE HERRAMIENTAS SALINAS
FRANCISCO COSS # 592 ESQ. ARTEAGA
COL. CENTRO C.P. 25000
SALTILLO, COAHUILA
TEL: (01844) 412 15 55
E-MAIL: makitasaltillo@hotmail.com

LAGACERO GROUP

AV. ALLENDE # 929 NTE.
COL. CENTRO C.P. 25000
SALTILLO, COAHUILA
TEL: (01844) 416 52 66 / 415 60 62 / 416 66 55
E-MAIL: conraloria@lagacero.com

MONCLOVA

**VGM SUMINISTROS INDUSTRIALES,
S.A. DE C.V.**
CUAUHEMOC # 1406 ESQ. CON CHARCO AZUL
COL. EL PUEBLO C.P. 25730
MONCLOVA, COAHUILA
TEL: (01866) 633 00 44
E-MAIL: vgmsumind@prodigy.net
vgmmedmundo@hotmail.com

TORREÓN

MINOTAURO
BLVD. INDEPENDENCIA #76 ORIENTE
COL. CENTRO C.P. 27000
TORREÓN, COAHUILA
TEL: (01871) 718 70 80 / 718 72 72
E-MAIL: tallermatriz@minotauroherramientas.com
ventasmatriz@minotauroherramientas.com

CIA MERCANTIL FERRETERA SA DE CV

PRESIDENTE CARRANZA # 3961
COL. SAN MARCOS. CP 27040,
TORREÓN, COAHUILA
TEL: (01871) 713 34 52 Ext. Taller 232 y Gerencia 229
E-MAIL: taller.servicio@mercantilferreteria.com

LAGACERO GROUP

CALZ. CUAUHEMOC # 965 NTE.
COL. CENTRO C.P. 27000
TORREÓN, COAHUILA
TEL: (01871) 713 72 12 / 713 35 03
E-MAIL: servicios@lagacero.com

CD. ACUÑA

**ACUÑA REFACCIONES
Y ELECTROMECAÁNICA S.A. DE C.V.**
LIBRAMIENTO EMILIO MENDOZA CISNEROS # 295
COL. TIERRA Y LIBERTAD C.P. 26237
CD. ACUÑA, COAHUILA
TEL: (01 877) 772 51 96
E-MAIL: mesaacuna@prodigy.net.mx

COLIMA

LA CUADRA DE LA HERRAMIENTA

FILOMENO MEDINA # 125
COL. CENTRO C.P. 28000
COLIMA, COLIMA
TEL: (01312) 312 41 13
E-MAIL: makitacolima@hotmail.com

EQUIPO Y HERRAMIENTAS DEL PACIFICO

BLVD. MIGUEL DE LA MADRID # 1780
COL. ABELARDO L. RODRIGUEZ C.P. 28863
MANZANILLO, COLIMA
TEL: (01314) 145 23 58
E-MAIL: makita.manzanillo@gmail.com

CIUDAD DE MÉXICO (D.F.)

ELECTRO TÉCNICA EN HERRAMIENTAS

AV. LEÓN DE LOS ALDAMA # 315
COL. SAN FELIPE DE JESUS C.P. 07510
DEL. GUSTAVO A. MADERO, CIUDAD DE MÉXICO
TEL: (0155) 27 33 05 70
E-MAIL: electrotecnicaenherramientas@outlook.com

CASA IKEDA

AV. OBSERVATORIO # 238
COL. DANIEL GARZA C.P. 11830
DEL. MIGUEL HIDALGO CIUDAD DE MÉXICO
TEL: (0155) 52 71 19 10
FAX: (0155) 52 72 45 77
E-MAIL: casaikedaventas@hotmail.com

FERRELLYR

ARTICULO 123 # 72 A
COL. CENTRO C.P. 06050
DEL. CUAUHEMOC, CIUDAD DE MÉXICO
TEL: (0155) 55 18 59 60 Ext. 113 Y 114
E-MAIL: ferrellymakitamaster@hotmail.com

HERRAMIENTAS Y SERVICIOS PROFESIONALES, S.A. DE C.V.

CORREGIDORA # 38 LOCAL 201-202
COL. CENTRO C.P. 06050
ÁREA 5, CIUDAD DE MÉXICO
TEL: (0155) 55 42 41 85 / 55 42 40 24
E-MAIL: hyspcentro@hotmail.com

GENERAL EN HERRAMIENTAS

AV. FRANCISCO MORAZAN # 442 B Y C
COL. PUEBLA C.P. 15020
DEL. IZTACALCO, CIUDAD DE MÉXICO
TEL: (0155) 57 00 57 90 / 57 00 34 95
E-MAIL: ghs@prodigy.net.mx

HERRAMIENTAS ELÉCTRICAS ZARAGOZA

CALZ. IGNACIO ZARAGOZA MZ. 108 LT. 904
COL. SANTA MARTHA ACATITLA C.P. 09510
DEL. IZTAPALAPA, CIUDAD DE MÉXICO
TEL: (0155) 54 41 95 96 / 22 37 18 63
E-MAIL: herramientaszaragoza@hotmail.com

HERRAMIENTAS COPER

CARRETERA MÉXICO TOLUCA # 3100 KM 20.5
COL. CUAJIMALPA C.P. 5000
DEL. CUAJIMALPA, CIUDAD DE MÉXICO
TEL: (0155) 21 63 27 68 / 81 64 65 99
E-MAIL: ppedu@hotmail.com

HERRAMIENTAS REFACCIONES Y SERVICIOS

CALLE 19 # 64 A
COL. PROHOGAR C.P. 02600
DEL. AZCAPOTZALCO, CIUDAD DE MÉXICO
TEL: (0155) 53 55 67 78 / 55 56 12 42
FAX: 55 56 94 34
E-MAIL: cristine_b@hotmail.com

TPS TECNO SERVICIOS PROFESIONALES

AV. LUIS SPOTA # 125-3
COL. INDEPENDENCIA C.P. 03630
DEL IZTAPALAPA, CIUDAD DE MÉXICO
TEL: (0155) 56 72 58 47
E-MAIL: tecnopablo2@hotmail.com

ABRASIVOS Y HERRAMIENTAS ZAMORANO

AV. PLUTARCO ELIAS CALLES # 1331
COL. NATIVITAS C.P. 03500
DEL BENITO JUÁREZ, CIUDAD DE MÉXICO
TEL: (0155) 55 39 39 96 / 55 32 07 43
E-MAIL: ventas@zamorano.mx

PEDRO BALDOVINOS E HIJOS

CHIAPAS # 49
COL. ROMA C.P. 06700
DEL. CUAUHTÉMOC, CIUDAD DE MÉXICO
TEL: (0155) 5 564 58 78 / 55 84 49 12
E-MAIL: hdez_teo@yahoo.com

RIDSÁ

RAFAEL BUELNA #1
COL. TEZOZOMOC C.P. 02459
DEL. AZCAPOTZALCO, CIUDAD DE MÉXICO
TEL: (0155) 55 83 5255 / 26 26 16 52
E-MAIL: a.quezada@ridsamexico.com

**HERRAMIENTAS ELÉCTRICAS
E INDUSTRIALES**

EJIDO MANZANA 28 LOTE 21-A
COL. SAN FRANCISCO TLALTENCO C.P. 13400
CIUDAD DE MÉXICO
TEL: (0155)25 94 42 56 / 63 65 07 14
E-MAIL: htaselect_einds@hotmail.com

DURANGO**REFACCIONARIA FORESTAL GUADIANA**

PROL. BLVD. DOLORES DEL RIO # 210
COL. AZCAPOTZALCO C.P. 34160
DURANGO, DURANGO
TEL: (01618) 813 4 750
E-MAIL: refaccionariaforestalguadiana@hotmail.com

LAGACERO DE DURANGO

AV. FERROCARRIL # 700
COL. FRAY DIEGO DE LA CADENA C.P. 34216
DURANGO, DURANGO
TEL: (01618) 818 10 00 / 818 99 91
E-MAIL: serviciodgo@lagacero.com

HERRAMIENTAS Y ABRASIVOS DURANGO

AV. 20 DE NOVIEMBRE # 2004 OTE.
COL. CENTRO C.P. 34000
DURANGO, DURANGO
TEL: (01618) 818 80 77 / 455 36 56
E-MAIL: hyadurango@hotmail.com

ESTADO DE MÉXICO**TOLUCA****SERVICIOS ESPECIALIZADOS DE TOLUCA**

VIALIDAD ALFREDO DEL MAZO # 70-C
COL. ZONA INDUSTRIAL C.P. 50070
TOLUCA, EDO. DE MÉXICO
TEL: (01722) 167 11 97
E-MAIL: ernesto_bermudez59@hotmail.com

SECURITYSTORE

ADOLFO LÓPEZ MATEOS # 1513
COL. ZONA INDUSTRIAL C.P. 50100
TOLUCA, EDO. DE MÉXICO
TEL: (01722) 167 61 18
E-MAIL: securitystoretoluca@hotmail.com

VALLE DE BRAVO

GRUPO FERRETERO FLORES
AV. FLORES # 501
COL. CENTRO C.P. 51200
VALLE DE BRAVO, EDO. DE MÉXICO
TEL: (01726) 262 22 27
E-MAIL: compras.ferreteria@grupoflores.com

NAUCALPAN

CENTRO DE SERVICIO AVILA NAUCALPAN
AV. 16 DE SEPTIEMBRE # 260
COL. FRACC. INDUSTRIAL ALCE BLANCO
C.P. 53370, NAUCALPAN, EDO. DE MÉXICO
TEL: (0155) 53 58 43 64 / 44 45 65 15
E-MAIL: makita.naucalpan@prodigy.net.mx

PRYFAMINC INTERNACIONAL S.A. DE C.V.

TLATELOLCO # 18
COL. LOMA COLORADA C.P. 53420
NAUCALPAN, EDO. DE MÉXICO
TEL: (01 55) 53 01 11 25 / 53 01 46 70
E-MAIL: pryfaminc@live.com

TLALNEPANTLA

HERRAMIENTAS AMBAR
AV. TOLTECAS # 275
COL. LA ROMANA C.P. 54030
TLALNEPANTLA, EDO. DE MÉXICO
TEL: (0155) 53 90 74 80
E-MAIL: herambar@prodigy.net.mx

HERRAMIENTAS Y REPARACIONES LA LOMA

VIA GUSTAVO BAZ PADRA # 242 ESQ. CHALMA
COL. TLALNEMEX C.P. 54070
TLALNEPANTLA, EDO. DE MÉXICO
TEL: (0155) 53 65 52 20
E-MAIL: herramientaslaloma@yahoo.com.mx

MAPRE

AV. DE LOS MAESTROS # 56
COL. SAN ANDRES ATENCO C.P. 54040
TLALNEPANTLA EDO. DE MÉXICO
TEL: (0155) 65 47 95 43
E-MAIL: mapremakita@yahoo.com.mx

ECATEPEC DE MORELOS

HERRAMIENTAS ECATEPEC
VIA MORELOS # 107 LOCAL 1
COL. HOGARES MEXICANOS C.P. 55040
ECATEPEC DE MORELOS, EDO. DE MÉXICO
TEL: (0155) 57 87 83 29 / 57 87 56 24
E-MAIL: arturoarrellaga@gmail.com

**DISTRIBUIDORA DE HERRAMIENTAS
ELÉCTRICAS**

AV. MORELOS OTE # 43 A
COL. SAN CRISTOBAL C.P. 55000
ECATEPEC, EDO. DE MÉXICO
TEL: (0155) 57 7053 42 / 36 12 04 07
E-MAIL: daniel_grupoferwogt@hotmail.com

NEZAHUALCOYOTL

MARBAL HERRAMIENTAS Y SERVICIO
CABALLO BAYO # 161 A
COL. BENITO JUAREZ C.P. 57000
CIUDAD NEZAHUALCOYOTL, EDO. DE MÉXICO
TEL: (0155) 57 36 84 02 / 51 12 13 64
E-MAIL: marbal@hotmail.com
marbal_1999@yahoo.com.mx

TECAMAC

SERVICIOS Y HERRAMIENTAS DE TECAMAC
MÉXICO PACHUCA KM. 38 S/N
COL. CENTRO C.P. 55740
TECAMAC, ESTADO DE MÉXICO
TEL: (0155) 59 34 42 80 / 65 81 29 94
E-MAIL: jjenzastiga@hotmail.com
jjenzastiga@gmail.com

TEXCOCO

HERRAMIENTAS TEXCOCO
NICOLAS BRAVO S/N
COL. LAS SALINAS C.P. 56152
TEXCOCO, ESTADO DE MÉXICO
TEL: (01595) 931 34 20
E-MAIL: herrinec@hotmail.com

SAN PEDRO CHOLULA

SERVICIO TECNICO MARTINEZ
AV. OCOYOACAC # 16
COL. SAN PEDRO CHOLULA C.P. 52746
SAN PEDRO CHOLULA, ESTADO DE MÉXICO
TEL: (01728) 287 69 05
E-MAIL: max.mtz@live.com

GUANAJUATO**LEON**

GB SERVICIOS Y HERRAMIENTAS
BLVD. ADOLFO LOPEZ MATEOS # 1127 OTE.
COL. COECILLO C.P. 37260
LEON, GUANAJUATO
TEL: (01477) 713 07 72 / 716 50 91 / 514 38 70
E-MAIL: sherdeleongb@hotmail.com

**HERRAMIENTAS Y SERVICIOS DE LEÓN,
S. DE R.L. DE C.V.**

BLVD. ADOLFO LOPEZ M. # 230 OTE.
COL. CENTRO C.P. 37000
LEÓN, GUANAJUATO
TEL: (01477) 714 65 14
E-MAIL: h_s_leon@hotmail.com

ABASTECEDORA LEAL S.A DE C.V.

AV. LA MERCED # 1902 ESQUINA FAISAN
COL. SANTA RITA C.P. 37450
LEÓN, GUANAJUATO
TEL: (01477) 715 16 31 / 770 68 00 / 770 69 27
E-MAIL: leon@abasleal.com

IRAPUATO**LARD. EQUIPOS MECANICOS S. A. DE C. V.**

AV. 1 DE MAYO # 482
COL. CENTRO C.P. 36500
IRAPUATO, GUANAJUATO
TEL: (01462) 626 79 22 / 660 24 57
E-MAIL: lard_equipos@hotmail.com

**HEDELBA HERRAMIENTAS Y SERVICIOS
INDUSTRIALES**

INDEPENDENCIA # 1327
COL. LOS PRESIDENTES C.P. 36550
IRAPUATO, GUANAJUATO
TEL: (01462) 626 23 48
E-MAIL: direccioncomercial.com.mx

CELAYA**HERRAMIENTAS MANOS CREADORAS**

AV. 2 DE ABRIL # 230 LOCAL 204
COL. BARRIO DEL ZAPOTE C.P. 38080
CELAYA, GUANAJUATO
TEL: (01461) 175 48 48
E-MAIL: htasmanoscreadoras@hotmail.com

ROMITA**HERRAMIENTAS Y MANTENIMIENTO OBREGÓN**

ALVARO OBREGÓN # 44
COL. CENTRO C.P. 36200
ROMITA, GUANAJUATO
TEL: (01432) 745 32 84
E-MAIL: manttoyh.obregon@yahoo.com

SAN MIGUEL DE ALLENDE**GRUPO FERRETERO DON PEDRO
S. DE R.L. DE C.V.**

BOULEVARD DE LA CONSPIRACIÓN # 61
COL. INFONAVIT DE LA LUZ, C.P. 37746
SAN MIGUEL DE ALLENDE, GUANAJUATO
TEL: (01415) 120 43 53
E-MAIL: servicio@grupodonpedro.com



CENTROS DE SERVICIO AUTORIZADO MAKITA



COMERCIALIZADORA INDUSTRIAL

LANDETA SA DE CV

CARRETERA SAN MIGUEL DE ALLENDE
A QRO. KM. 2.5
COL. SAN JUAN LANDETA C.P. 37880
SAN MIGUEL DE ALLENDE, GUANAJUATO
TEL: (01415) 109 03 67
E-MAIL: coinlandeta@gmail.com

GUERRERO

ACAPULCO

TOOLS

BLVD. DE LAS NACIONES # 401 LOCAL 6
COL. GRANJAS DEL MARQUEZ C.P. 39890
ACAPULCO, GUERRERO
TEL: (01744) 254 54 91 / 254 00 25 / 466 09 12
E-MAIL: ventas@toolsferreteria.com

ZIHUATANEJO DE AZUETA

FERRETERIA SAN JERÓNIMO

AV. PASEO DE ZIHUATANEJO OTE # 2
COL. ZONA INDUSTRIAL C.P. 40880
ZIHUATANEJO DE AZUETA, GUERRERO
TEL: (01755) 554 07 38 / 554 07 39
E-MAIL: jpablo.avila@hotmail.com

CHILPANCINGO

COMERCIALIZADORA RAYMA

CALLE 17 DE FEBRERO # 24
COL. BENITO JUÁREZ C.P. 39010
CHILPANCINGO DE LOS BRAVO, GUERRERO
TEL: (01747) 471 79 76
E-MAIL: comercializadorarayma@hotmail.com

OMOTEPEC

FERRE ELECTRICA DEL CARMEN

5 DE MAYO # 7-B
COL. BARRIO DEL CARMEN C.P. 41700
OMOTEPEC, GUERRERO
TEL: (01741) 412 01 65
E-MAIL: ferre_elec_elcarmen@hotmail.com

HIDALGO

PACHUCA

SERVIREP HERRAMIENTAS S.A. DE C.V.

BLVD. MINEROS # 700
COL. VENUSTIANO CARRANZA C.P. 42030
PACHUCA HIDALGO
TEL: (01771) 719 24 94 / 246 42 84
E-MAIL: servicerterpachuca@outlook.com

TULANCINGO

HERRAMIENTAS ELÉCTRICAS BADHER

LIBERTAD ORIENTE # 301-7
CASI ESQ. MANUEL M. SOTO
COL. CENTRO C.P. 43600
TULANCINGO, HIDALGO
TEL: (01775) 755 18 85
E-MAIL: badher86@hotmail.com

TULA DE ALLENDE

DISTRIBUIDOR DE HERRAMIENTAS INDUSTRIALES M&M

CARRETERA ESTATAL TULA ACTOPAN # 7
COL. EL CIELITO C.P. 42800
TULA DE ALLENDE, HIDALGO
TEL: (01773) 118 02 07
NEXTTEL: (01773) 159 0125 ID 62*10*42366
E-MAIL: distribuidormakitadetula@hotmail.com

JALISCO

GUADALAJARA

MULTIHERRAMIENTAS S.A. DE C.V.

AV. LA PAZ # 343,
COL. MODERNA, C.P. 44190
GUADALAJARA, JALISCO
TEL: (01333) 38 26 69 76 / 38 26 57 74 / 38 26 91 72
E-MAIL: contacto@multiherramientas.mx

GRUPO CONTINENTE INTERNACIONAL

CALZ. INDEPENDENCIA SUR # 343
COL. ANALCO C.P. 44100
GUADALAJARA, JALISCO
TEL: (01333) 38 83 10 30 EXT. 430
E-MAIL: makita_gdl@gcinter.com / ventas@gcinter.com

RIDS

CALZADA LÁZARO CARDENAS # 1723
COL. DEL SUR C.P. 44920
GUADALAJARA JALISCO
TEL: (01333) 813 81 30 / 587 25 50 / 150 63 00
E-MAIL: servicio1@ridsamexico.com

ZAPOCAN

REIKER SUC. PATRIA

AV. PATRIA # 40-E CASI ESQ. CON AV. VALLARTA
COL. JARDINES VALLARTA C.P. 45027
ZAPOCAN, JALISCO
TEL: (01-333) 629-37-40
E-MAIL: ventas-pat@reiker.mx

REIKER SUC. GUADALUPE

PROL. AV. GUADALUPE #5763 LT. 7
COL. GLORIAS DEL COLLI C.P. 45010
ZAPOCAN, JALISCO
TEL: (0133) 20 16 78 84
E-MAIL: ventas-gpe@reiker.mx

OCOTLÁN

HERRAMIENTAS Y SERVICIOS

MIRANDA S.A. DE C.V.

AV. 20 DE NOVIEMBRE # 156
COL. MARCOS CASTELLANOS C.P. 47870
OCOTLÁN, JALISCO
TEL: (01392) 923 23 00 / 3719 01 26
E-MAIL: hysosa@hotmail.com

TEQUILA

GRUPO FERRETERO FHEGARSA

CARRETERA INTERNACIONAL # 703-A
COL. EL MALUAZTE C.P. 46400
TEQUILA, JALISCO
TEL: (01374) 742 73 34 / 742 73 51
E-MAIL: cedis@fhegarsa.com.mx
anguelo@hotmail.com

PUERTO VALLARTA

FERRE GRUPO UNIÓN

CARRETERA A TEPIC # 94 LOCAL B
CRUCERO DE MEZACLES
ENTRADA A PUERTO VALLARTA
COL. CENTRO C.P. 63738
PUERTO VALLARTA, JALISCO
TEL: (01329) 29 66 152
NEXTTEL: (01322) 145 64 32 ID: 62*325091*4
E-MAIL: csmezcales@live.com.mx

DISTRIBUIDORA DE HERRAMIENTAS DE LA BAHIA

SUCURSAL CENTRO

SAN SALVADOR # 525
COL. 5 DE DICIEMBRE C.P. 48350
PUERTO VALLARTA, JALISCO
TEL: (01322) 223 08 92
f.centro@distribuidoradeherramientasdelabahia.com

DISTRIBUIDORA DE HERRAMIENTAS DE LA BAHIA SU-

CURSAL AEROPUERTO

CARRETERA A TEPIC # 4760-A
COL. GUADALUPE VICTORIA, C.P. 48317
PUERTO VALLARTA, JALISCO
TEL/FAX: (01322) 221 21 00
f.aeropuerto@distribuidoradeherramientasdelabahia.com

MICHOACÁN

MORELIA

ACEROS Y HERRAJES S.A. DE C.V.

AV. MORELOS NORTE # 1861
COL. SANTIAGUITO C. P. 58120
MORELIA, MICHOACÁN
TEL: (01443) 313 13 13 con 10 Líneas
E-MAIL: ventas@ahsa.com.mx

ACEROS Y HERRAJES S.A. DE C.V.

AV. SOLIDARIDAD # 737
COL. VENTURA PUENTE ORIENTE C.P. 58020
MORELIA, MICHOACÁN
TEL: (01443) 317 72 64
E-MAIL: ventas@ahsa.com.mx

CD. HIDALGO

HERRAMIENTAS MARTÍNEZ

FELIPE ANGELES # 31
COL. LAZARO CARDENAS C. P. 61150
CD HIDALGO, MICHOACÁN
TEL: (01-786) 154 42 13
E-MAIL: martinezherramientas@hotmail.com

URUAPAN

HERRAMIENTAS COVARRUBIAS

PASEO LAZARO CARDENAS # 1049
COL. MAGDALENA C.P. 60080
URUAPAN, MICHOACÁN
TEL: (01452) 524 70 24 / 524 65 01
FAX: (01452) 148 02 62
E-MAIL: makitaurapan.bryan@gmail.com

JE FERRETERIAS

CALZADA BENITO JUÁREZ # 173
COL. SAN JUAN QUEMADO C.P. 60030
URUAPAN, MICHOACÁN
TEL: (01452) 519 13 18
E-MAIL: ferreteriasjeczalada@hotmail.com

MULTISERVICIOS

FRANCISCO VILLA # 31
COL. MORELOS C.P. 60050
URUAPAN, MICHOACÁN
TEL: (01-452) 524 73 36
E-MAIL: multiserviciosje@hotmail.com

HERRAMIENTAS Y SERVICIOS R.L.

CALZADA LA FUENTE # 225
COL. EL COLORÍN C.P. 60130
URUAPAN, MICHOACÁN
TEL: (01-452) 148 31 75
E-MAIL: luisgarciafatura@gmail.com

ZACAPU

FERRETERA CENTRAL DE ZACAPU

MADERO NORTE # 157
COL. CENTRO C.P. 58600
ZACAPU, MICHOACÁN
TEL: (01436) 363 03 10 FAX: (01436) 363 21 25
E-MAIL: ferrecen1@prodigy.net.mx

LÁZARO CÁRDENAS

COPROSER

AV. JOSÉ MARÍA MORELOS # 24
COL. ZONA INDUSTRIAL C.P. 60950
LAZARO CARDENAS, MICHOACÁN
TEL: (01753) 532 25 75 FAX: (01753) 532 09 78
E-MAIL: alexorozcoa@yahoo.com

ZAMORA

HSF (HERRAMIENTAS Y SERVICIOS FORESTALES)

JUÁREZ # 150 A
COL. EL CALVARIO C.P. 59600
ZAMORA, MICHOACÁN
TEL: (01351) 517 84 20
E-MAIL: hysforza@yahoo.com

MORELOS

CUERNAVACA

MECÁNICA FERRETERA Y DOMÉSTICA

MARIANO MATAMOROS # 44
COL. CENTRO C.P. 62000
CUERNAVACA, MORELOS
TEL: (01777) 243 75 54 / 314 58 98
E-MAIL: mecanicafferteradomestica@hotmail.com
ferreteradomestica@gmail.com

GENERA EN HERRAMIENTAS Y SERVICIO

MARIANO MATAMOROS # 77
COL. CENTRO C.P. 62000
CUERNAVACA, MORELOS
Tel: (01777) 312-18-55
E-MAIL: ghsmorelos@hotmail.com

**TEMIXCO
RELLYR**

AV. EMILIANO ZAPATA # 161 L 1 Y 2
COL. CENTRO C.P.06580
TEMIXCO, MORELOS
TEL: (01777) 325 01 74
E-MAIL: rellyrtemixco@hotmail.com

**TLALQUITENANGO
MAQUINARIA TLAHUICA**

AV. MORELOS # 60
COL. CENTRO C.P. 62980
TLALQUITENANGO, MORELOS
TEL: (01734) 342 38 16 / 342 13 50
E-MAIL: ventas_maquinariatlahuica@hotmail.com

NAYARIT
ACE HOME CENTER

BLVD. TEPIC-XALISCO # 438
COL. FRESNOS C.P. 63190
TEPIC, NAYARIT
TEL: (01311) 214 22 10 / 214 57 97
FAX: (01311) 214 57 99
E-MAIL: ferrehogar_autoservicio@hotmail.com

**DISTRIBUIDORA DE HERRAMIENTAS DE LA BAHIA
SUCURSAL MEZCALES**

CARRETERA FEDERAL LIBRE TEPIC-PUERTO VALLARTA
#290 B NORTE C.P. 63738
COL. MEZCALES, BAHIA DE BANDERA, NAYARIT
TEL/FAX: (01329) 296 5743
f.mezcales@distribuidoradeherramientasdelabahia.com

**DISTRIBUIDORA DE HERRAMIENTAS DE LA BAHIA
SUCURSAL BUCERIAS**

HEROE DE NACOZARI #762 BUCERIAS C.P. 63732
BAHIA DE BANDERAS, NAYARIT
TEL: (01329) 298 6474
f.bucerias@distribuidoradeherramientasdelabahia.com

NUEVO LEÓN
MONTERREY
ABASTECEDORA LEAL

DR. COSS # 3330 NORTE
ENTRE DAVID A. COSIO Y RAFAEL DE LA PEÑA
COL. DEL NORTE C.P. 64500
MONTERREY, NUEVO LEÓN
TEL: (01818) 351 10 11 / 351 10 91 / 351 20 30
E-MAIL: abasleal@abasleal.com.mx

AUTOGENA Y ELÉCTRICA DEL NORTE

AV. FCO. I MADERO PTE. # 1148
COL. CENTRO C.P. 64000
MONTERREY, NUEVO LEÓN
TEL: (0181) 375 13 04 / 372 13 21
FAX: (0181) 372 88 51
E-MAIL: contacto@autogenayelectrica.com

**JN CENTRO DE SOLDADORAS
Y MANTENIMIENTO INDUSTRIAL**

AV. CHAPULTEPEC # 2239 OTE.
COL. FRACC. BUENOS AIRES C.P. 64800
MONTERREY, NUEVO LEÓN
TEL:(0181) 47 77 57 52
E-MAIL: alfonso_oz@yahoo.com.mx

CENTRO DE HERRAMIENTAS Y SERVICIO

EDISON # 907 NORTE
COL. CENTRO C.P. 64000
MONTERREY, NUEVO LEÓN
TEL: (0181) 348 17 75 / 346 42 00
FAX: (0181) 478 72 69
E-MAIL: cen_her@prodigy.net.mx

HIGHCOLOR SA DE CV

BERNARDO REYES # 4217 NORTE
COL. NIÑO ARTILLERO C.P.64280
MONTERREY NUEVO LEON
TEL: (01818) 771 11 12
E-MAIL: ernesto.rodriguez@alcon.com.mx

HERRAMIENTAS SERVIMADERO

AV. FELIZ GÓMEZ #1328 NORTE
COL. TERMINAL C.P.642530
MONTERREY, NUEVO LEON
TEL: (01818) 374 67 96 / 374 51 36
E-MAIL: toncarr@gmail.com

FERRETERIAS PRINEL

AV. MADERO # 675 PTE.
COL. CENTRO C.P. 64000
MONTERREY, NUEVO LEÓN
TEL. (0181) 372 64 40 / 372 64 20 / 375 23 20
E-MAIL: sucmd@fprinel.com

GUADALUPE
AIR WELDING

PROL. RUIZ CORTINEZ # 801 OTE
COL. VILLA DE SAN MIGUEL C.P. 67110
GUADALUPE, NUEVO LEÓN
TEL: (0181) 364 51 81 / 364 41 46
E-MAIL: ventas@airwelding.mx

SAN PEDRO GARZA GARCIA
FERRETERIAS PRINEL

AV. VASCONCELOS PTE. # 104
COL. TAMPIQUITO C.P. 66240
SAN PEDRO GARZA GARCIA, NUEVO LEÓN
TEL. (01818) 338 64 30 / 372 64 20
E-MAIL: contabilidad@fprinel.com

OAXACA
OAXACA
IMPLEMENTOS FORESTALES DEL SURESTE

VALERIO TRUJANO # 707
COL. CENTRO C.P.68000
OAXACA DE JUÁREZ, OAXACA
TEL: (01951) 514 85 08 / 514 85 07 / 516 12 60
FAX: (01951) 514 85 09
E-MAIL: ifssa@terra.com.mx / ifssa@prodigy.net.mx

CORPORATIVO EMPRESARIAL LA ASUNCIÓN

CARRETERA INTERNACIONAL # 1814
COL. SANTA LUCIA DEL CAMINO, C.P. 71228
SANTA CRUZ XOXOCOTLAN, OAXACA
TEL: (01951) 515 94 45
E-MAIL: servicio@lobus.com.mx

SANTA CRUZ XOXOCOTLAN
MAKISERV OAXACA

SIMBOLOS PATRIOS # 101
COL. ELISEO JIMÉNEZ RUIZ, C.P. 71230
SANTA CRUZ XOXOCOTLAN, OAXACA
TEL: (01951) 516 45 94
E-MAIL: makiserv_oax@live.com.mx

MIAHUATLÁN
MOTOSIERRAS Y FERRETERIA PINACHO

BASILIO ROJAS # 304
COL. CENTRO C.P. 70800
MIAHUATLÁN, OAXACA
TEL: (01951) 572 13 38
E-MAIL: ferre_pinacho@hotmail.com

HEROICA CIUDAD DE TLAXIACO
FERRESTEEL

MORELOS # 304
COL. CENTRO C.P. 69800
HEROICA CIUDAD DE TLAXIACO, OAXACA
TEL: (01953) 552 02 98
E-MAIL: rferresteel@gmail.com

PUERTO ESCONDIDO
DELTA INDUSTRIAL

3RA. PONIENTE, ENTRE 5TA. Y 6TA. NORTE S/M
COL. SECTOR JUAREZ C.P. 71984
PUERTO ESCONDIDO, OAXACA
TEL: (01954) 104 22 93
E-MAIL: delta_refacciones@hotmail.com

SALINA CRUZ
HERRAMIENTAS ITSMO

CAMINO VIEJO A LA VENTOSA # 4
COL. HILDALGO ORIENTE C.P. 70610
SALINA CRUZ, OAXACA
TEL: (01971) 725 15 52
E-MAIL: makitaherramientas@gmail.com

TUXTEPEC
CENTRO DE SERVICIO LOS ANGELES

AV. 5 DE MAYO # 1613
COL. CENTRO C.P. 68310
TUXTEPEC, OAXACA
TEL: (01287) 871 06 73
E-MAIL: losangeles.fac@gmail.com

PUEBLA
PUEBLA
FERRE PAT DE PUEBLA

8 PONIENTE # 909 ENTRE LA 9 Y 11 NORTE
COL. CENTRO C.P. 72000
PUEBLA, PUEBLA
TEL: (01222) 246 50 34 / 242 41 42
E-MAIL: eduardovasquez@ferrepat.com

CREAR HOGAR S.A. DE C.V.

BLVD. NORTE Y BLVD. HERMANOS SERDÁN
COL. AMOR C.P. 72140
PUEBLA, PUEBLA
TEL:(01222) 248 37 59 / 249 39 04 EXT TALLER 106
FAX:(01222) 248 60 46
E-MAIL: creahogar@prodigy.net.mx

TODOSERVICIO Y HERRAMIENTAS

30 PONIENTE # 2540 LOCAL 2
COL. AURORA C.P. 72070
PUEBLA, PUEBLA
TEL: (01222) 298 25 06 / 298 25 07
E-MAIL: makitapuebla@prodigy.net.mx

IMPLEMENTOS FORESTALES DEL SURESTE

17 PONIENTE # 2114
COL. RIVERAS DE SANTIAGO C.P.72480
PUEBLA, PUEBLA
TEL: (01222) 243 07 51
E-MAIL: ifsa_puebla@hotmail.com

GENERAL EN HERRAMIENTAS Y SERVICIO

17 NTE. ESQ. 4 PTE.
COL. CENTRO
PUEBLA, PUEBLA C.P. 72000
TEL: (222) 2 46 50 67 / 246 37 26
E-MAIL: ghsblackanddeckerpuebla@telmexmail.com

CHIPILO
AVM TOOLS

AV. 5 DE MAYO # 610 COL. JAVIER MINA
CHIPILO, PUEBLA
TEL: (01222) 283 10 78
E-MAIL: avmtools410@gmail.com.mx

TEHUACÁN
EL FERRETERO

AV. INDEPENDENCIA OTE. # 502-A
COL. CENTRO C.P. 75700
TEHUACÁN, PUEBLA
TEL: (01238) 383 16 77 / 371 77 81
FAX: (01238) 383 03 33
E-MAIL: ferretero13@yahoo.com.mx

FERRE PAT

CALLE 3 SUR # 535 ESQ. PEDRO DEL VALLE
COL. DEL EMPLEADO C.P 75700
TEHUACÁN, PUEBLA
TEL: (01238) 382 62 44 / 384 67 90
E-MAIL: roberto.martinez@ferrepat.com



CENTROS DE SERVICIO AUTORIZADO MAKITA

SAN JOSÉ ALCHICHICA

DITORSA
CARRETERA FEDERAL MÉXICO VERACRUZ S/N
COL. CENTRO C.P. 73996 SAN JOSÉ ALCHICHICA
MUNICIPIO DE TEPEYAHUALCO, PUEBLA
TEL: (01282) 832 00 01 / 832 03 27
E-MAIL: ditorsaalchichica@hotmail.com

QUERÉTARO

QUERÉTARO HERRAMIENTAS Y REPARACIONES INDUSTRIALES

CORREGIDORA # 977
COL. VILLAS DEL PARQUE C.P. 76169
QUERÉTARO, QUERÉTARO
TEL: (01442) 220 86 96 / 220 77 74 / 002 79 32
E-MAIL: hyrisa@prodigy.net.mx

HERRAMIENTAS REFACCIONES Y ACCESORIOS

CALLE GONZALO RIO ARRONTE # 9
COL. VILLAS DEL SUR C.P. 76040
QUERÉTARO, QUERÉTARO
TEL: (01442) 295 95 92 / 388 80 69
E-MAIL: herreyace@gmail.com

HERRAMIENTAS Y REPARACIONES ALVAREZ

AVENIDA RIO AYUTLA # 58
COL. LA PIEDAD C.P. 76150
QUERÉTARO, QUERÉTARO
TEL: (01-442) 242 92 16
E-MAIL: herramientasyreparacionesalvarez@hotmail.com

SAN JUAN DEL RIO HERRAMIENTAS Y SERVICIOS INDUSTRIALES

AV. LOMAS DE SAN JUAN # 102
COL. LOMAS DE SAN JUAN C.P. 76806
SAN JUAN DEL RIO, QUERÉTARO
TEL: (01427) 274 45 96
E-MAIL: herramientas.123@hotmail.com

QUINTANA ROO

CANCÚN REALSA CANCÚN

AV. TORCASITA Y JOSÉ LUIS PORTILLO,
SM 69 MZ.1 LOTES 28 AL 30 C.P. 77510
CANCÚN, QUINTANA ROO
TEL: (01998) 887 52 99 / 884 72 27 / 887 33 86
E-MAIL: administracion@gruporealsa.com

MAQUINARIA LIGERA PARA LA CONSTRUCCIÓN (CANCÚN)

AV. 127 MZ. #104 LT 16 ESQ. CALLE 20
COL. REGION CIEN C.P. 77518
CANCÚN, QUINTANA ROO
TEL: (01998) 146 05 02
maquinarialigerap.construccioncancun@hotmail.com

PLAYA DEL CARMEN MAQUINARIA LIGERA PARA LA CONSTRUCCIÓN (PLAYA DEL CARMEN)

AV. JUÁREZ MZ 219 LT 4 ENTRE 55 Y 60
COL. EJIDO C.P. 77710
PLAYA DEL CARMEN, QUINTANA ROO
TEL: (01984) 110 51 14
maquinarialigerap.construccionplaya@hotmail.com

MATERIALES EL UNICORNIO

AV. 115 NORTE MZ. 182 LT. 7POR CALLE 28
COL. EJIDO C.P. 77710
PLAYA DEL CARMEN, QUINTANA ROO
TEL: (01984) 803 95 96 / 803 95 75
E-MAIL: ventas@materialesunicornio.com.mx

CONSTRU HERRAMIENTAS DE LA RIVERA

AV. JUÁREZ MZ.211 LT.12 ENTRE 60 Y 70
COL. EJIDO C.P.77710
PLAYA DEL CARMEN, QUINTANA ROO
TEL: (01984) 206 23 18 / 733 33 50
E-MAIL: constru_htasplayadelcarmen@hotmail.com

CHETUMAL

GRUPO FERRETERO CONTINENTAL SA DE CV

VENUSTIANO CARRANZA # 242
ESQ. INDEPENDENCIA
COL. VENUSTIANO CARRANZA C.P. 77012
CHETUMAL, QUINTANAROO
TEL: (01983) 832 13 84 / 832 12 95
E-MAIL: servicio@gfcontinental.com

SAN LUIS POTOSÍ

ELEC NEUMATIC SA DE CV

AV. JOAQUÍN ANTONIO PEÑALOSA # 316
COL. EL PASEO C.P. 78320
SAN LUIS POTOSÍ, SAN LUIS POTOSÍ
TEL: (01444) 816 31 46 / 818 02 94
E-MAIL: mostrador@grupohica.com.mx
serviciomakita@grupohica.com.mx

CIFERIN

5 DE MAYO # 2375
COL. FRACC. VILLA RICA C.P. 78360
SAN LUIS POTOSÍ, SAN LUIS POTOSÍ
TEL: 01 (444) 820 73 72 / 820 29 08 / 129 42 21
E-MAIL: joel.hb@hotmail.com

SINALOA

CULIACÁN SERVIMAK HERRAMIENTAS

AV. GUADALUPE VICTORIA # 888-B SUR
COL. JORGE ALMADA C.P. 80200
CULIACÁN, SINALOA
TEL y FAX: (01667) 455 36 24
E-MAIL: servimakherramientas@outlook.com

SERVIMAK HERRAMIENTAS

BLVD. EMILIANO ZAPATA # 2590
COL. EL PALMITO C.P. 80110
CULIACÁN, SINALOA
TEL: (01667) 455 11 65
E-MAIL: servimakherramientas@outlook.com

LOS MOCHIS

DOIT CENTER (FIERRO Y LAMINAS DE LOS MOCHIS)

JUÁREZ ESQ. ZARAGOZA
COL. CENTRO C.P. 81200
LOS MOCHIS, SINALOA
TEL: (01668) 812 02 81 / 112 02 81 / 812 52 06
E-MAIL: ventas@doitcenter.com.mx

BABATSA

AV. INDEPENDENCIA # 1338
COL. FRACC JARDINES DEL VALLE C.P. 81245
LOS MOCHIS, SINALOA
TEL: (01668) 815 20 80
E-MAIL: gerencia.independencia@babatsa.com.mx

MAZATLÁN

DAMASO CHAPAS Y HERRAJES

RAFAEL BUELNA #330 INT. 1
HACIENDA LAS CRUCES, C.P. 82126
MAZATLÁN, SINALOA
TEL: (01669) 112 10 48 / 112 10 49
E-MAIL: ventas@damaso.com.mx

SERHSI

RAFAEL BUELNA # 928 INT. 1
COL. SANCHEZ CELIS C.P. 82120
MAZATLÁN, SINALOA
TEL: (01669) 112 12 75
E-MAIL: ventas@serhsi.com
roxana.crespo@serhsi.com

RENTAMEX

FRANCISCO LABASTIDA OCHOA # 15
COL. MAGISTERIO C.P. 81470
MAZATLÁN, SINALOA
TEL: (01673) 732 41 30
E-MAIL: elremateguamuchil1@outlook.es

GUASAVE

FERRETO DOB

BLVD. 16 DE SEPTIEMBRE S/N ESQ. GABRIEL
MEDINA MTZ Y SÁNCHEZ TABOADA
COL. CENTRO C.P. 81000
GUASAVE, SINALOA
TEL: (01687) 131 18 25
E-MAIL: ferretodob@gmail.com

SONORA

HERMOSILLO

SOLDADURA EQUIPO Y CONSTRUCCIÓN S.A.

NAYARIT # 217 ENTRE REFORMA
Y GPE. VICTORIA
COL. SAN BENITO C.P. 83190
HERMOSILLO, SONORA
TEL: (01662) 210 25 00 FAX: (01662) 210 25 50
E-MAIL: secsherramientas@prodigy.net.mx

DECSSON WELDING

SUAQUI # 34 COL. PIMENTEL C.P. 83188
HERMOSILLO, SONORA
TEL: (01662) 260 72 68 / 260 64 04
E-MAIL: gabrielgonzalez@decssonwelding.com.mx

HSO HERRAMIENTAS Y SERVICIOS

BLDV. AGUSTÍN DE VIDOSOLA # 300
COL. PEDREGAL DE LA VILLA C.P. 83290
HERMOSILLO, SONORA
TEL: (01662) 250 60 10
E-MAIL: luispadilla@hso.com.mx

SIS Y GASES DE HERMOSILLO

C. AYUNTAMIENTO ESQ. PERIFERICO NORTE #583
COL. CHOYAL C.P. 83130
HERMOSILLO SONORA
TEL: (01662) 313 24 95 / 311 62 02
E-MAIL: servicioclientes@sisygases.com.mx

CIUDAD OBRÉGÓN

SIS Y GASES DE CAJEME

JACINTO LÓPEZ 401 PTE.
COL. FAUSTINO FELIX C.P. 85180
CIUDAD OBRÉGÓN, SONORA
TEL: (01644) 417 68 80 / 417 09 08
E-MAIL: estebanlagarda@hotmail.com

HSO HERRAMIENTAS Y SERVICIOS

DR. NORMAN E BORTAUG # 2605 SUR
COL. MUNICIPIO LIBRE C.P. 85080
CD. OBRÉGÓN, SONORA
TEL: (01644) 417 11 95 TALLER EXT 112
E-MAIL: compras2@hso.com.mx

SAN LUIS RÍO COLORADO

FETASA RÍO COLORADO

AV. NAYARIT Y CALLE 26 #2510
COL. JALISCO C.P. 83447
SAN LUIS RÍO COLORADO, SONORA
TEL: (01653) 534 57 53 / 534 96 97 / 535 62 02
E-MAIL: acofetasa@yahoo.com.mx

PUERTO PEÑASCO

TODO PARA EL CARPINTERO

AV. TECLA DE BUSTAMANTE S/N
ESQ. LEÓN DE LA BARRA
COL. ORIENTE C.P. 83550
PUERTO PEÑASCO, SONORA
TEL: (01638) 383 10 01 / 388 64 66
FAX: (01638) 383 10 01
E-MAIL: todo_para_el_carpintero@prodigy.net.mx

SECSA PEÑASCO

ADOLFO LÓPEZ MATEOS Y JUSTO SIERRA # 219
COL. CENTRO C.P. 83550
PUERTO PEÑASCO, SONORA
Tel: (01638) 388 67 88 / FAX: 388 67 89
E-MAIL: secsapenasco@prodigy.net.mx,
ventaspp@secsatools.com.mx

**NOGALES****SUMA INDUSTRIAL**

CALLE ACRÓPOLIS #185,
COL. JARDINES DE KALITEA, C.P. 84066
NOGALES, SONORA
TEL: (01631) 313 78 99 / 320 02 99 / 314 47 67
E-MAIL: omaldonado@mgdistribuciones.com

IGC ACCESORIOS Y REFACCIONES

AV. DE LOS NOGALES # 277 LOCAL 12
COL. SAN CARLOS, C.P. 84090
NOGALES, SONORA
TEL: (01631) 315 73 13
E-MAIL: ivangalvezchavarria@gmail.com

GUAYMAS**ESINSA SEGURIDAD INDUSTRIAL**

CARRERA INTERNACIONAL # 1037 A
COL. PETROLERA C.P. 85456
GUAYMAS, SONORA
TEL: (01622) 222 97 76 / 222 97 77
E-MAIL: esinsa@hotmail.com

NAVOJOA**SIS Y GASES DE CAJAME**

TALAMANTE # 704 A
COL. CONSTITUCIÓN C.P. 85820
NAVOJOA, SONORA
TEL: (01642) 421 07 04 / 421 11 09
E-MAIL: sisygasesnavojoa@hotmail.com,
rodirgo.felixd@gmail.com

CABORCA**CONSTRUCENTRO DE CABORCA**

OBREGON #. 77 ENTRE A Y B
COL. CENTRO C.P. 85820
CABORCA, SONORA
TEL: (01637) 372 30 40 / 372 44 40 / 372 60 40
E-MAIL: construcentrocaborca@hotmail.com

TABASCO**VILLAHERMOSA****REALSA VILLAHERMOSA**

AV. CONSTITUCIÓN # 516
COL. CENTRO C.P. 86000
VILLAHERMOSA, TABASCO
TEL: (01993) 312 53 17
E-MAIL: ventasv1@gruporealsa.com

MERSOL SURESTE

AV. RUIZ CORTÍNEZ # 2001-B
COL. ATASTA C.P. 86100
VILLAHERMOSA, TABASCO
TEL: (01993) 161 44 79 / 161 48 20
E-MAIL: servicio.tecnico@mersolsureste.com.mx

TAMAULIPAS**REYNOSA****STEEL MART, MERCADO DEL ACERO**

HERON RAMIREZ # 1445
COL. RODRÍGUEZ C.P. 88630
REYNOSA, TAMAULIPAS
TEL: (01899) 909 50 00
E-MAIL: makita@steelmart.com.mx

STEEL MART SUC 3

CARR. A MONTERREY KM 203
COL. BUGAMBILIAS C.P. 88707
REYNOSA, TAMAULIPAS
TEL: (01899) 909 54 00 / 954 70 00
E-MAIL: jose.castillo@steelmart.com.mx

TAMPICO**CF ANCLAJE Y HERRAMIENTAS, S.A. DE C.V.**

CARRERA TAMPICO MANTE # 501-B
COL. FCO. JAVIER MI NA C.P. 89318
TAMPICO, TAMAULIPAS
TEL: (01833) 226 47 82 / 31 51
E-MAIL: cfanclajeyherramientas@gmail.com
cfanclajenorte@prodigy.net.mx

ALTAMIRA**DISTRIBUCIONES T.C.**

CORONEL TRILLO #500-A
COL. INDUSTRIAL GUERRERO C.P. 89603
ALTAMIRA, TAMAULIPAS
TEL: (01833) 264 40 83
E-MAIL: wcardenas.hysa@hotmail.com

CIUDAD MADERO**INGENIEROS Y TECNICOS ASOCIADOS**

NECAXA # 513 NORTE,
COL. FELIPE CARRILLO PUERTO C.P. 89430
CD. MADERO, TAMAULIPAS
TEL: (01 833) 216 82 16 / 221 34 50
E-MAIL: fernandogonzalez@prodigy.net.mx

MATAMOROS**FESOVI SA**

DIAGONAL CUAUHTEMOC #98-B
COL. INDUSTRIAL C.P. 87350
MATAMOROS TAMAULIPAS
TEL: (01868) 812 30 50 / 812 30 30
E-MAIL: carloscasas@diheresa.com

CD MANTE**TUBOS Y TORNILLOS DEL MANTE**

AV. OBREGÓN ORIENTE # 600
COL. CENTRO C.P. 89800
CD. MANTE, TAMAULIPAS
TEL: (01831) 232 46 06 / 232 38 05
E-MAIL: tubytornefdi@mante.com.mx

CD. VICTORIA**FERRETERIA Y SOLDADURAS****VICTORIA S.A. DE C.V.**

AIRE # 2002
COL. FRACC. COMERCIAL 2000 C.P. 87099
CD. VICTORIA, TAMAULIPAS
TEL: (01834) 316 86 11 / 314 18 44
E-MAIL: fesovisa@prodigy.net.mx

NUEVO LAREDO**MADERERA ELIZONDO DE NUEVO LAREDO**

CÉSAR LÓPEZ DE LARA # 2844
COL. JESÚS GARCÍA C.P. 88150
NUEVO LAREDO, TAMAULIPAS
TEL: (01867) 714 20 20
E-MAIL: centrodeservicio@melizondo.mx

TLAXCALA**APIAZCO****SERVICIO RUIZ**

2 DE ABRIL # 508-A
COL. CENTRO C.P. 90300
APIZACO, TLAXCALA
TEL: (01241) 417 22 38
E-MAIL: makitalaxcala@hotmail.com

VERACRUZ**VERACRUZ****FERRETERIA OLMECA**

MANUEL DE JESÚS CLOUTHIER # 8621
COL. LOMA DE TEJERÍA C.P. 91697
VERACRUZ, VERACRUZ
TEL: (01229) 920 87 77
E-MAIL: servicio@ferreteriaolmeca.com

ADS PUERTAS & PORTONES AUTOMATICOS

AV. MIGUEL ALEMÁN # 1995,
COL. CÁNDIDO AGUILAR C.P. 91789,
VERACRUZ, VERACRUZ
TEL: (01229) 100 23 43
E-MAIL: ventas.veracruz@adsver.com.mx
portonesautomaticos@adsver.com.mx

MERCADO DE LA SOLDADURA**DEL SURESTE, S.A. DE C.V.**

HERNAN CORTES # 584 Y 588
COL. CENTRO C.P. 91700
VERACRUZ, VERACRUZ
TEL: (01229) 331 54 44
E-MAIL: gerenciaver@mersolsureste.com.mx

CORDOBA**HERRAMIENTAS Y MOTORES HANA**

AV. 3 # 1318-B
COL. CENTRO C.P. 94500
CORDOBA, VERACRUZ
TEL: (01271) 714 86 46 / 717 82 69
NEXTEL: 62*219867*1
E-MAIL: alexandervalencia61@hotmail.com
tallermakita@hotmail.com

ORIZABA**HERRAMIENTAS Y MOTORES HANA**

NORTE 14 (ENTRE OTE. 7 Y 5)
COL. EMILIANO ZAPATA NORTE C.P. 94320
ORIZABA, VERACRUZ
TEL: (01272) 724 51 38
E-MAIL: alexandervalencia61@hotmail.com

COATZACOALCOS**INTERNACIONAL DEL GOLFO**

MORELOS # 507-B
COL. CENTRO C.P. 96400
COATZACOALCOS, VERACRUZ
TEL: (01921) 212 43 86 / 212 92 57 / 212 55 14
E-MAIL: internacionaldelgolfo@gmail.com

SAN RAFAEL**FECEGO**

DIAZ MIRON # 5
COL. CENTRO C.P. 93620
SAN RAFAEL, VERACRUZ
TEL: (01232) 324 90 60
E-MAIL: auribe.fecego@gmail.com

POZA RICA**FRAZA**

CALLE CONSTITUCIÓN # 507 B
COL. TAJIN C.P. 93330
POZA RICA, VERACRUZ
TEL: (01782) 119 08 37 / 823 92 96 / 160 68 53
E-MAIL: frazapr@hotmail.com

YUCATÁN**MERIDA****REALSA YUCATÁN**

CALLE 63 # 452-E (ENTRE 50 Y 52)
COL. CENTRO C.P. 97000
MERIDA, YUCATÁN
TEL: (01999) 924 01 20 / 924 89 07
E-MAIL: gabrielgonzalez@gruporealsa.com
realsa1@prodigy.net.mx

ZACATECAS**ZACATECAS****METALS & SUPPLIES**

CALZADA UNIVERSIDAD # 202-A
COL. FRACC. PROGRESO C.P. 98066
ZACATECAS, ZACATECAS
TEL: (01492) 998 24 94 / 925 59 69
E-MAIL: l.flores@metals.com.mx
a.luevano@metals.com.mx

FRESNILLO**CENTAURAS MÁQUINAS Y HERRAMIENTAS**

JOYA # 10
COL. LA JOYA C.P. 99030
FRESNILLO, ZACATECAS
TEL: (01493) 878 15 15 / 878 06 90 EXT. 106
E-MAIL: admn_centaurozac@hotmail.com



AVISO DE SEGURIDAD

Instrucciones básicas para su salud y seguridad

Lea siempre el manual de **INSTRUCCIONES** de sus herramientas



Cuidado físico

1. Utilice lentes y zapatos de seguridad, además de guantes y tapones auditivos.
2. Para trabajos con polvo y chispa utilice máscara ó careta.
3. Porte ropa apropiada de trabajo, que no se atore.
4. No opere las herramientas si está cansado.

Postura de trabajo

1. Mantenga los pies firmes para un buen equilibrio.
2. Utilice la herramienta en la posición correcta.
3. No force las herramientas en trabajos no apropiados.



Mantenimiento

1. Almacene las herramientas en un lugar seco y seguro.
2. Revise regularmente el buen funcionamiento de las herramientas y accesorios.
3. Utilice sólo piezas y refacciones originales en caso de reposición.
4. Antes de conectar la herramienta, revise los niveles de voltaje.



Ambiente de trabajo

1. Mantenga el área de trabajo seca y limpia.
2. Mantenga a distancia a niños o personas ajenas.
3. Evite sustancias inflamables o exponer las herramientas eléctricas a la lluvia.
4. Sujete o estabilice los materiales a trabajar.
- 5.- Mantenga el área de trabajo iluminada.



Manejo de las herramientas

1. Seleccione y utilice las herramientas adecuadas para cada tipo de trabajo.
2. No desconecte el cable jalándolo o manejándolo bruscamente.
3. Use apropiadamente los accesorios o aditamentos adicionales.
4. Tenga cuidado de no trabajar o dejar las herramientas cerca de objetos afilados que puedan dañarla.
5. Desconecte las herramientas eléctricas si no están en uso.





Camino Viejo a San Lorenzo Tepaltitlán (José Martí) # 227
Col. Tlacopa C.P. 50010, Toluca, Estado de México

Tels: (722) 385 8800 2373293

www.makita.com.mx