

Model No.DTW190 CORDLESS IMPACT WRENCH

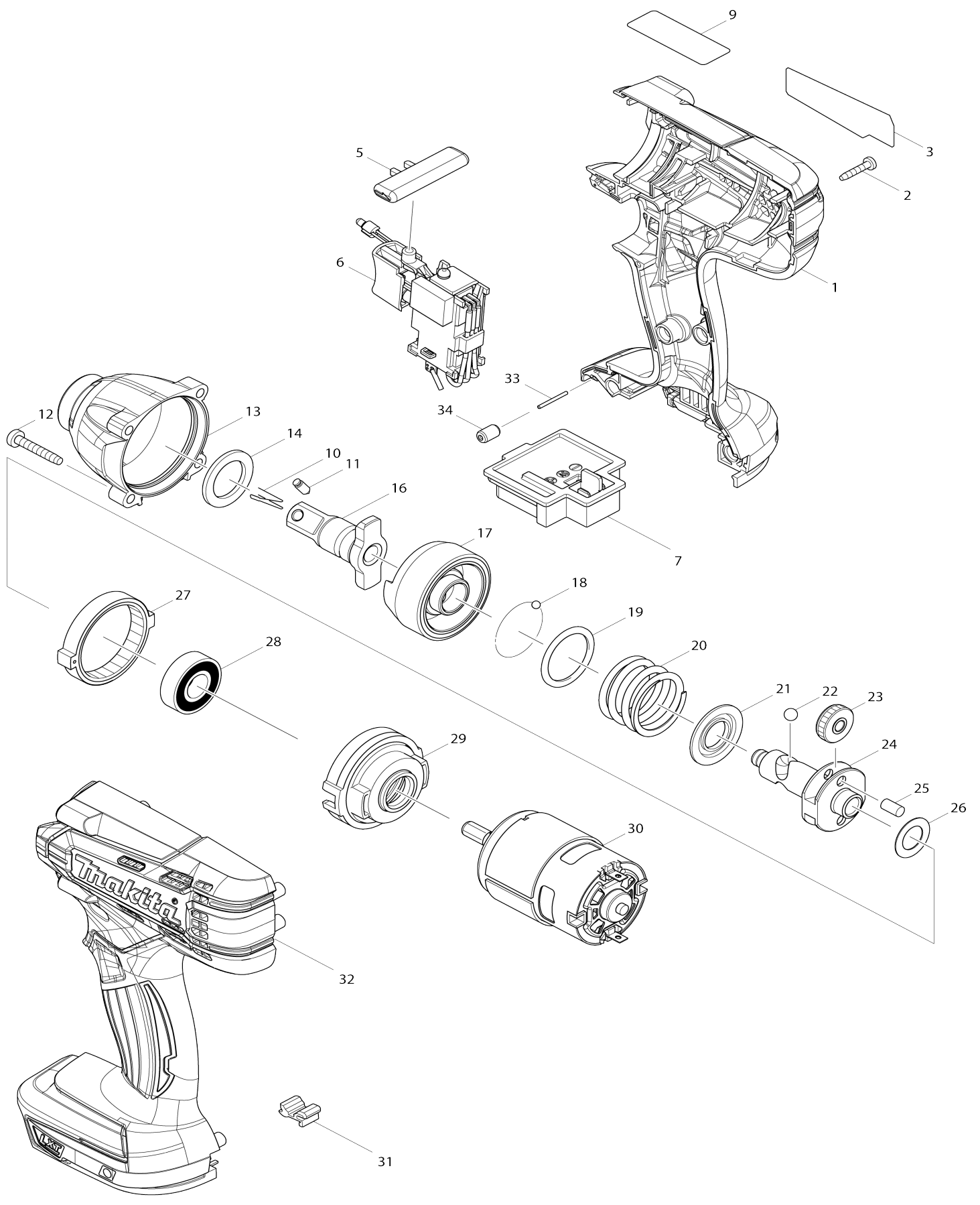

Model No.DTW190 CORDLESS IMPACT WRENCH

Artículo No.	No. de Partes	Descripción	Intercambialidad	Cantidad	Nuevo/Viejo	Nota 1	Nota 2
001	183D73-3	Conjunto del carcasa		1	*		
C10	263005-3	Pasador de goma 6		2	*		
C20	252126-6	Contratuera hexagonal M4-7		2	*		
001		INC. 32			*		
001-1	183D73-3	Conjunto del carcasa	<	1			
C10	263005-3	Pasador de goma 6		2			
C20	252126-6	Contratuera hexagonal M4-7		2			
001-1		INC. 32					
002	266429-2	Tornillo enroscante con cabezal fijador 3X16		8			
003	851W90-2	Placa de características DTW190		1			
005	452399-3	Palanca de cambio f/r		1			
006	632G35-1	Unidad de interruptor		1	*		
006-1	632J82-0	Unidad de interruptor	<	1			
C30	654086-2	Receptáculo 42486-2		2			
C40	654199-9	Receptáculo		2			
007	643852-2	Terminal		1			
010	322045-1	Sujetador de presión		1			
011	323675-1	Pasador 4		1			
012	266374-1	Tornillo enroscante con cabezal fijador 4X25		4			
013	143646-0	Caja del martillo completo		1			
C10	213214-4	Anillo o-ring 16		1	*		
C11	213207-1	Anillo o-ring 16	O	1	*		
C12	213882-3	Anillo o-ring 16	<	1			
014	261151-6	Arandela de nylon 19		1			
016	326694-6	Yunque A		1			
017	326110-8	Martillo		1			
018	216040-0	Bola de acero 3.5		24			
019	267175-0	Arandela plana 24		1			
020	233430-2	Resorte de compresión 24		1			
021	267766-7	Arandela cóncava 14		1			
022	216041-8	Bola de acero 5.6		2			
023	227362-3	Engranaje recto 22		2			
024	326109-3	Husillo		1			
025	256253-1	Pasador 5		2			
026	267212-0	Arandela plana 12		1			
027	227279-0	Engranaje interno 51		1			
028	210107-6	Rodamiento de balines 6001ZZ		1			
029	453056-6	Caja del engranaje interno		1			
030	629195-6	Motor cc		1			
031	424476-1	Cojín		1			
032	183D73-3	Conjunto del carcasa		1	*		
C10	263005-3	Pasador de goma 6		2	*		
C20	252126-6	Contratuera hexagonal M4-7		2	*		
032		INC. 1			*		
032-1	183D73-3	Conjunto del carcasa	<	1			
C10	263005-3	Pasador de goma 6		2			

C20	252126-6	Contratuerca hexagonal M4-7		2			
032-1		INC. 1					
033	268284-8	Pasador 1.5		1			
034	263036-2	Pasador de goma 5		1			
F01	195779-7	Conjunto de ganchos		1			

Por favor declare No. de Partes cuando ordene.

Fecha de Impresión 22/01/2025